

The HV-FxxCL series cameras can be remotely controlled from a PC, etc.  
The control method is described below.

**1. Control specifications**

- |                          |   |
|--------------------------|---|
| (1) Bit rate             | 19200bps  |
| (2) Communication system | Full duplex   |
| (3) Sync system          | Start-stop system   |
| (4) Transmission system  | Bit serial  |
| (5) Used code            | 8-bit binary  |
| (6) Bit composition      | start bit : 1-bit<br>Data bit : 8-bit<br>Parity bit: None<br>Stop bit : 1-bit   |
| (7) Error detection      | 1. SUM check (16-bit)<br>2. Time check (Time between, the respond command and ACK, NAK receiving should be less than 0.5 second.) |
| (8) Error correction     | Request repeat system   |

Note: When the HV-FxxCL series is controlled from a PC, the capacity of the buffer for the transmitted serial data is 128 bytes. When the camera ends the processing of a received command, it releases the buffer area for the command. Though the processing time for a command is normally approx. 20ms, the processing time for a response request command, the auto white balance (AWB) command, the auto shading control (ASC) command, the auto black balance (A. BLACK) command, etc. is in units of second. When setting commands are being transmitted to the camera during the processing time, the receive buffer overflows, resulting in causing malfunction.  
Therefore, be sure to transmit a response request command or a command related to the auto control functions after a response command has been returned from the camera.

## 2. Control sequence

### 2.1 Basic system

The control command and the response command can be transmitted independently. The cameras cannot transmit the control command during receiving response command or response request command.

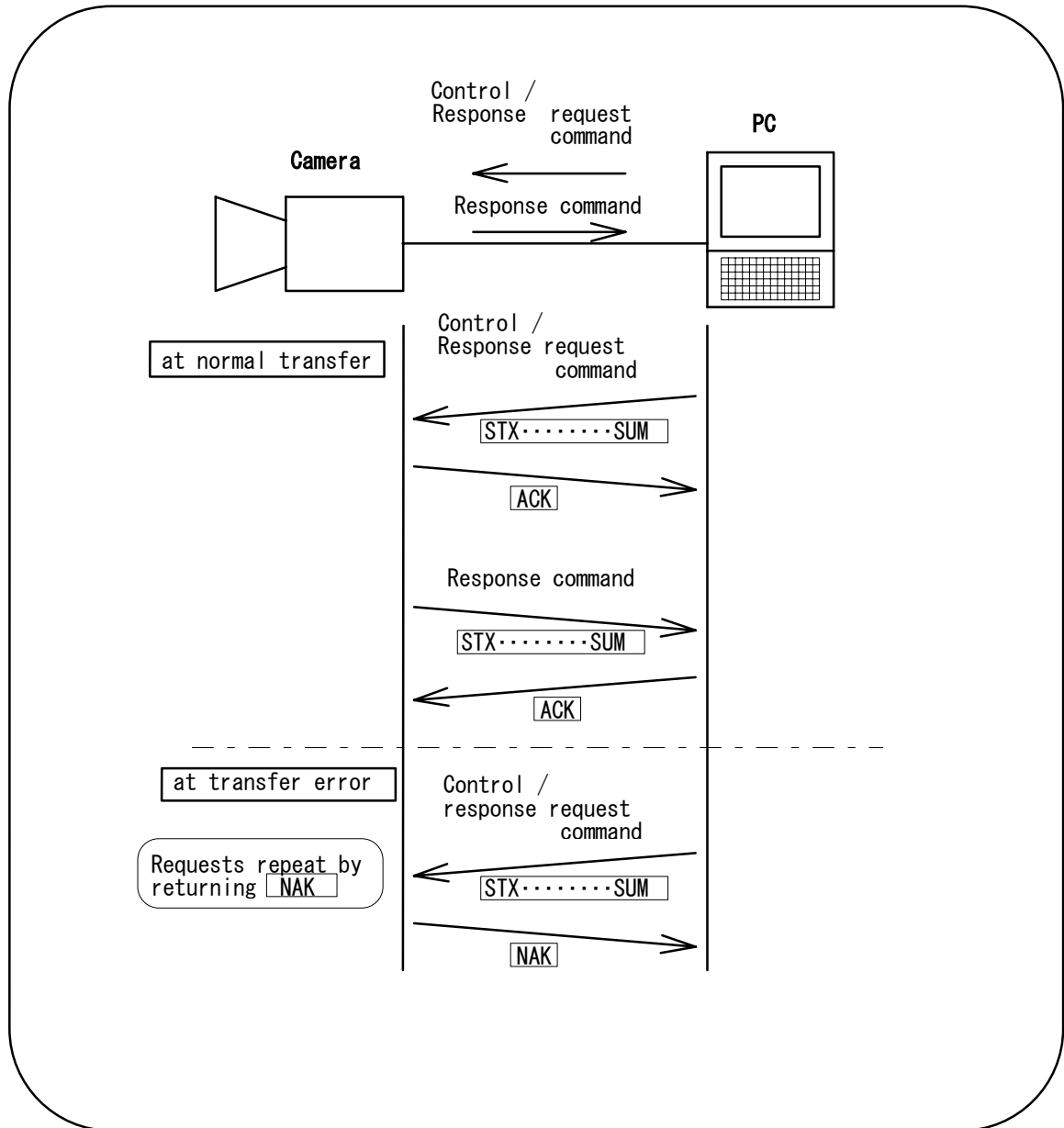

3. Character (1 byte) bit composition

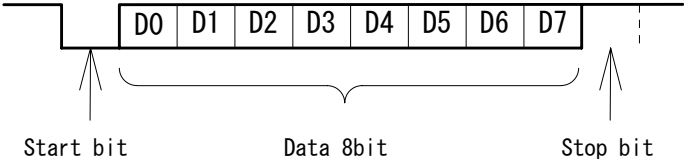

4. Message composition

4.1 Standard type

Transmits one command per a message.

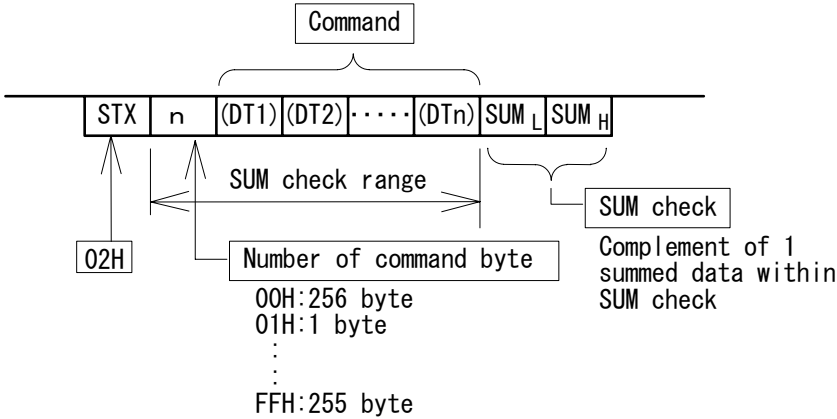

#### 4.2 Normal response

Returns ACK when the received message has no transfer errors.

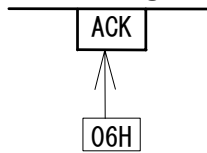

#### 4.3 Abnormal response

Returns NAK when the received message has transfer errors.

Repeat the message when received NAK.

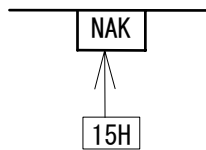

#### 4.4 Example of standard type message (Case of the HV-C20 color camera "BAR/CAM:BAR" command)

STX	:	02H
n	:	04H (4 byte commands)
DT1~DT4	:	20H 08H 01H FEH
SUM	:	04H+20H+08H+01H+FEH=01H 2BH
Complement of 1 summed data	:	FEH D4H (SUM <sub>H</sub> :FEH, SUM <sub>L</sub> :D4H)

Therefore, the message composition of "BAR/CAM:BAR" is shown below.

**02H 04H 20H 08H 01H FEH D4H FEH**

## 5. Configuration of command

Note: For details, see the command list for each camera.

### 5.1 ON/OFF control commands (Setting command of each function, response request commands, response commands)

#### (1) Setting commands

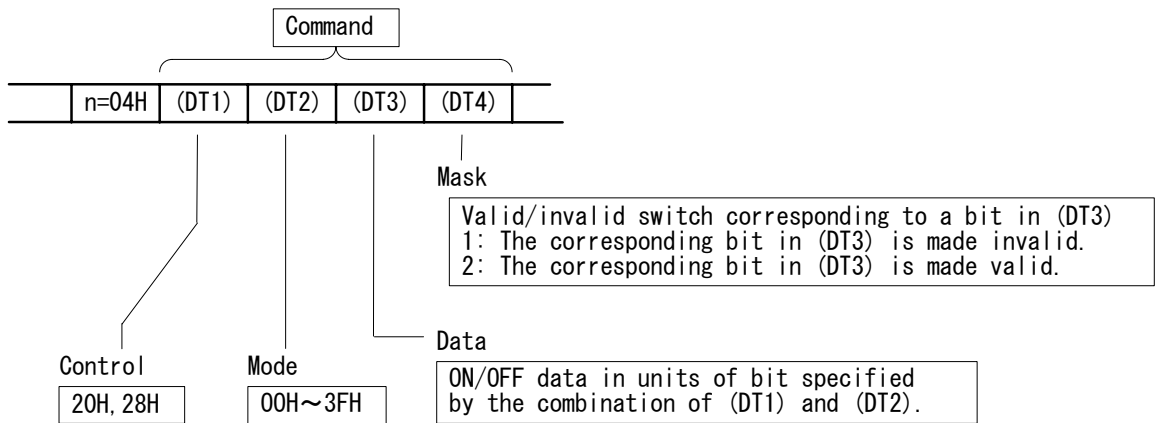

#### (2) Response request commands

Request the data specified by the mode of setting commands.

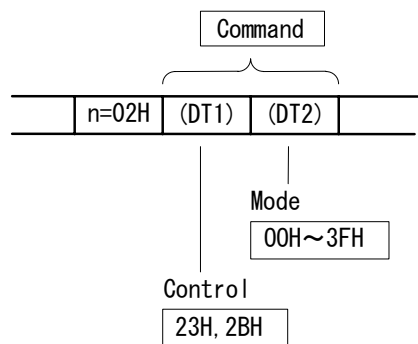

#### (3) Response commands

Response the data specified by the mode of setting commands.

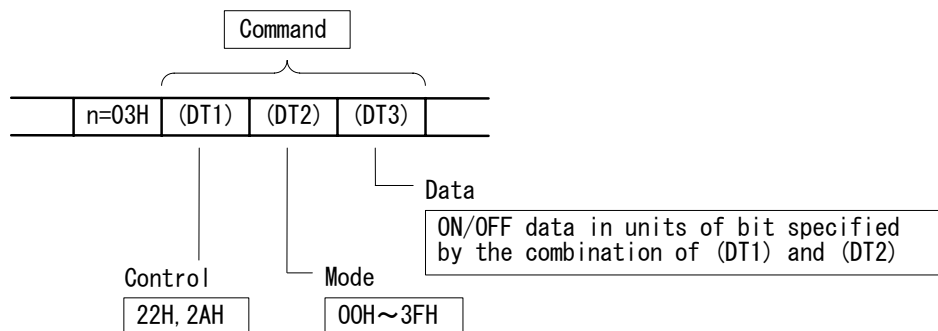

5.2 Analog control commands (Setting commands of each analog data, response request command, response commands)

(1) Setting commands

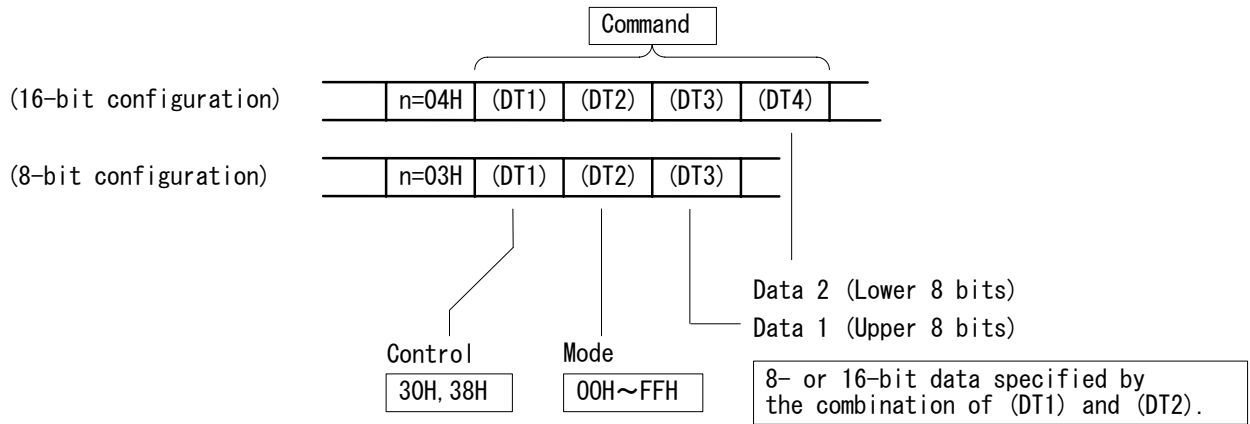

(2) Response request commands

Request the data specified in the mode of setting commands.

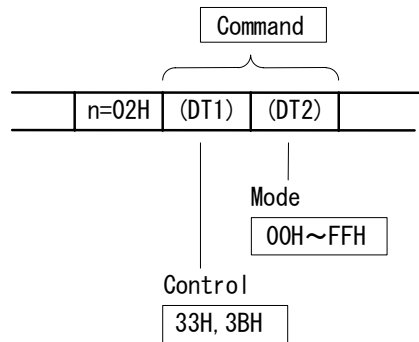

(3) Response commands

Response the data specified in the mode of setting commands.

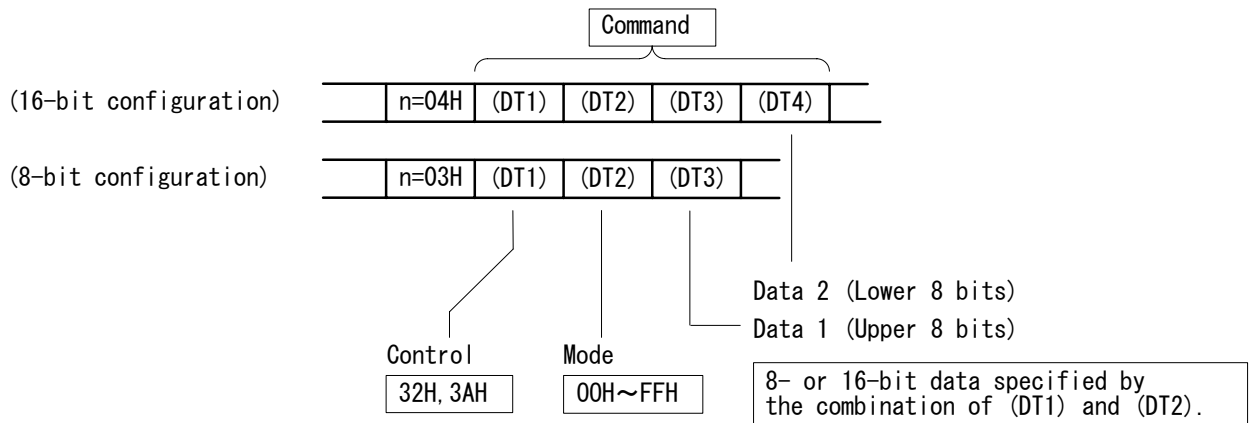

5.3 Auto function control commands (Setting (execution) commands of each auto function, response (result of execution) commands)

(1) Setting commands

Execute the auto functions including auto white balance and auto black balance.

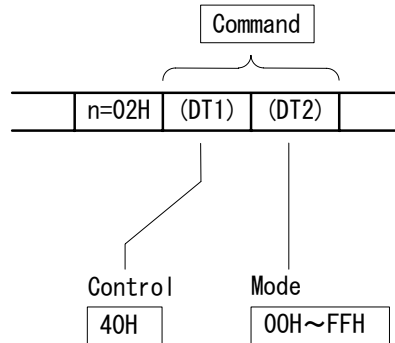

(2) Response commands

Return the result after executing the auto functions including auto white balance and auto black balance.

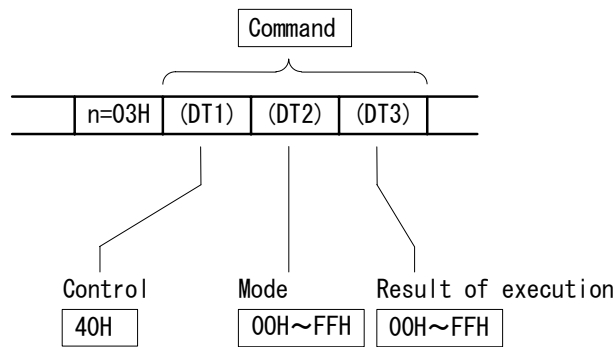

5.4 Character-string display control commands

(1) Setting commands

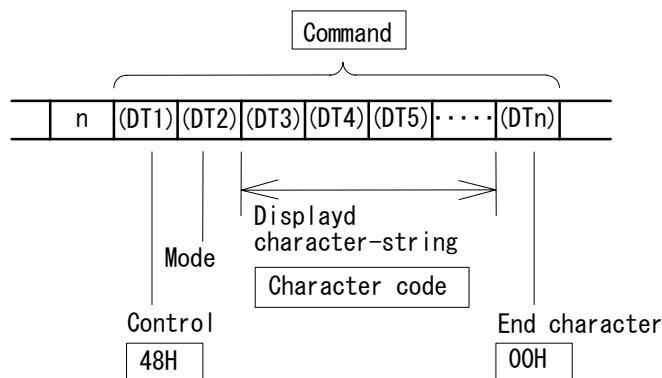

Note: Response request commands and response commands are not included in the character-string display control commands.

## 5.5 File control commands

### (1) Setting commands

Load, save and clear the specified files in a batch.

The number of bytes and function of a command differ from camera to camera. For details, see the command list for each camera.

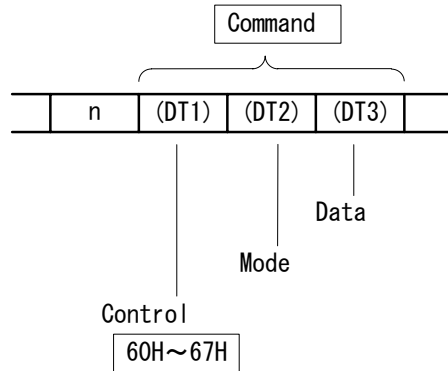

## 5.6 Status read commands (Read the model designation, version, etc. of a camera.)

### (1) Response request commands

Request the data specified by mode.

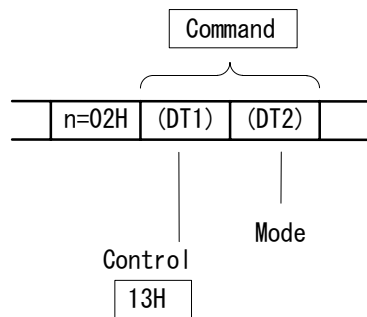

### (2) Response commands

Response the data corresponding to mode.

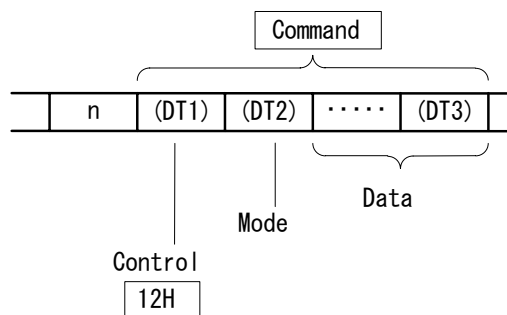

## Technical information: Command List for HV-F22CL/F31CL Remote Control

(Rev0. 90)

12. jul. 2004

The Hitachi HV-F22/F31CL series color cameras are provided with the functions which can be controlled from a PC. This information is prepared to explain the commands corresponding respective control items. For remote control procedure, see Technical Information entitled Protocol for remote control.

### 1. ON/OFF control commands (Setting commands, response request commands, response commands)

Note 1. Set character S listed in the (DT4) column to 0 to control a camera, and 1 not to control it.

2. Setting data can be backed up to the EEPROM by the command MEMORY BACK UP.

In the case of the last of the name of the column of (DT3) is described as ON or OFF, (DT3) becomes ON or OFF as the name in case of 1 and (DT3) becomes the opposite condition in case of 0.

(Example)

KNEE OFF : Bit 2 of (DT3)

OFF : (20,02,04,FB) / ON : (20,02,00,FB)

(DT1)	(DT2)	(DT3)		(DT4)
CTL	MODE	Bit	Item	MASK
20H 23H 22H	02H	0		1
		1	GAMMA OFF	S
		2	KNEE OFF	S
		3		1
		4	SHARPNESS OFF	S
		5	SHADING OFF	S
		6	MASKING ON	S
		7		1

(DT1)	(DT2)	(DT3)		(DT4)	
CTL	MODE	Bit	Item	MASK	
20H 23H 22H	04H	0		1	
		1		1	
		2	WHITE BAL MODE	0	S
		3		1	S
		4	GAIN MODE	0	S
		5		1	S
		6			1
		7	AUTO KNEE OFF		S
	05H	0	SHUTTER MODE	0	S
		1		1	S
		2		2	S
		3			S
		4			S
		5			S
		6			S
		7			S
	06H	0			1
		1			1
		2			1
		3			1
		4			1
5				1	
6				1	
7		FLARE OFF		S	

#### WHITE BAL MODE

	-	MEMORY	AUTO	-	(DT4)
0	0	1	0	1	F3H
1	0	0	1	1	

#### GAIN MODE

	-	MANUAL	AUTO	-	(DT4)
0	0	1	0	1	CFH
1	0	0	1	1	

MANUAL : The setting of variable GAIN by  
"GAIN(2001H)" command is enable.

AUTO : AGC ON

#### SHUTTER MODE

	OFF	VAR.	AES	EXT	(DT4)
0	0	1	1	1	F8H
1	0	1	0	1	
2	0	0	1	1	

OFF :HV-F22 1/15sec, HV-F31 1/30sec

VARIABLE: The setting of variable shutter by "SHUTTER  
VARIABLE(3038H)" command is enabled.

AES : AES ON

EXT : External trigger mod

(DT1)	(DT2)	(DT3)		(DT4)	
CTL	MODE	Bit	Item	MASK	
20H 23H 22H	07H	0		1	
		1		1	
		2		1	
		3		1	
		4	ALC PEAK/AVE	0	S
		5		1	S
		6			1
		7			1
	08H	0	COLOR BAR ON		1
		1			S
		2			S
		3			S
		4	NEGA ON		1
		5			1
		6			S
	0BH	0			1
		1			1
		2			1
		3			1
		4			1
		5			1
6				1	
7	PAINT ENABLE ON			S	

**ALC PEAK/AVE**

	50/50	25/75	15/85	0/100	(DT4)
0	0	1	0	1	CFH
1	0	0	1	1	

**PAINT ENABLE ON**

if PAINT ENABLE ON(20,0B,80,7F),R/B Paint GAIN (3018H,301AH), R/B Paint BLACK(3021H,3023H) adjustment become effective.

(DT1)	(DT2)	(DT3)		(DT4)	
CTL	MODE	Bit	Item	MASK	
20H 23H 22H	11H	0		1	
		1		S	
		2		S	
		3		1	
		4		S	
		5		S	
		6		S	
		7	GL IN 75Ω/HIGH		S
	15H	0	D.N.R. MODE	0	S
		1		1	S
		2			1
		3			1
		4			1
		5			1
		6			1
		7			1
	17H	0			1
		1			1
		2	INDICATOR DISPLAY	0	S
		3		1	S
		4			1
		5			1
		6			1
		7			1

**GL IN 75Ω/HIGH**

75Ω	HIGH	(DT4)
0	1	7FH

**D.N.R. MODE**

	OFF	MODE1	MODE2	-	(DT4)
0	0	1	1	0	FCH
1	0	0	1	1	

**INDICATOR DISPLAY**

The indication mode of each detection area is chosen.

	OFF	WHT / BLK	-----	FOCUS GATE	(DT4)
0	0	1	0	1	F3H
1	0	0	1	1	

WHT/BLK : The detection indicator of WHT is displayed normally.

Detection indicator of ABB is displayed if ABB ON .

FOCUS GATE : The indicator of FOCUS GATE is displayed.

(DT1)	(DT2)	(DT3)		(DT4)
CTL	MODE	Bit	Item	MASK
20H 23H 22H	20H	0	(SHARPNESS)	0 S
		1	COLOR DTL	1 S
		2	PHASE ch1	2 S
		3		1
		4		1
		5		1
		6		1
	7		1	
	21H	0	(SHARPNESS)	0 S
		1	COLOR DTL	1 S
		2	PHASE ch2	2 S
		3		1
		4		1
		5		1
		6		1
	7		1	
	29H	0	(SHARPNESS)	0 S
		1	DTL BOOST FREQ	1 S
		2		1
		3		1
		4		1
5			1	
6			1	
7		1		
33H	0	PIXEL CORRECT ON	S	
	1		1	
	2		1	
	3		1	
	4		1	
	5		1	
	6		1	
7		1		

**(SHARPNESS) COLOR DTL PHASE ch1**

	R-Mg	Mg-B	B-Cy	Cy-G	G-Ye	Ye-R	-(R-Mg)	-(R-Mg)	(DT4)
0	0	1	0	1	0	1	0	1	F8H
1	0	0	1	1	0	0	1	1	
2	0	0	0	0	1	1	1	1	

This command is used with COLOR DTL PHASE (3059H).

**(SHARPNESS) COLOR DTL PHASE ch2**

	R-Mg	Mg-B	B-Cy	Cy-G	G-Ye	Ye-R	-(R-Mg)	-(R-Mg)	(DT4)
0	0	1	0	1	0	1	0	1	F8H
1	0	0	1	1	0	0	1	1	
2	0	0	0	0	1	1	1	1	

This command is used with COLOR DTL PHASE (306BH).

**(SHARPNESS) BOOST FREQ**

	LOW	MID	HIGH	---	(DT4)
0	0	1	0	1	3FH
1	0	0	1	1	

(DT1)	(DT2)	(DT3)		(DT4)	
CTL	MODE	Bit	Item	MASK	
20H 23H 22H	35H	0		1	
		1		1	
		2		1	
		3		1	
		4	COLOR DTL CH1 ON	S	
		5	COLOR DTL CH2 ON	S	
		6		1	
36H	36H	0	EXT TRIGGER MODE	0	S
		1		1	S
		2			1
		3			1
		4			1
		5	TRIGGER POLARITY		S
		6			1
		7			1
48H	48H	0	FLASH WIDTH	0	S
		1		1	S
		2			1
		3			1
		4			1
		5			1
		6			1
		7			1

**EXT TRIGGER MODE**

	MODE0	MODE1	---	---	(DT4)
0	0	1	0	1	FCH
1	0	0	1	1	

**TRIGGER POLARITY**

	NEGATIVE	POSITIVE	(DT4)
0	0	1	DFH

**FLASH PULSE WIDTH**

	-	NARROW	MID	WIDE	(DT4)
0	0	1	0	1	FCH
1	0	0	1	1	

NARROW:10us

MIDDLE :50us

WIDE :250us

(DT1)	(DT2)	(DT3)		(DT4)	
CTL	MODE	Bit	Item	MASK	
28H 2BH 2AH	00H	0		1	
		1		1	
		2		1	
		3		1	
		4		1	
		5		1	
		6		1	
		7	ALC GATE ON		S
	01H	0			
		1			
		2	SHADING MODE	0	S
		3		1	S
		4			
		5			
		6			
		7			
	08H	0	AGC LIMIT		0
		1	06H(+6dB) ~		0
		2	0CH(+12dB)		0
		3			0
		4			1
5				1	
6				1	
7				1	

**SHADING MODE**

	LUMINANCE	COLOR	FLAT	-	(DT4)
0	0	1	0	1	F3H
1	0	0	1	1	

(DT1)	(DT2)	(DT3)		(DT4)	
CTL	MODE	Bit	Item	MASK	
28H 2BH 2AH	10H	0	WHITE GATE ON	S	
		1		1	
		2		1	
		3		1	
		4		1	
		5		1	
		6		1	
		7	ATW SPEED	S	
	11H	0	ALC SPEED	0	S
		1		1	S
		2			1
		3			1
		4			1
		5			1
		6			1
7			1		

**ATW SPEED**

Sets real-time auto white balance response speed.

SLOW	STANDARD	(DT4)
0	1	BFH

**ALC SPEED**

It sets up it with the action speed of AGC and AES.

	SLOW	STANDARD	FAST	-	(DT4)
0	0	1	0	1	FCH
1	0	0	1	1	

(DT1)	(DT2)	(DT3)		(DT4)
CTL	MODE	Bit	Item	MASK
28H 2BH 2AH	20H	0	ALC GATE DATA1	S
		1		S
		2		S
		3		S
		4		S
		5		S
		6		S
		7		S
	21H	0	ALC GATE DATA2	S
		1		S
		2		S
		3		S
		4		S
		5		S
		6		S
		7		S
	22H	0	ALC GATE DATA3	S
		1		S
		2		S
		3		S
		4		S
		5		S
		6		S
		7		S
	23H	0	ALC GATE DATA4	S
		1		S
		2		S
		3		S
4		S		
5		S		
6		S		
7		S		
24H	0	ALC GATE DATA5	S	
	1		S	
	2		S	
	3		S	
	4		S	
	5		S	
	6		S	
	7		S	

**ALC GATE DATA1 ~8**

DATA1(28,20)The top data

DATA8(28,27) The bottom data

(MSB: The left end, LSB: The right end),

(Exsample)

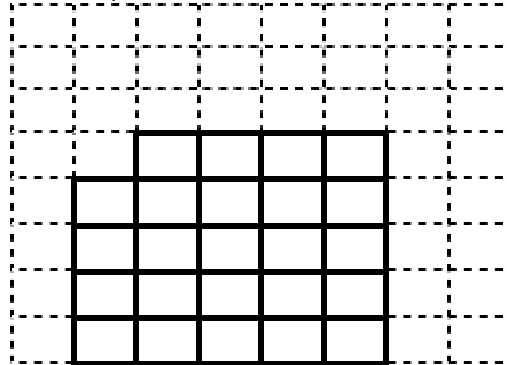

28, 20, 00, 00

28, 21, 00, 00

28, 22, 00, 00

28, 23, 3C, 00

28, 24, 7C, 00

28, 25, 7C, 00

28, 26, 7C, 00

28, 27, 7C, 00

(DT1)	(DT2)	(DT3)		(DT4)
CTL	MODE	Bit	Item	MASK
28H 2BH 2AH	25H	0	ALC GATE DATA6	S
		1		S
		2		S
		3		S
		4		S
		5		S
		6		S
		7		S
	26H	0	ALC GATE DATA7	S
		1		S
		2		S
		3		S
		4		S
		5		S
		6		S
		7		S
	27H	0	ALC GATE DATA8	S
		1		S
		2		S
		3		S
		4		S
		5		S
		6		S
		7		S

2. Analog control commands (Setting commands, response request commands, response commands)

Note 1. X in the DATA column is undefined.

2. Setting data can be backed up to the EEPROM by the command MEMORY BACK UP.

Item	(DT1)	(DT2)	(DT3) <sub>U</sub> , (DT4) <sub>D</sub>		
	CTL	MODE	DATA		
R GAIN	30H	00H	min	preset max	
B GAIN		02H	80XXH~00XXH~7FXXH ( SINGED)		
R GAMMA		03H	min	preset max	
B GAMMA		05H	80XXH~00XXH~7FXXH ( SINGED)		
FLARE		07H	-max	FLARE off +max	
			80XXH~00XXH~7FXXH ( SINGED)		
R paint GAIN		18H	min	preset max	
B paint GAIN		1AH	80XXH~00XXH~7FXXH ( SINGED)		
R paint BLACK		21H	min	preset max	
B paint BLACK		23H	80XXH~00XXH~7FXXH ( SINGED)		
TOTAL GAMMA		27H	min	preset max	
			80XXH~00XXH~7FXXH ( SINGED)		
KNEE POINT		28H	min	preset max	
			80XXH~00XXH~7FXXH ( SINGED)		
GAIN		2AH	0dB(min)	12dB(max)	
			80XXH~00XXH~40XXH ( SINGED)		
BRIGHTNESS ( MASTER BLACK)	2BH	min	preset max		
		80XXH~00XXH~7FXXH ( SINGED)			
SHARPNESS	2CH	min	preset max		
		80XXH~00XXH~7FXXH ( SINGED)			

Item	(DT1)	(DT2)	(DT3)U , (DT4)D
	CTL	MODE	DATA
H.PHASE	30H 33H	34H	-128    0    +127 80XXH~00XXH~7FXXH ( SINGED)
SHUTTER VARIABLE		38H	(F22)  4s ~ 1/15s ~ 1/100,000s FC5H~ 0000H ~ 036CH ( SINGED)
			(F31)  4s ~ 1/30s ~ 1/100,000s FF89H ~ 0000H ~ 0327H ( SINGED)
OVER RIDE		39H	-128    0    +127 80XXH~00XXH~7FXXH ( SINGED)
AUTO KNEE TRIM		3FH	LOW                    HIGH 80XXH~00XXH~7FXXH ( SINGED) (KNEE LEVEL of the "AUTO KNEE" condition is adjusted.)

—— [SHUTTER VARIABLE] THE CALCULATION METHOD ——

(Note) OFF\_VALUE: HV-F22 is "15", HV-F31 is "30".

( shutter speed  $\leq$  ( 1 / OFF\_VALUE ) )

①Exposure time → Value

$$nnnnh = \log_{0.99}(\text{OFF\_VALUE} \times \text{"Shutter Speed"})$$

②Value→Exposure time

$$\text{Shutter Speed}[\text{sec}] = \text{OFF\_VALUE} \times 0.99^{(nnnn)}$$

Example 1. Exposure time = 1/100sec (for HV-F31CL)

$$\begin{aligned} \text{Value:nnnn} &= \log_{0.99}(30 \times (1/100)) \\ &= \log(30 \times (1/100)) / \log 0.99 \doteq \underline{0078h} \end{aligned}$$

Example 2. Value:nnnn = 0078h (for HV-F31CL)

$$\text{Exposure time} = (1/30) \times 0.99^{(78h)} \doteq \underline{1/100(\text{sec})}$$

( shutter speed > ( 1 / OFF\_VALUE ) )

①Exposure time → Value

$$nnnnh = 10001h - ( \text{OFF\_VALUE} \times \text{"Shutter Speed"} )$$

②Value→Exposure time

$$\text{Shutter Speed}[\text{sec}] = ( 10001h - nnnnh ) / \text{OFF\_VALUE}$$

Example Exposure time = 1/7.5 sec (for HV-F31CL)

$$10001h - ( 30 \times (1/7.5) ) = \underline{FFFDh}$$

Item	(DT1)	(DT2)	(DT3) <sub>U</sub> , (DT4) <sub>D</sub>		
	CTL	MODE	DATA		
R HUE CROMA COMPEN	30H	40H	+ $\theta$	preset - $\theta$	
G HUE CROMA COMPEN		41H	80XXH~00XXH~7FXXH ( SINGED)		
B HUE CROMA COMPEN		42H			
Y HUE CROMA COMPEN		43H			
C HUE CROMA COMPEN		44H			
M HUE CROMA COMPEN		45H			
R SAT CROMA COMPEN	32H	46H	min	max	
G SAT CROMA COMPEN		47H	80XXH~00XXH~7FXXH ( SINGED)		
B SAT CROMA COMPEN		48H			
Y SAT CROMA COMPEN		49H			
C SAT CROMA COMPEN		4AH			
M SAT CROMA COMPEN		4BH			
MASTER SAT CROMA COMPEN		52H			
(SHARPNESS) DTL LEVEL DEPEND		53H	Dependent level setting		
			Low High 80XXH~00XXH~7FXXH ( SINGED)		
(SHARPNESS) DTL CRISP		54H	Crispness level setting		
			0 max 80XXH~00XXH~7FXXH ( SINGED)		
(SHARPNESS) DTL HV BALANCE		55H	Balance setting for horizontal and vertical detail amount		
			H<V H=V H>V 80XXH~00XXH~7FXXH ( SINGED)		
(SHARPNESS) COLOR DTL ch1 LEVEL		58H	Sets color detail level		
			0 1 2(magnification) 80XXH~00XXH~7EXXH Balance setting for horizontal and vertical detail amount		
(SHARPNESS) COLOR DTL ch1 PHASE		59H	Sets color detail phase		
			-128 0 127 80XXH~00XXH~7CXXH		
(SHARPNESS) COLOR DTL ch1 WIDTH		5AH	Selects color phase range for setting		
			-128(-120°) 0(0°) 127(+120°) 80XXH ~ 00XXH ~ 7FXXH (SINGED)		
(SHARPNESS) COLOR DTL ch2 LEVEL		6AH	Sets color detail level		
			0 1 2(magnification) 80XXH~00XXH~7EXXH (SINGED: Upper 7 bits are effective. 128 steps.)		
(SHARPNESS) COLOR DTL ch2 PHASE		6BH	Sets color detail phase		
			-128 0 127 80XXH~00XXH~7CXXH		
(SHARPNESS) COLOR DTL ch2 WIDTH		6CH	Selects color phase range for setting		
			-128(-120°) 0(0°) 127(+120°) 80XXH ~ 00XXH ~ 7FXXH (SINGED)		



### 3. Auto function control commands (Setting commands, response commands)

(Note) As for the executive result, a memory is done.

Item	Setting commands		Response commands		
	(DT1)	(DT2)	(DT1)	(DT2)	(DT3)
	CTL	MODE	CTL	MODE	RESULT
AUTO WHITE	40H	10H	40H	00H	00H:"OK" 11H: "NG CHANGE TO CAM" 12H: "NG CHANGE TO MEMORY MODE" 13H: "NG LOW LIGHT" 14H: "NG HIGH LIGHT" 15H: "NG C.TEMP.HIGH" 16H: "NG C.TEMP.LOW" 18H: "NG ???" 24H: "NG LONG SHUTTER MODE CHANGE SHUTTER MODE" 25H: "NG EXT TRIGGER CHANGE SHUTTER MODE"
AUTO BLACK	40H	20H	40H	00H	00H:"OK" 11H:"NG CHANGE TO CAM" 18H:"NG ???"
AUTO SHADING	40H	30H	40H	00H	00H:"OK" 11H:"NG CHANGE TO CAM" 13H:"NG LOW LIGHT" 14H:"NG HIGH LIGHT" 18H: "NG ???" 24H:"NG LONG SHUTTER MODE CHANGE SHUTTER MODE" 25H:"NG EXT TRIGGER CHANGE SHUTTER MODE"

#### 4. SCENE file select

(Note) Every time "SCENE FILE NO." is changed, "SCENE FILE NO." does a memory.

Item	(DT1)	(DT2)	(DT3)
	CTL	CTL	CTL
FILE-1	60H	01H	01H
FILE-2			02H
FILE-3			03H
FILE-4			04H
PRESET			FFH

#### 5. Memory backup

The change setting data can be backed up to the EEPROM.

(1) In a bundle memory backup

Item	(DT1)	(DT2)
	CTL	CTL
MEMORY BACK UP(ALL)	61H	02H

(2) One item memory backup

Item	(DT1)	(DT2)	(DT3)	Remark
	CTL	CTL	CTL	
MEMORY BACK UP2	65H	20H	XXH	ON/OFF Command
		28H	XXH	ON/OFF Command
		30H	XXH	Analog Command

The same value as DT1 and DT2 of when that command to, DT2, DT3 setting are set up.

(3) Only an optional scene file, memory backup.

(Note)The item of the menu screen that "FILE SEL" is indicated is the item of the scene file.

Item	(DT1)	(DT2)	(DT3)
	CTL	CTL	CTL
FILE-1	61H	01H	01H
FILE-2			02H
FILE-3			03H
FILE-4			04H

#### Note

The memory backup writes data to the address of memory IC which was assigned in the unit of a command. The rewriting guarantee number to the same address of memory IC that is using with the camera is becoming 100,000 times. Therefore, please pay attention in the case that a memory backup command is used.

6. States read (Response request commands, response commands)

Item	(DT1)	(DT2)	(DT3),(DT4),(DT5)
	CTL	MODE	RESULT
CAMERA TYPE	13H	00H	(DT3) 6AH: HV-F22, 6BH:HV-F31
CAMERA VERSION	12H	01H	Ver.(DT3).(DT4) (DT5)....ASCII code
FILE No.		04H	(DT3) 01H:FILE-1,02H:FILE-2,03H:FILE-3,04H:FILE-4,FFH:PRESET

8. INITIALIZE COMMANDS

Item	(DT1)	(DT2)	(DT3)
	CTL	CTL	CTL
FACTORY INITIALIZE	90H	00H	FFH