

# HITACHI

---

---

## Hitachi Denshi America, Ltd.

150 Crossways Park Drive, Woodbury, N.Y. 11797  
Tel: (516) 921-7200 Fax: (516) 496-3718

# Remote control protocol and command data For KP-F120

## 1. Comms\* specifications

Sync system	: Start-stop sync
Bit rate	: 9600 bps
Data length	: 8 bits
Start bit	: 1
Stop bits	: 2
Parity	: None
Bit transfer	: LSB first

\*Comms : Communications

## 2. Comms control

The remote control software controls all communications.

Data send/receive (BSC handshake) is by transferring TEXT data to the camera controller chip.

## 3. Comms procedure

- The following pages indicate the camera controller chip and remote control software data protocol. In the description, the camera is designated as slave and the software as master.
- Receive protect timer (time out error)  
The receive protect timer for master and slave processes is 1 second.  
For example, if 1 block of TEXT data is being received, if the data interval exceeds 1 second, error is produced and the data are lost.  
An acknowledgment of data receipt is not produced.

**a) Transmission from master (normal process)**

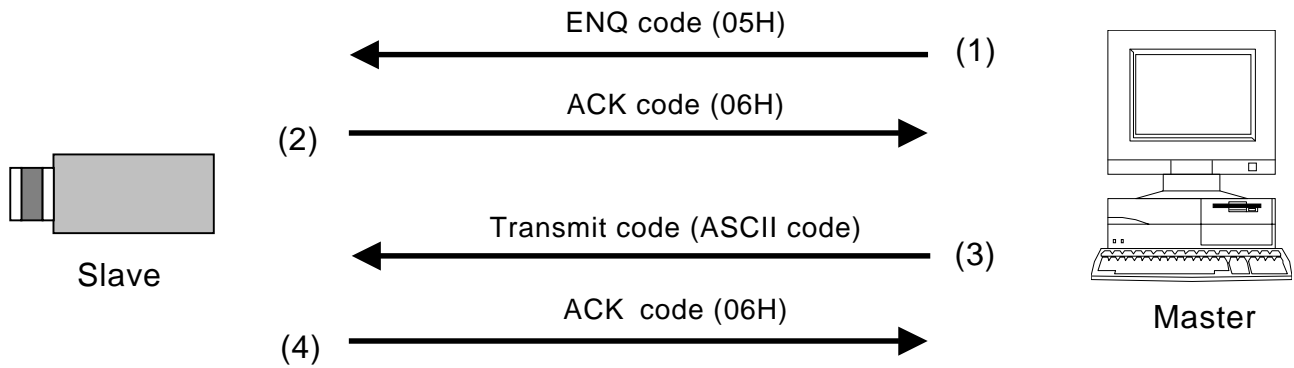

(1) Session starts when ENQ is sent from master to slave.

(2) Slave acknowledges by returning ACK to master.

(3) Master sends data to slave.

(4) Slave acknowledges receipt of data by again returning ACK to master and end the handshake.

**b) Master reads data (normal process)**

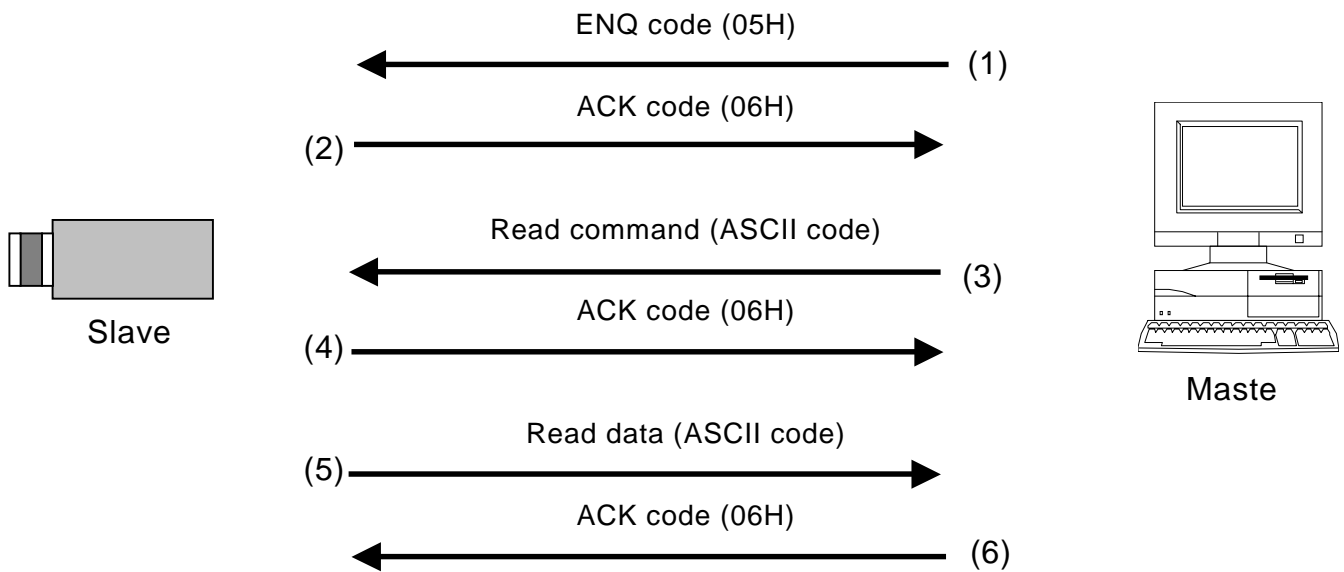

(1) Session starts when ENQ is sent from master to slave.

(2) Slave acknowledges by returning ACK to master.

(3) Master sends read data command to slave.

(4) Slave receives read data command, then acknowledges by returning ACK code to master.

(5) Slave sends read data to master.

(6) Master receives read data, then acknowledges by returning ACK code to slave.

**c) Data transmitted by master (control abort process)**

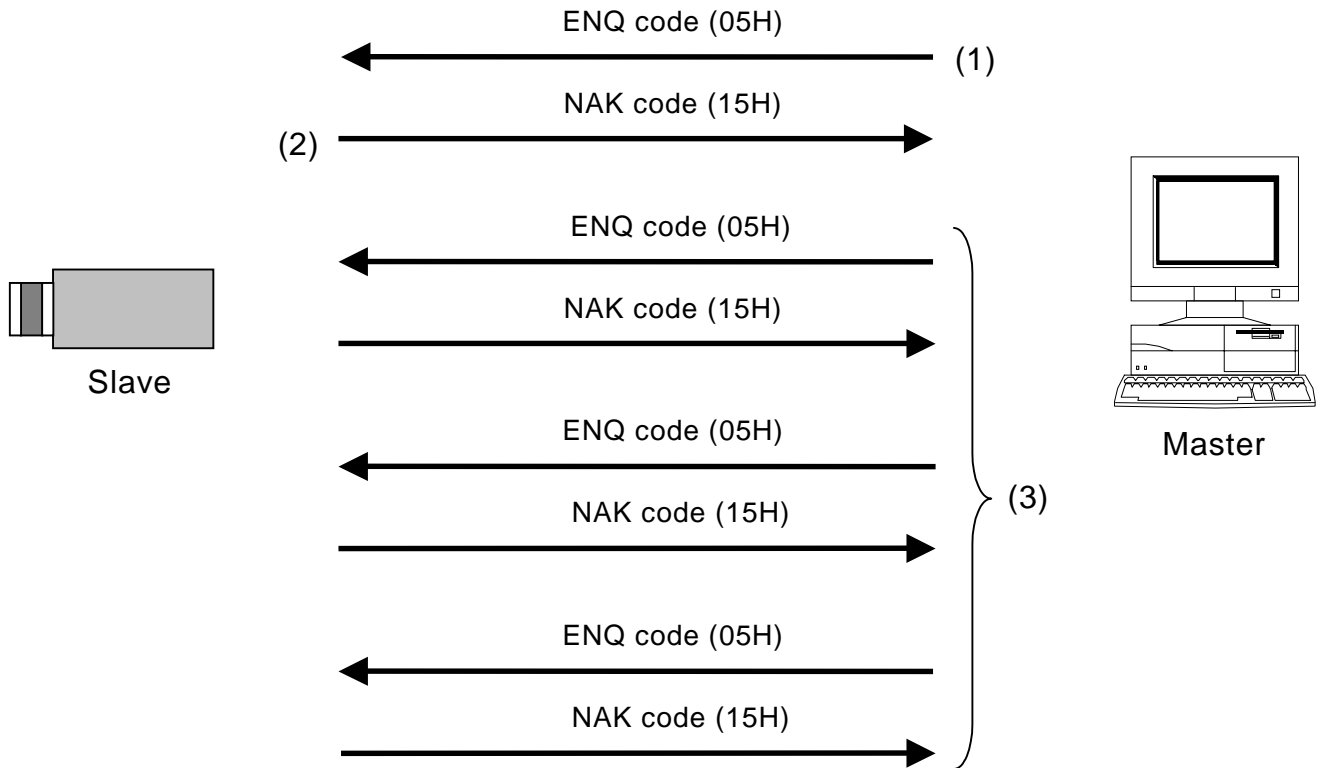

(1) Master sends ENQ code to slave.

(2) Since ACK code cannot be sent, slave sent NAK code to master.

(3) Sequence is repeated 3 times in attempts to retransmit. After receiving the 3rd successive NAK code, comms control is aborted.

**d) Data transmitted by master (data error process)**

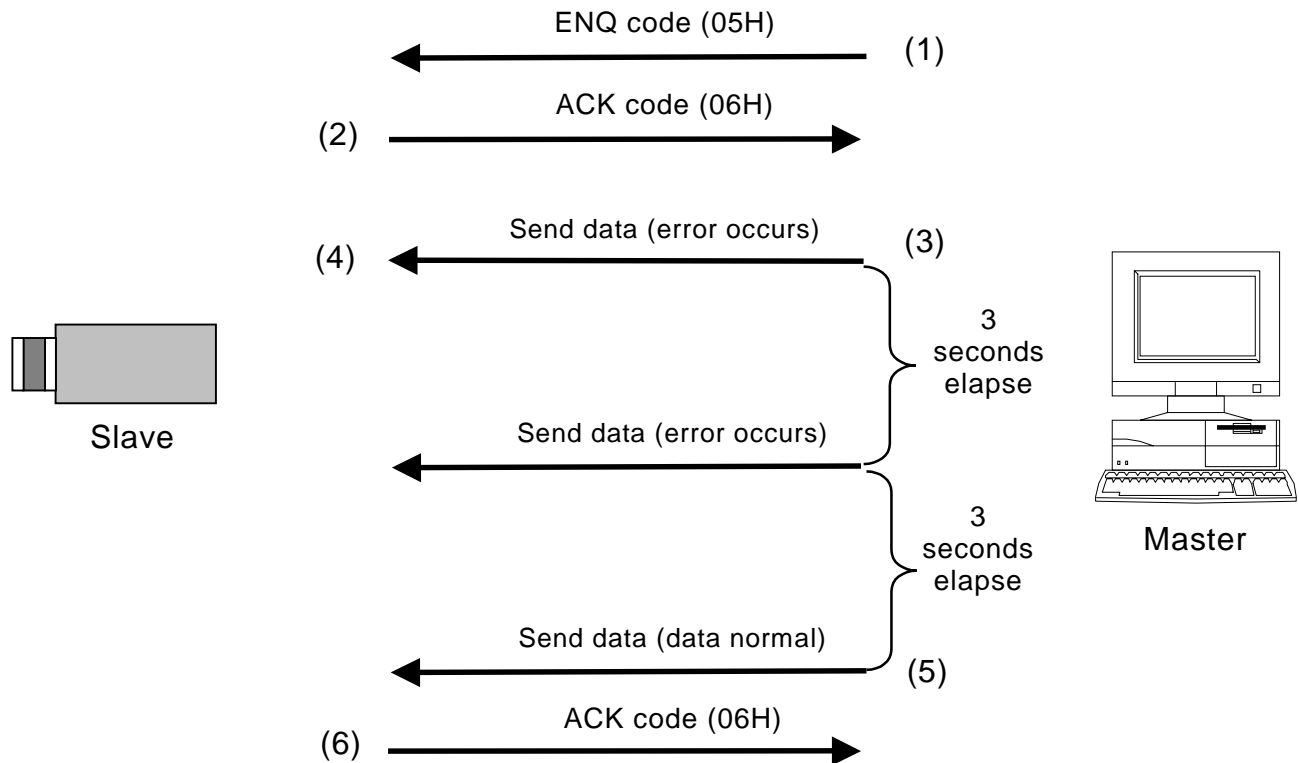

(1) Session starts when ENQ is sent from master to slave.

(2) Slave acknowledges by returning ACK to master.

(3) Master sends data, but error detected (framing, over-run error).

(4) Slave detects error and does not accept data.

(5) Sequence 3 and 4 repeats, then master transfers normal data.

(6) Slave detects normal data and returns ACK code to master to end the session.

**e) Data frame error (Master transmission)**

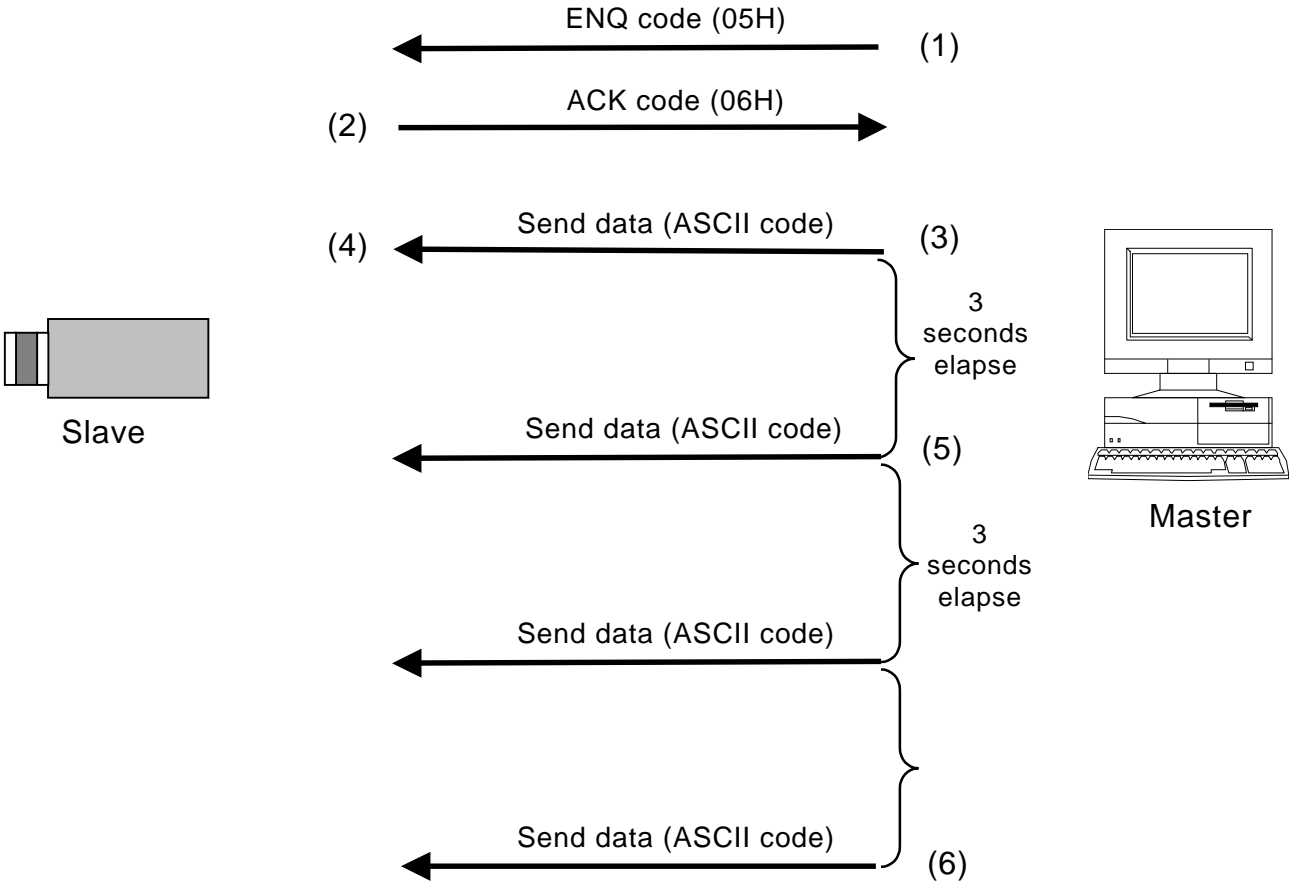

(1) Session starts when ENQ is sent from master to slave.

(2) Slave acknowledges by returning ACK to master.

(3) Master sends data.

(4) For some reason, slave does not receive data.

(5) Master does not receive acknowledgment to the send code and repeats the

sequence every 3 seconds for 3 times.

(6) If unsuccessful after 3 attempts, master aborts the sequence and ends communication.

### f) Transmission frame error (Master receive)

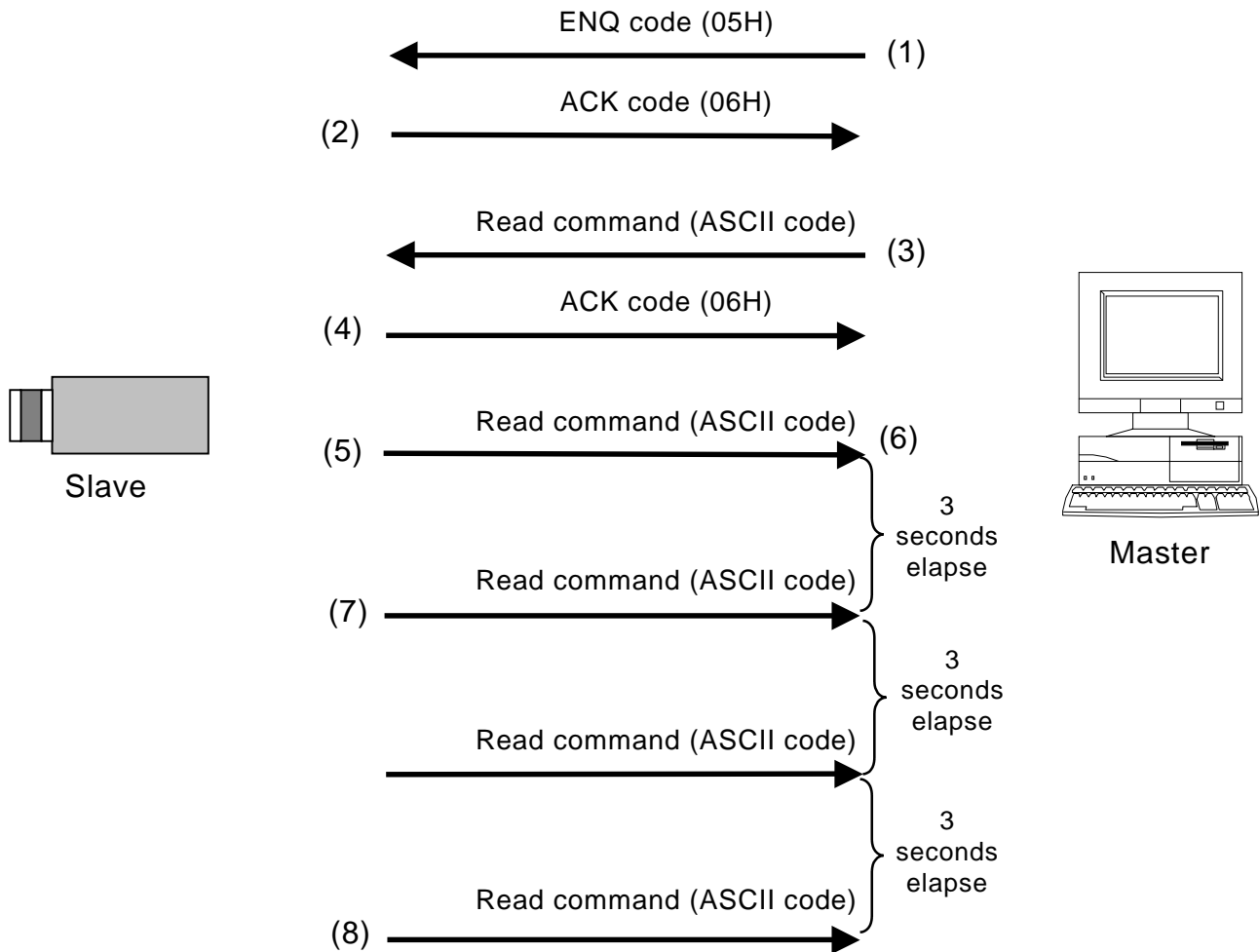

(1) Session starts when ENQ is sent from master to slave.

(2) Slave acknowledges by returning ACK to master.

(3) Master sends read command.

(4) Slave returns ACK code to acknowledge read command.

(5) Slave sends corresponding read data to master.

(6) For some reason, master fails to receive read data.

(7) Slave fails to receive acknowledgment of read data and attempts to resend every 3 seconds for 3 times.

(8) After the third failure, slave aborts the sequence and ends communication.

#### 4. Comms command Text data format

(a) Send data and read command data (master to slave)

1) Command data are converted into ASCII code and transmitted.

2) Comms byte quantity is 18.

3) Comms data format (transmission sequence).

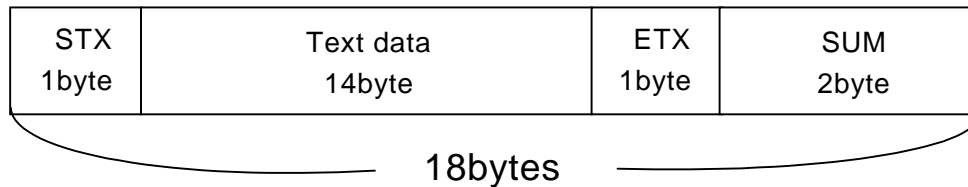

- STX : Code indicating start of text. 1 byte (02H)
- Text data : Transmit / receive data. 14 byte (ASCII code)
- ETX : Code indicating end of text. 1 byte (03H)
- SUM : XOR result (FFH) of adding STX, Text data and ETX. 2 byte

4) Text data format details (transmission sequence).

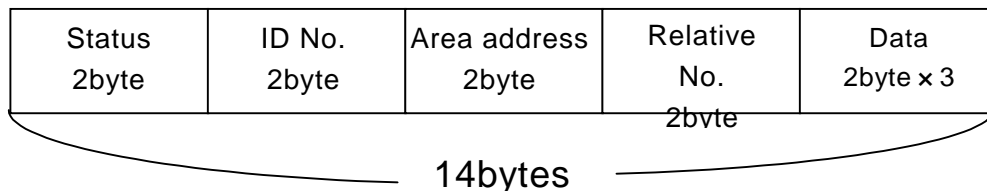

- Status : Transmission data status. 2 bytes (ASCII code)  
Used for EEPROM write (0: write absent, 1: write present)
- ID No. : Identification (camera ID) number set by user.  
However, ID no. FFH is global address and all data are changed.  
2 bytes (ASCII code)
- Area address : Sets number (0 to 255) for each adjustment item.  
2 bytes (ASCII code)

- Relative No. : Sets number determined by each area address.  
2 bytes (ASCII code)
- Data (note) : Sets data to be transmitted.  
2 bytes x 3 (ASCII code)

(b) Read (receive) data (slave to master)

- 1) : Command data are converted into ASCII code and transmitted.
- 2) : Comms byte quantity is 10.
- 3) : Comms data format (transmission sequence)

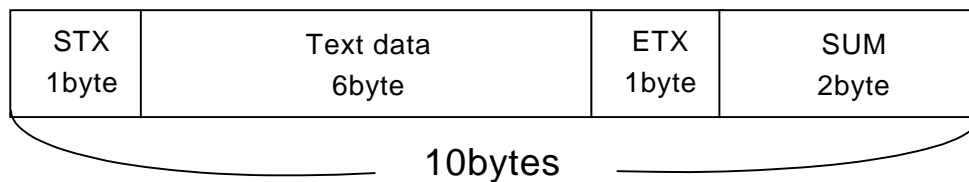

- STX : Code indicating start of text. 1 byte (02H)
- Text data : Transmit / receive data. 6 byte (ASCII code)
- ETX : Code indicating end of text. 1 byte (03H)
- SUM : XOR result (FFH) of adding STX, Text data and ETX.  
2 byte

4) : Text data details (transmission sequence)

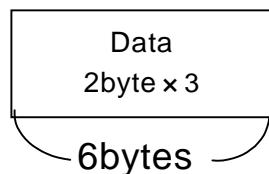

- Data (note) : Sets data to be transmitted.  
2 bytes x 3 (ASCII code)

Area address	Data type	Data bytes	1st byte	2nd byte	3rd byte
1 , 3	Common data	1	Data	0	0
		2	Upper	Lower	0
		3	Upper	Mid	Lower
2 , 4	State data	1	Data	0	0
		2	Lower	Upper	0
		3	Lower	Mid	Upper

**Note : Data transfer sequence**

Common data are transferred from upper data, state data are transferred from lower data.

6 . Protocol table

Read command data ( Note: 1 to 7 and SUM require conversion to ASCII code. )

Item	STX	1	2	3	4	5	6	7	ETX	SUM
		STATUS	ID No.	AREA ADDRESS	RELATIVE NO	DATA				
MODE	02	00	FF	03	04	00	00	00	03	27
SHUTTER SPEED	02	00	FF	03	08	00	00	00	03	23
GAIN	02	00	FF	03	0C	00	00	00	03	18
BLACK LEVEL	02	00	FF	03	17	00	00	00	03	23
AREA	02	00	FF	03	19	00	00	00	03	21
HD RESET	02	00	FF	03	02	00	00	00	03	29
CLK PHASE(ON/OFF)	02	00	FF	03	05	00	00	00	03	26
CLK PHASE	02	00	FF	03	0A	00	00	00	03	1A
TRIGGER	02	00	FF	03	10	00	00	00	03	2A

5. Protocol table

Transmit data (Note: 1 to 7 and SUM require conversion to ASCII code.)

1/2

Item	STX	1	2	3	4	5	6	7	ETX	SUM	
		STATUS	ID No.	AREA ADDRESS	RELATIVE NO.	DATA					
MODE	NORMAL	02	01	FF	01	04	00	00	00	03	28
	1TRIGGER	02	01	FF	01	04	01	00	00	03	27
	2TRIGGER	02	01	FF	01	04	02	00	00	03	26
	4× accelerated mode	02	01	FF	01	04	03	00	00	03	25
	4× accelerated mode+1TRIG	02	01	FF	01	04	04	00	00	03	24
	Smear reduction mode+1TRIG	02	01	FF	01	04	05	00	00	03	23
	Smear reduction mode+2TRIG	02	01	FF	01	04	06	00	00	03	22
	Smear reduction mode + 4× accelerated mode+1TRIG	02	01	FF	01	04	07	00	00	03	21
	NORMAL SHUTTER	02	01	FF	01	04	08	00	00	03	20
	FIXED SHUTTER	02	01	FF	01	04	09	00	00	03	1F
	Smear reduction mode + FIX. SHUT	02	01	FF	01	04	0A	00	00	03	17
	PARTIALSCAN(NOR.)(CENTER)	02	01	FF	01	04	0B	00	00	03	16
	PARTIALSCAN(NOR.)(UPPER)	02	01	FF	01	04	0C	00	00	03	15
	PARTIALSCAN(1TRIG)(CENTER)	02	01	FF	01	04	0D	00	00	03	14
	PARTIALSCAN(1TRIG)(UPPER)	02	01	FF	01	04	0E	00	00	03	13
2× accelerated mode	02	01	FF	01	04	0F	00	00	03	12	
HUTTER SPEED	1/30	02	01	FF	01	08	00	00	00	03	24
	1/60	02	01	FF	01	08	01	00	00	03	23
	1/125	02	01	FF	01	08	02	00	00	03	22
	1/250	02	01	FF	01	08	03	00	00	03	21
	1/1000	02	01	FF	01	08	04	00	00	03	20
	1/2000	02	01	FF	01	08	05	00	00	03	1F
	1/10000	02	01	FF	01	08	06	00	00	03	1E
1/50000	02	01	FF	01	08	07	00	00	03	1D	
GAIN	MIN(0)	02	01	FF	01	0C	00 (*1)	00	00	03	19
	MAX(15)	02	01	FF	01	0C	0F (*1)	00	00	03	03
BLACK LEVEL	MIN(0)	02	01	FF	01	17	00 (*2)	00	00	03	24
	MAX(50)	02	01	FF	01	17	32 (*2)	00	00	03	1F

(\*1)From 00, it is the range of 0F and is variable.

(\*2)From 00, it is the range of 32 and is variable.

Transmit data (Note: 1 to 7 and SUM require conversion to ASCII code.)

2/2

Item	STX	1	2	3	4	5	6	7	ETX	SUM	
		STATUS	ID No.	AREA ADDRESS	RELATIVE NO.	DATA					
AREA	16H	02	01	FF	01	19	00	00	00	03	22
	32H	02	01	FF	01	19	01	00	00	03	21
	64H	02	01	FF	01	19	02	00	00	03	20
	128H	02	01	FF	01	19	03	00	00	03	1F
	256H	02	01	FF	01	19	04	00	00	03	1E
	512H	02	01	FF	01	19	05	00	00	03	1D
HD RESET	ON	02	01	FF	01	02	00	00	00	03	2A
	OFF	02	01	FF	01	02	01	00	00	03	29
CLK PHASE (ON/OFF)	ON	02	01	FF	01	05	00	00	00	03	27
	OFF	02	01	FF	01	05	01	00	00	03	26
CLK PHASE	MIN (0)	02	01	FF	01	0A	00 (*3)	00	00	03	1B
	MAX (15)	02	01	FF	01	0A	0F (*3)	00	00	03	05
TRIGGER	NORMAL	02	01	FF	01	10	00	00	00	03	2B
	INVERT	02	01	FF	01	10	01	00	00	03	2A

(\*3)From 00, it is the range of 0F and is variable.