

Gigabit Ethernet

Progressive Scan CCD Camera

KP-F140GV

Specifications (Preliminary) Ver2.4

1. General

The KP-F140GV is single CCD type camera which utilized the progressive scan CCD image sensor with square pixel for SXGA format of 1/2-inch.

By adoption of a Gigabit Ethernet interface, high-speed connection of maximum of 1 Gbps can be possible. Moreover, by using hub or switcher, construction of multiple camera system can be easily performed.

2. Principal features

1) High resolution

The 1/2-inch 1,450,000 pixels square lattice progressive scan CCD achieve a high resolution and of 1360(H) x 1024(V) (SXGA).

2) Gigabit Ethernet interface

High-speed serial interface Gigabit Ethernet is supported and direct connection is possible to PC by the diameter cable of thin as compared with parallel output. Cable length can be extended to maximum 100m without hub and switcher.

3) GigE Vision correspondence

Based on industrial camera interface standard GigE Vision, a maximum of 1 Gbps high speed data transmit is available and suitable for image processing.

4) CCD drive functions

·Auto electronic Shutter mode (AES)

Adjusted automatically from 10 second to approx. 1/100,000 second.

·Variable electronic shutter mode

Variable at 1H steps from 10second to approx. 1/100,000 second.

5) External trigger

An external trigger signal input can be used to capture an image at desired timing for instant view or processing. The software trigger via a Gigabit Ethernet cable and the hardware trigger can deal with all trigger signals.

Hitachi Kokusai Electric

3. Specifications

- 1) Imaging device : 1/2-inch progressive scan interline CCD
(with on-chip microlenses)
 - Total number of pixels : 1434(H) x 1050(V)
 - No. of effective pixels : 1392(H) x 1040(V)
 - Unit cell size : 4.65(H) x 4.65(V) um (Square pixel)
- 2) Scanning system : Progressive scan
- 3) Frame rate : 30 fps (for all image format)
- 4) Sync system : Internal / external
- 5) Lens mount : C mount
- 6) Video signal output
 - Interface : Gigabit Ethernet
 - Protocol : GigE Vision compliant
 - Transfer rate : 1 Gbit per second
 - Image format : Mono 8/10bit
 - Image size : 1360(H) x 1024(V)
- 7) External sync signal
 - VD output : 5Vp-p plus minus 0.3V
 - Strobe out : 5Vp-p plus minus 0.3V
- 8) Standard sensitivity : 2000 lx F5.6
- 9) Electric shutter speed : Auto (AES) / Manual (VARIABLE)
From 10 second to approx. 1/100,000 second
- 10) External trigger shutter : Mode Fixed shutter
One trigger
VD Sync
Input Via Gigabit Ethernet cable (Software trigger)
12-pin connector (Hardware trigger)
Input level 5Vp-p plus minus 1V
- 11) Auto Exposure (ALC: Auto level control)
 - : Adjustable for video level
- 12) Gain : Auto / Manual (0dB to 18dB)
- 13) Gamma : OFF / ON
- 14) Sharpness : Adjustable
- 15) Brightness : Adjustable
- 16) Power supply : DC+12V plus minus 1V
- 17) Power consumption : Approx. 4.1W (DC+12V)

18) Ambient temperature

Operating : -10 °C to +50 °C / 30 to 80 %RH

Note : If operated continuously, be sure to use at less than +40 °C(104F) for long term stable performance.

Storage : -20 °C to +60 °C / 20 to 90 %RH

19) Vibration endurance : 68.65 m/s² or less

(10 to 200Hz, 30 minutes each on XYZ axes)

(Do not subject to strong vibration for long periods of time.)

20) Shock endurance : 490.3 m/s² or less (vertical, horizontal, once each face)

21) External dimensions : 44(W) x 29(H) x 72(D) mm

(not including lens and protrusions)

22) Mass : Approx. 140g (without lens)

23) Camera remote : Gigabit Ethernet control

24) Supplied equipment : Camera

CD-ROM (Operation manual / Driver soft)

25) Optional accessories : LAN cable (Enhanced category 5 or Category 6)

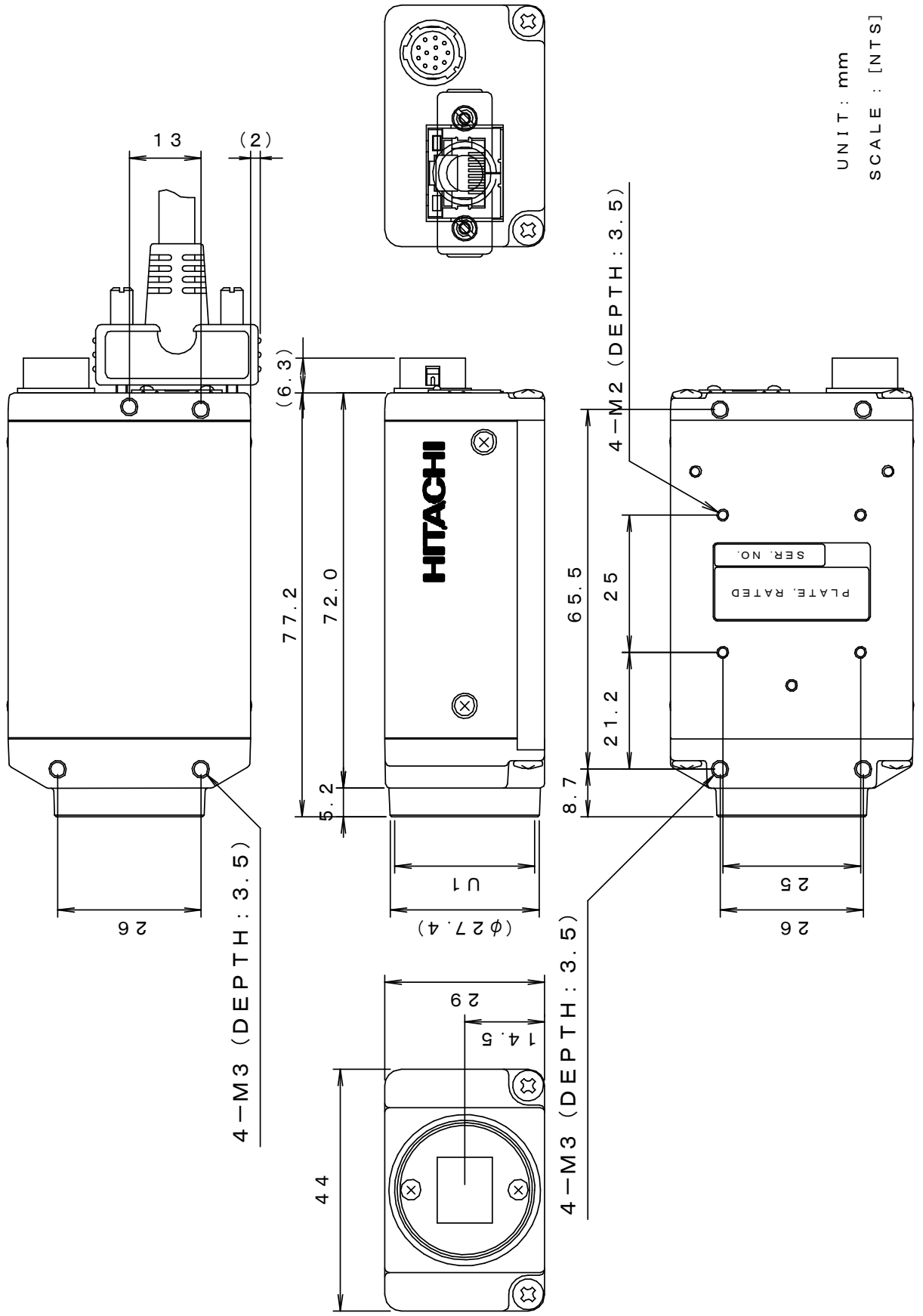

UNIT: mm

SCALE: [NTS]

4. Pin assignment

(1) Gigabit Ethernet connector

PIN NO.	Signal
1	TRP1+
2	TPR1-
3	TRP2+
4	TPR3+
5	TRP3-
6	TRP2-
7	TRP4+
8	TRP4-

Connector : RJ-45

(3) 12-pin connector

PIN NO.	Signal	PIN NO.	Signal
1	GND	7	TRIG/VD IN
2	+12V	8	GND
3	GND	9	N.C.
4	N.C.	10	FLASH / VD OUT
5	GND	11	N.C.
6	N.C.	12	GND

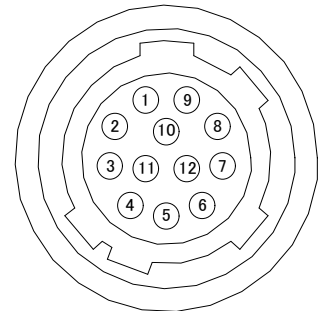

Connector (camera side) : SAMWOO SNH-10-12 (RPCB) or equivalent

Plug (matching cable plug) : Hirose HR10A-10P-12S (01) or equivalent

Please do not unplug and insert cable (camera cable) with a power supplied to a camera.
Install clamp filter (ZCAT 2035-0930A: TDK) at both ends (camera and video processor ends) in the CE marking legion.

Notice:

These specifications are subject to change without prior notice due to product improvement. Confirm the most recent specifications at time of order.

Hitachi Kokusai Electric certifies this product complies with the standard warranty conditions of Hitachi Kokusai Electric, and that quality control is implemented to the extent required to comply with these conditions.

Warranty and service:

- 1) The guarantee period is one year after the data purchase. However, the defects due to erroneous use or intentional act are excluded.
- 2) As the defect after expiration of the guarantee period, where product repair is possible, repair will be performed at charge.
- 3) The present Warranty pertains only to the camera unit. Secondary malfunctions attributable to camera failure as well as expenses incurred by disassembly and reassembly of the related system, are beyond the scope of this Warranty.
- 4) Compensation for loss of business, loss or damage to software, database and other contingent losses are beyond the scope of this Warranty.
- 5) Hitachi Kokusai Electric Inc. is not liable for the losses caused when the equipment is used in a system, use for business trades, production process, medical fields, crime prevention applications, etc.
- 6) The parts used in the equipment have their respective lives. The lives of such parts will be shortened under the environments of high temperature or high humidity. When the stable operation is required for a long time, it is recommended to perform periodical maintenance and inspection every year or every two years.