

Progressive scan monochrome CCD camera

KP-F30PCL

Specifications(Preliminary)

1. Specifications

(1) Imaging device	1/3-inch interline CCD
Total pixels	692 (H) x 504(V)
Effective pixels	659 (H) x 494(V)
Pixel size	7.4 (H) x 7.4 (V) um (square lattice)
(2) Sensing area	4.88 (H) x 3.66 (V) mm
(3) Scanning system	Non-interlaced
(4) Aspect ratio	4 : 3
(5) Frame rate	60frames/second (full pixel readout)
(6) Horizontal scanning frequency	31.468kHz
(7) Vertical scanning frequency	59.94 Hz
(8) Sync system	Internal
(9) Lens mount	C mount
(10) Flange focal distance	17.526 mm
(11) Video output	Digital output Camera Link Data : Base configuration 10bit x 1 Clk = 24.5454MHz
(12) VD reset	VD LVDS level, 59.94 Hz or less
(13) Resolution	Horizontal 500TV lines Vertical 490TV lines
(14) Sensitivity	400 lx, F4, 3200 K
(15) Minimum lamination	1.0 lx, F1.4, MAX GAIN, without IR cut filter
(16) Signal noise to ratio	50 dB

E400029541 1/18

DWN	<i>J. Katonaka</i>	<i>Oct 02 '06</i>	KP-F30PCL Specifications	Hitachi Kokusai Electric	<b>E400029541</b>		
DSGN	<i>K. Ueno</i>	<i>Oct 10 '06</i>			Rev.	<i>0</i>	1 / 18
CHKD	<i>S. Kanomata</i>	<i>Oct 11 '06</i>					
APPD	<i>M. Suzuki</i>	<i>Oct 11 '06</i>					

(17) Electronic shutter speed	1/60, 1/250, 1/500, 1/1000, 1/2000,1/4000,1/10000, 1/50000 second. Factory setting is off (1/60 second) or changeable by variable shutter (Minimum 1/100000 second)	A
(18) Gamma compensation	$\gamma = 1$	
(19) Frame on demand	Remote setting (fixed shutter, one trigger and reset control mode). Factory setting is all off.	
(20) Partial scan	Selectable start position and width of picture grabbing from 1H to 494H by 1H step.	B
(21) Power supply voltage	12 ± 1 VDC	
(22) Current consumption	Approx. 120 mA (Approx. 1.5 W)	
(23) Ambient, operating	0 to + 40°C (+32 to ; 104 F), less than 90 % RH	
Ambient, storage	-10 to + 50°C(+14 to +122 F), less than 70 % RH (Without Dew condensation)	
Note: If operated continuously, be sure to use at less than +40°C(104 F) for long term stable performance.		
(24) Vibration endurance	98 m/s <sup>2</sup> (Acceleration: constant) (10 to 200Hz,sweep:10 min,XYZ,30 min)	C
(25) Shock endurance	686 m/s <sup>2</sup> (Drop test, once each top, bottom, left and right)	
(26) External dimensions	29 (W) x 29 (H) x 29 (D) mm	
(27) Mass	Approx. 50 g	
(28) Remote control		D
(a) Signal system		
Control system	Start-stop synchronization system	
Transmission rate	9600 bps	
Data length	8 bits	
Start bit	1bit	
Stop bit	1bit	
Parity	None	
Bit transfer	LSB first	
(b) Communications control system		E
Full control by remote control software, data send/receive by text data transfer to camera microprocessor (BSC system handshake)		

E400029541 2/

DWN	/	.	.	KP-F30PCL Specifications	Hitachi Kokusai Electric	E400029541	Rev.	/	2 /	F
DSGN	/	.	.							
CHKD	/	.	.							
APPD	/	.	.							

(c) Control items

- |                            |  |
|----------------------------|--|
| 1. Shutter speed           | 1/60, 1/250, 1/500, 1/1000, 1/2000,<br>1/4000, 1/10000, 1/50000 second |
| 2. Variable shutter        | Minimum 1/100000 second  |
| 3. Mode                    | Fixed shutter, one trigger, reset control mode                         |
| 4. Gain                    | 0 to 18.5 dB(Approx. 0.04 dB step)                                     |
| 5. VD/FVAL                 | Factory setting: VD  |
| 6. HD/LVAL                 | Factory setting: HD  |
| 7. 8bit/10bit              | Factory setting: 10bit   |
| 8. HD reset/NON reset      | Factory setting: HD reset  |
| 9. Partial scan mode       |  |
| 10. VD reset mode          |  |
| 11. Trigger pulse polarity | Factory setting: POS   |

2. Composition

- (1) Camera (with IR cut filter)
- (2) Operating instructions

3. Optional accessories

- |                             |          |
|-----------------------------|----------|
| (1) Dummy glass (AR coated) | ARC1214  |
| (2) Tripod adaptor          | TA-F200S |

E400029541 3/

DWN	/	.	.	KP-F30PCL Specifications	Hitachi Kokusai Electric	E400029541		
DSGN	/	.	.			Rev.	/	3 /
CHKD	/	.	.					
APPD	/	.	.					

#### 4. Signal connection to connector

Pin No.	Signal	Pin No.	Signal
1	+12V	14	GND
2	TxOUT0(-)	15	TxOUT0(+)
3	TxOUT1(-)	16	TxOUT1(+)
4	TxOUT2(-)	17	TxOUT2(+)
5	TxCLKOUT0(-)	18	TxCLKOUT0(+)
6	TxOUT3(-)	19	TxOUT3(+)
7	Rx(+)[SERTC(+)]	20	Rx(-)[SERTC(-)]
8	Tx(-)[SERTFG(-)]	21	Tx(+)[SERTFG(+)]
9	TRIG-A/VD(-)[CC1(-)]	22	TRIG-A/VD(+)[CC1(+)]
10	TRIG-B(+)[CC2(+)]	23	TRIG-B(-)[CC2(-)]
11	NC[CC3(-)]	24	NC[CC3(+)]
12	NC[CC4(+)]	25	NC[CC4(-)]
13	GND	26	+12V

Connector (camera side)

SDR connector (Sumitomo 3M) or equivalent

- The digital out cable should be comprised of a twisted pair of wires having 100Ω characteristic impedance and an outer sheath shield type conductor.
  - Connect the shield (ground) of the digital out cable to the ground terminal of the video equipment, frame grabber, etc.
  - Install clamp filter (ZCAT3035-1330: TDK) at both ends (camera and video processor ends) in the CE making region.
  - Tx: Transmit data from camera to PC
  - Rx: Transmit data from PC to camera
- (Note)  
Please do not unplug and insert cable (digital out cable) with a power supplied to a camera.

#### 5. VD reset mode

When external VD pulse is inputted, internal HD/VD is reset.

External VD specification: 59.94 Hz or less

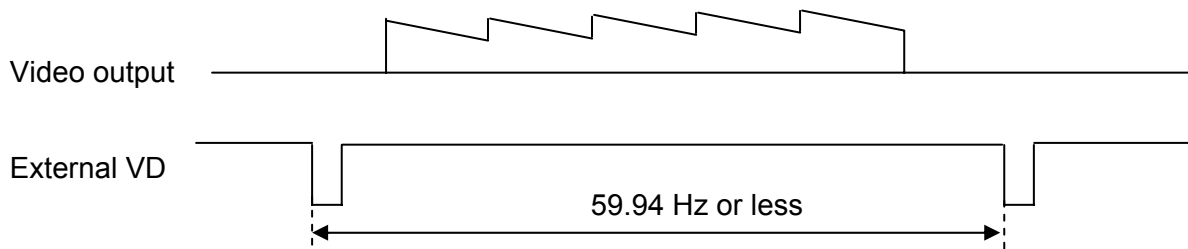

(Note) When external VD of 59.94Hz or more is input, electronic shutter has an equation between external VD and 59.94Hz.

E400029541 4/

DWN		.	.	KP-F30PCL Specifications	Hitachi Kokusai Electric	E400029541	
DSGN		.	.				
CHKD		.	.			Rev.	
APPD		.	.				4 /

## 6. Timing chart

6-1 Transmitter LVDS Output Pulse Position Measurement  
(a) 10bit

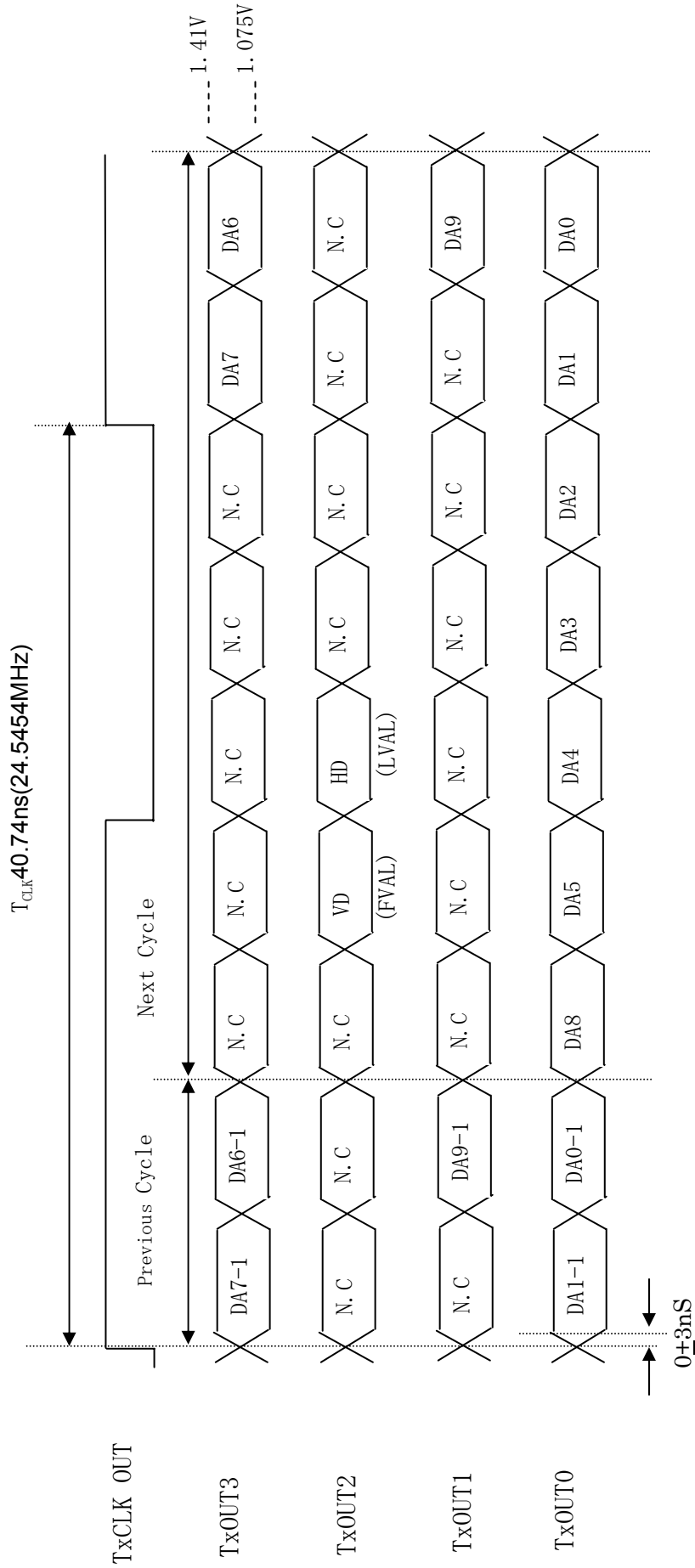

DWN			
DSGN	.	.	.
CHKD	.	.	.
APPD	.	.	.

KP-F30PCL  
Specifications

Hitachi Kokusai Electric

E400029541

Rev.

5/

DWN	/	.	.
DSGN		.	.
CHKD		.	.
APPD		.	.

KP-F30PCL Specifications

Hitachi Kokusai Electric

E400029541

Rev. / 6 /

(b) 8bit

$T_{CLK} 40.74ns(24.5454MHz)$

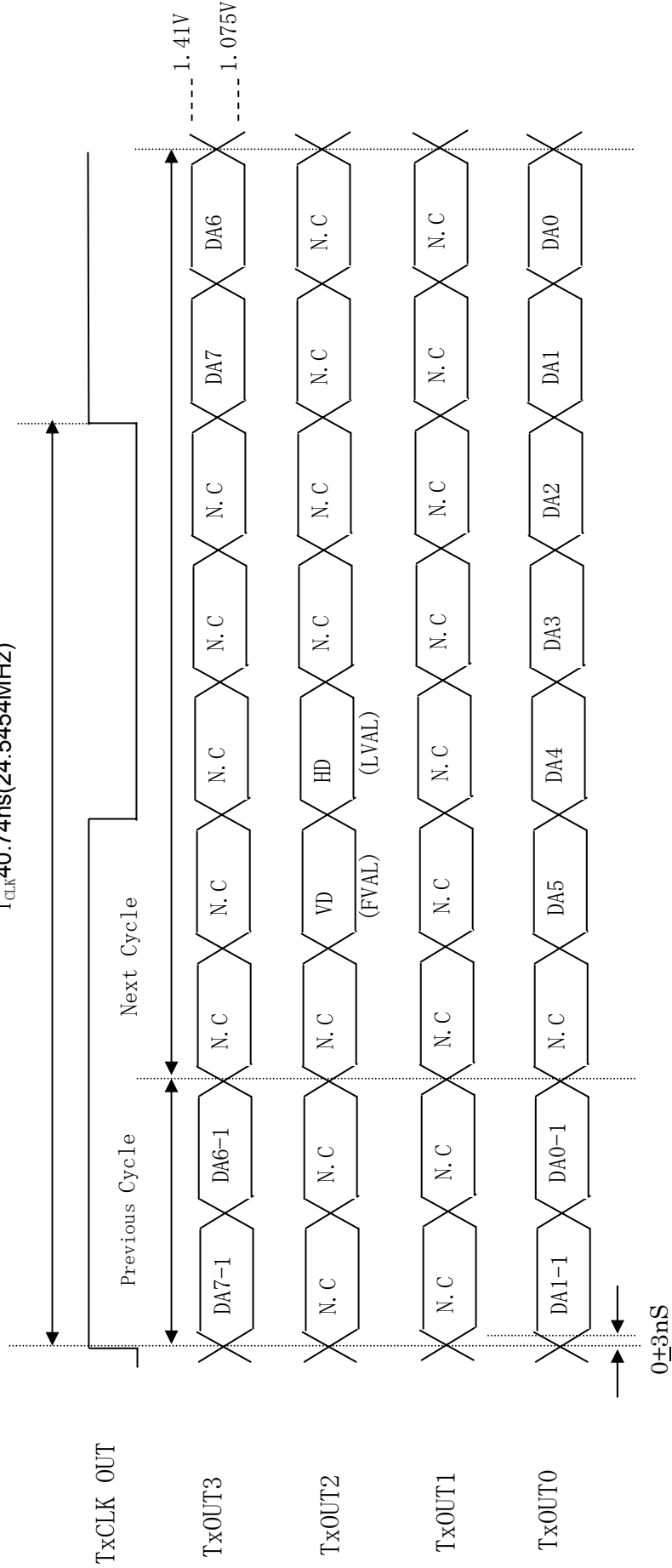

A B C D E F F

6-2 Output signal levels and timing

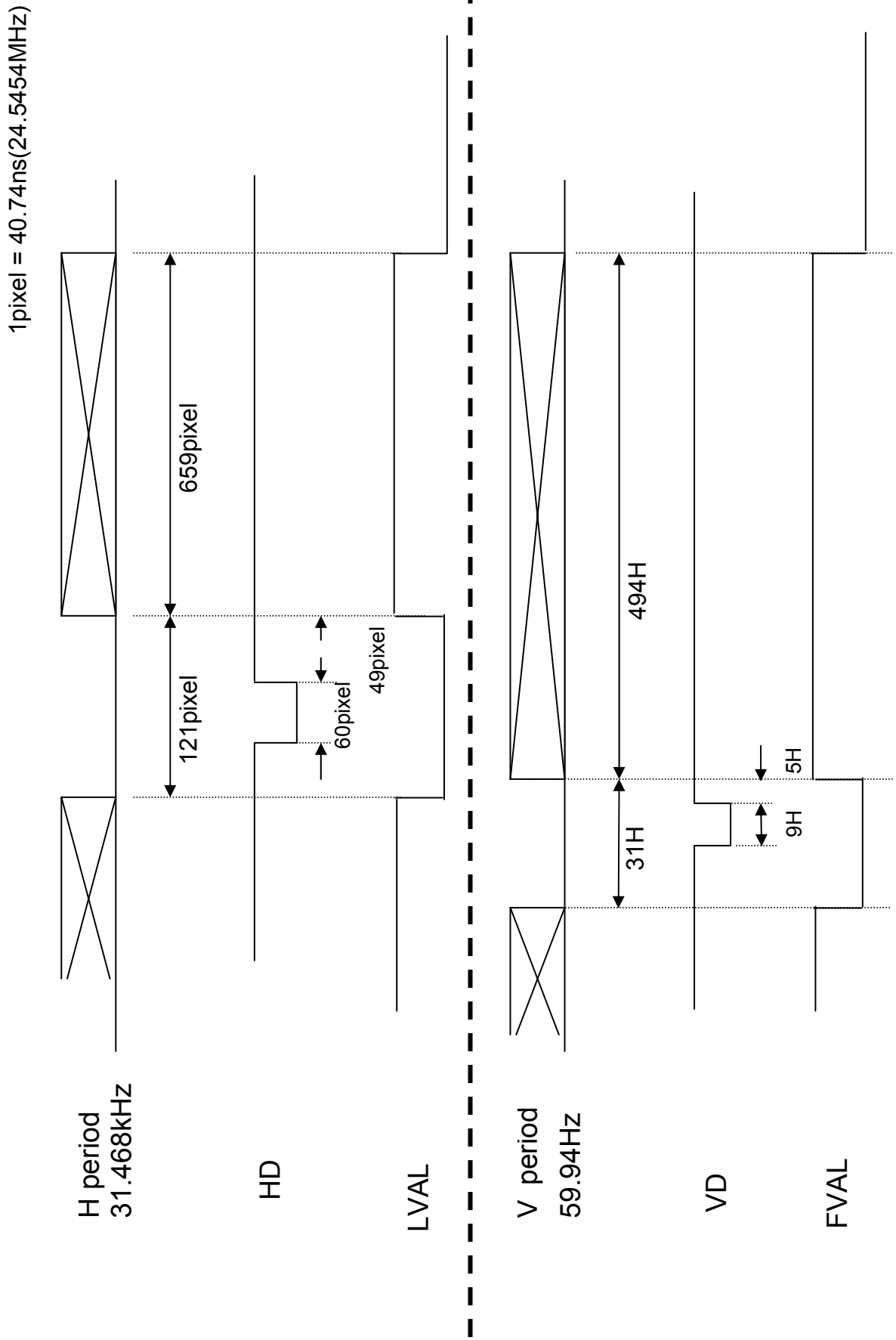

DWN	/	.	.
DSGN	/	.	.
CHKD	/	.	.
APPD	/	.	.

KP-F30PCL  
Specifications

Hitachi Kokusai Electric

**E400029541**  
Rev. / 7 /

A B C D E F

MODE TIMING CHART

6-3 ONE trigger mode

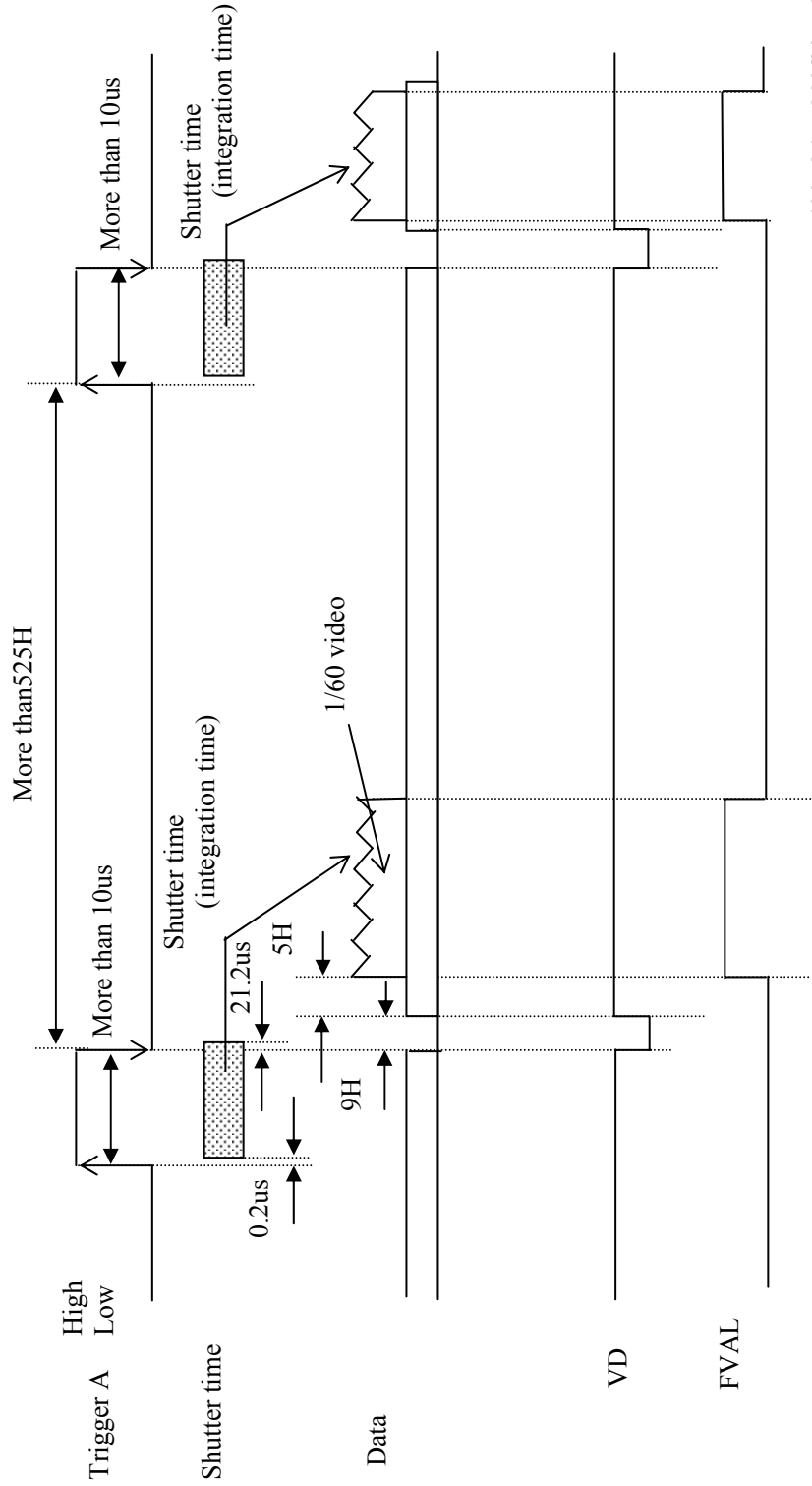

1H=31.468KHz=31.78us

Trigger polarity are selectable by remote control.  
(Factory setting: POS)

DWN	/	.	.
DSGN	/	.	.
CHKD	/	.	.
APPD	/	.	.

KP-F30PCL Specifications

Hitachi Kokusai Electric

E400029541

Rev. / 8 /

A B C D E F

6-4 Fixed shutter mode

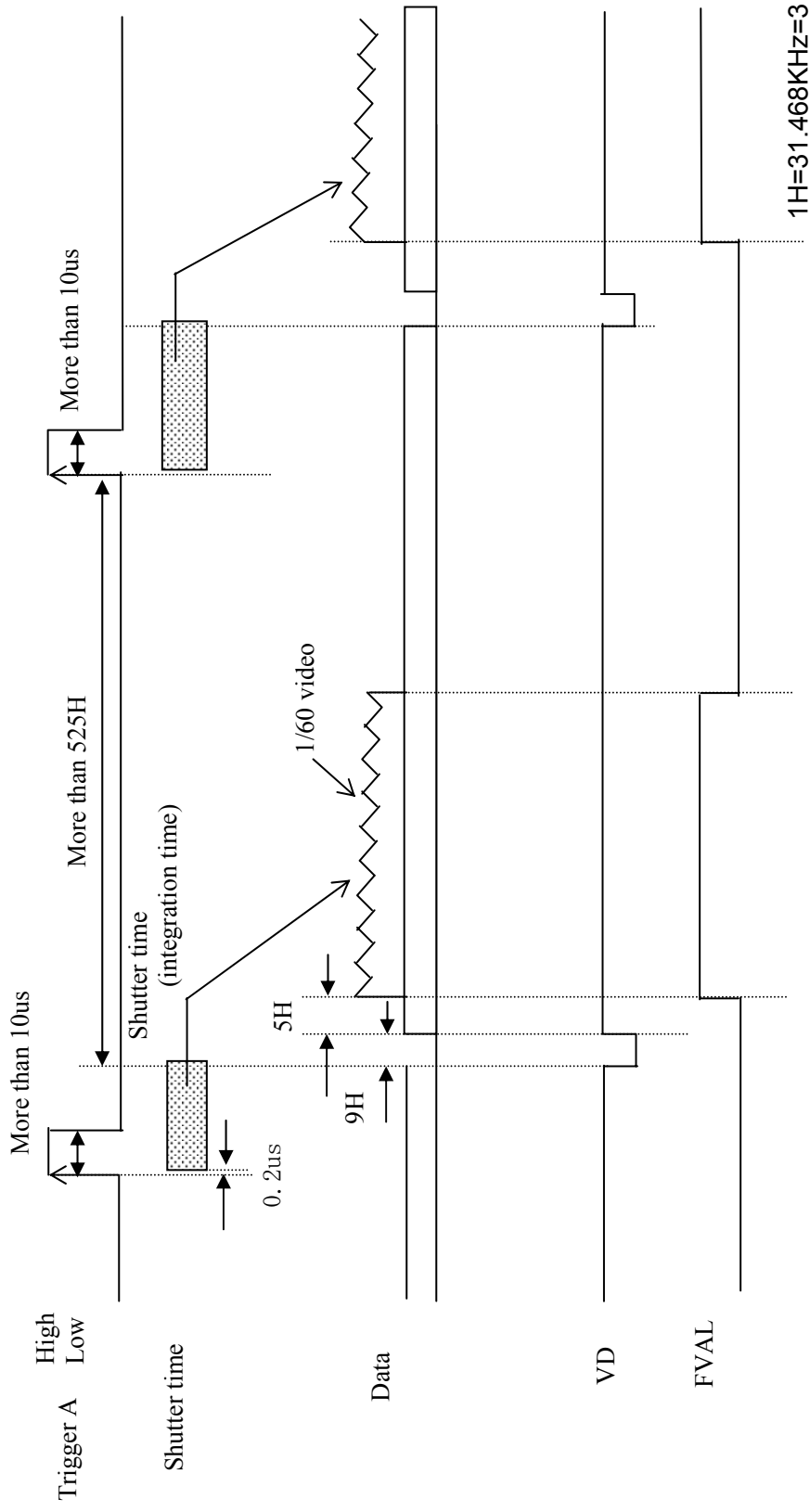

Trigger polarity are selectable by remote control.  
(Factory setting: POS)

DWN		.	.
DSGN		.	.
CHKD		.	.
APPD		.	.

KP-F30PCL  
Specifications

Hitachi Kokusai Electric

**E400029541**  
Rev.   9 /

A B C D E F

6-5 Reset control mode

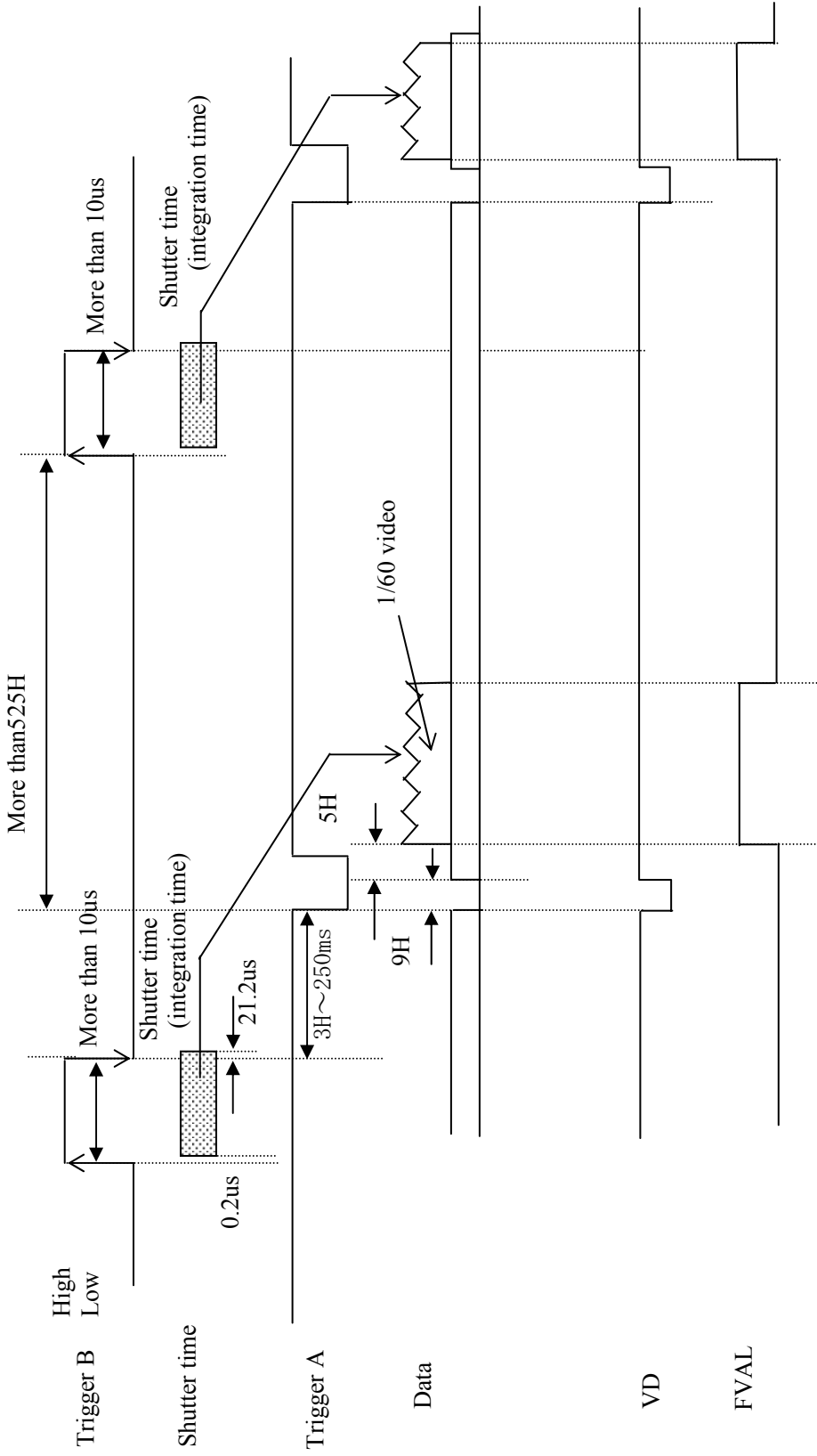

DWN		.	.
DSGN		.	.
CHKD		.	.
APPD		.	.

KP-F30PCL Specifications

Hitachi Kokusai Electric

E400029541

Rev. 10 /

Trigger polarity are selectable by remote control.  
(Factory setting: POS)

1 2 3 4

A B C D E F

Special function of reset control mode

The camera shifts to the output of a normal mode (continuous output) when Trigger B signal passes about 1/3 seconds in the state of High. It returns to the Trigger mode if Trigger B signal becomes Low. However, after becoming Low Trigger B, the period of 50ms becomes a Trigger signal input prohibition period.

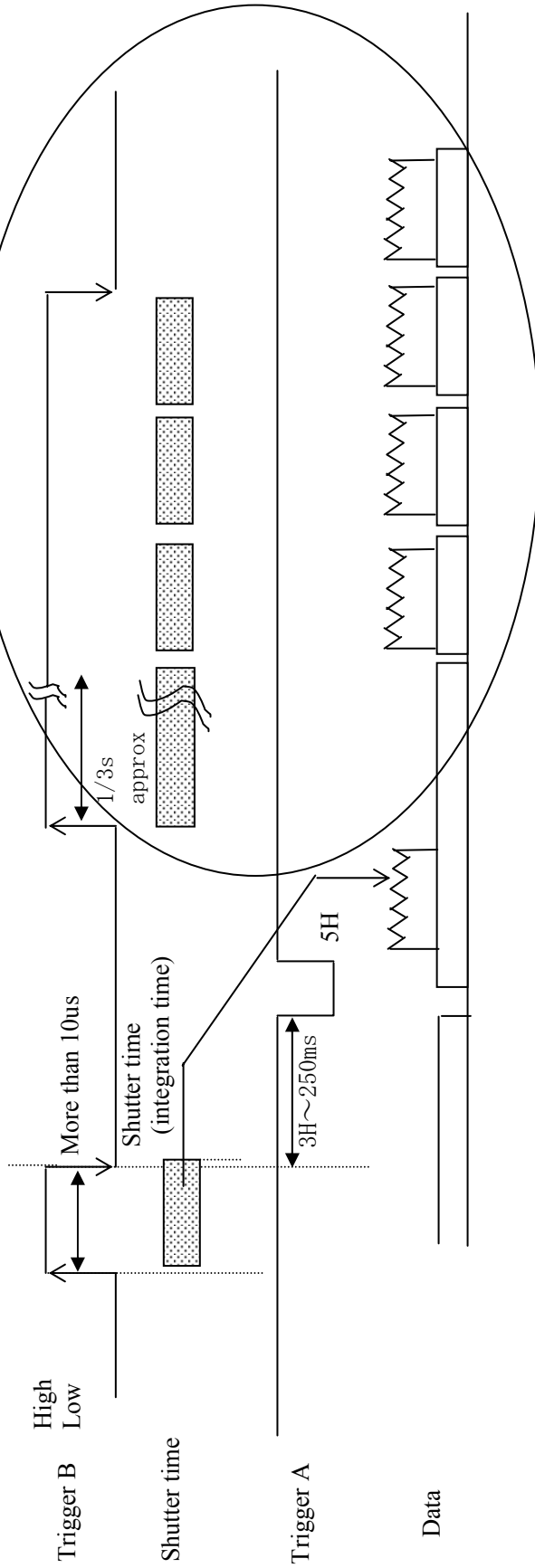

DWN				
DSGN				
CHKD				
APPD				

KP-F30PCL Specifications

Hitachi Kokusai Electric

E400029541

Rev. 11 /

6-6 Partial Scan NORMAL mode

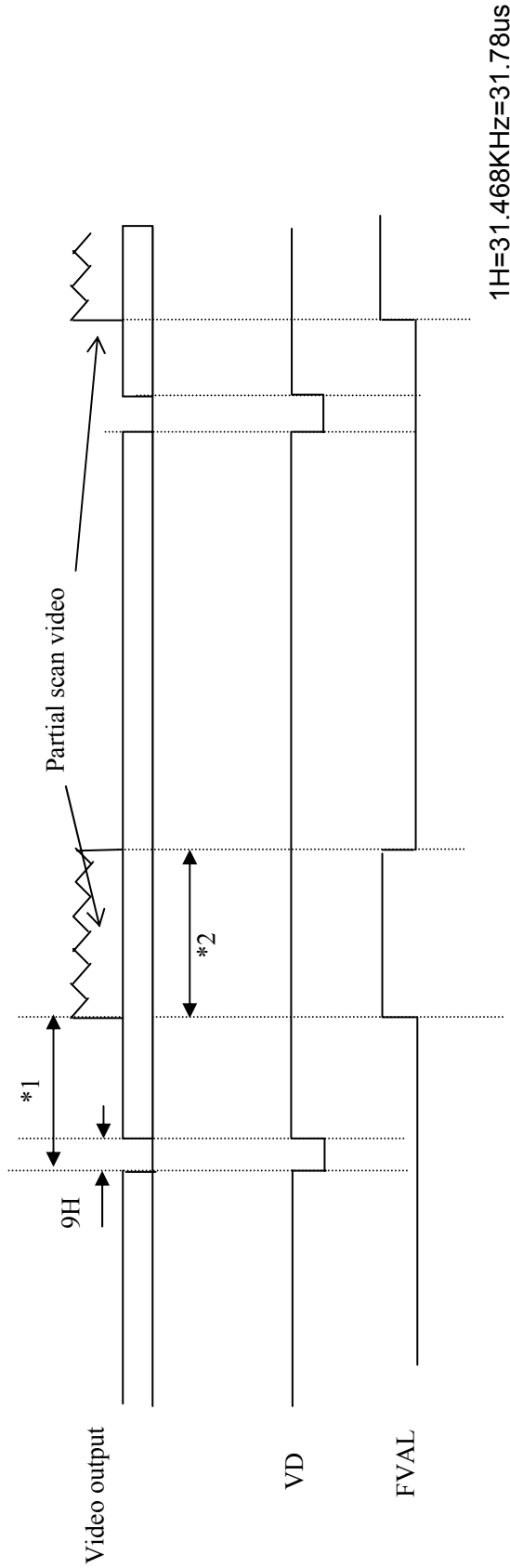

\*1: Variable by start position of picture grabbing

\*2: Selectable start position and width of picture grabbing from 1H to 494H by 1H step.  
Frame rate will not be changed by difference in start position of picture grabbing.

Note1: Cannot use the partial scan in following condition.

Start position of picture grabbing + Width of picture grabbing  $\geq$  494H

Note2: Please use FVAL in the partial scan.

DWN		.	.
DSGN		.	.
CHKD		.	.
APPD		.	.

KP-F30PCL Specifications

Hitachi Kokusai Electric

E400029541

Rev.

12 /

Graph following shows frame rate in each width of picture grabbing

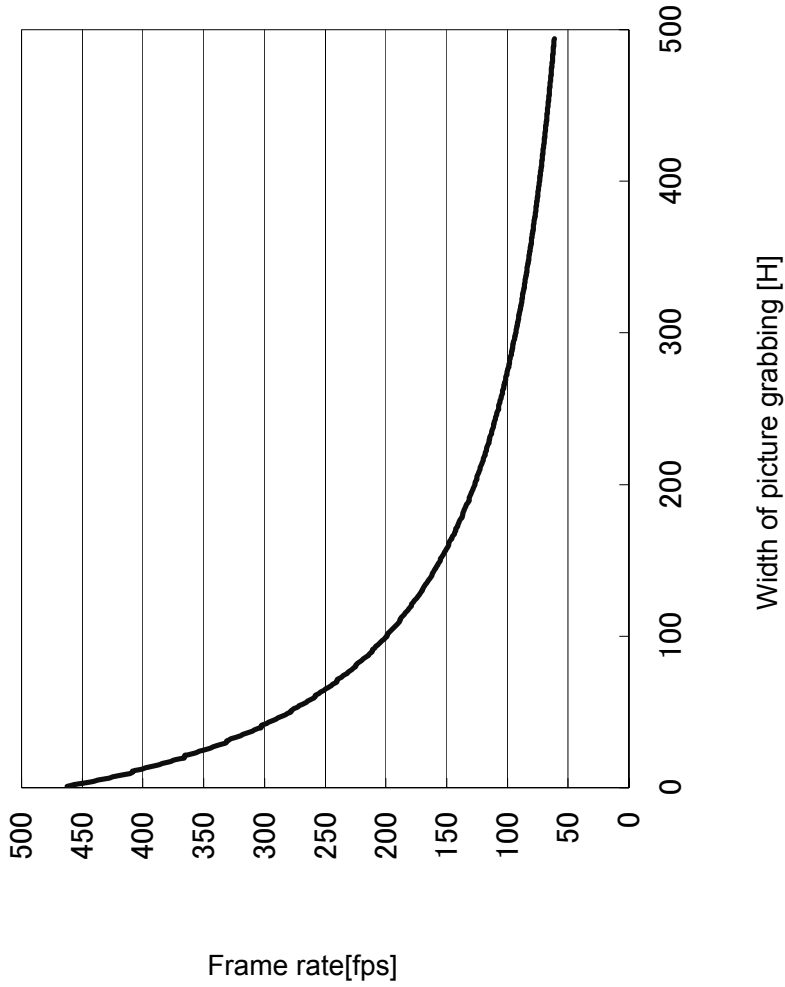

Note: Please ask your sales representative more detail information about frame rate in each width of picture grabbing

DWN	/	.	.
DSGN		.	.
CHKD		.	.
APPD		.	.

KP-F30PCL Specifications

Hitachi Kokusai Electric

**E400029541**

Rev. / 13 /

6-7 Partial Scan ONE Trigger mode

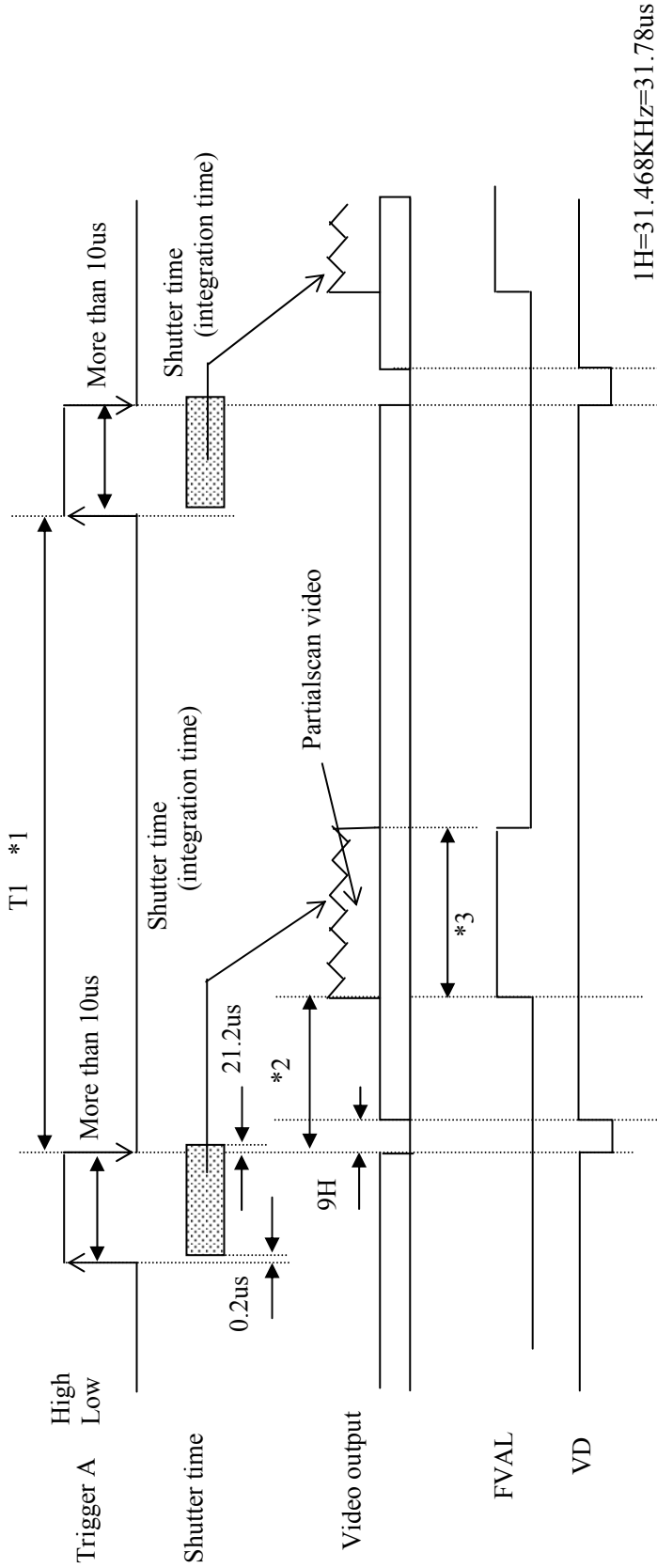

\*1: Please set X to be following condition  
 $X < T1 < 16.7ms$

X: Variable by width of picture grabbing(Refer to chart written in left side)

\*2: Variable by start position of picture grabbing

\*3: Selectable start position and width of picture grabbing from 1H to 494H by 1H step.

Note1: Cannot use the partial scan in following condition.  
 Start position of picture grabbing + Width of picture grabbing  $\geq 494H$

Note2: Please use FVAL in the partial scan.  
 Trigger polarity are selectable by remote control. (Factory setting: POS)

Example

Width of picture grabbing[H]	X(Minimum of T1)[ms]
1H	2.2
100H	5.1
200H	7.9
400H	13.7

DWN	/	.	.
DSGN	/	.	.
CHKD	/	.	.
APPD	/	.	.

KP-F30PCL Specifications

Hitachi Kokusai Electric

E400029541

Rev. 14 /



# External view

- MASS : APPROX 50 <sub>mg</sub>
- COLOR: BLACK
- TOLERANCE : ±0.5
- UNIT : mm

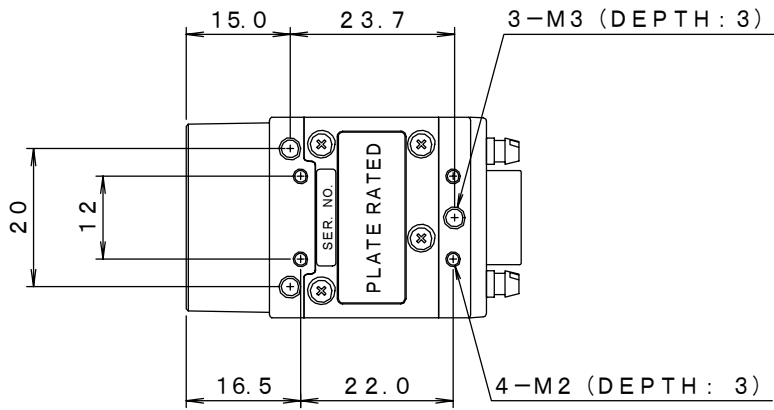
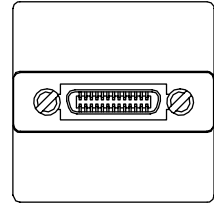
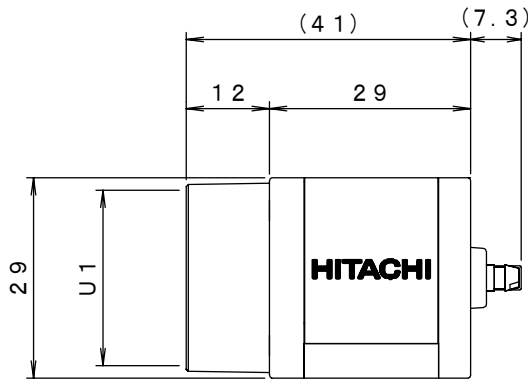
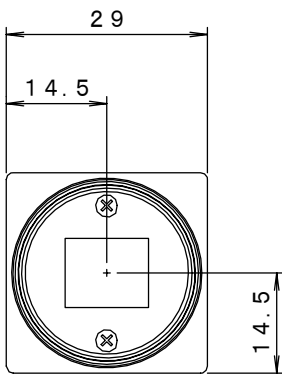
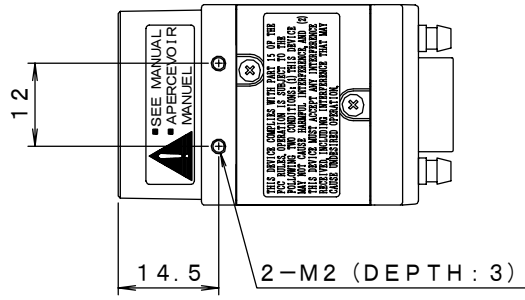

E400029541 16/

DWN		.	.
DSGN		.	.
CHKD		.	.
APPD		.	.

KP-F30PCL  
Specifications

Hitachi Kokusai Electric

E400029541

Rev. 16/

Notice:

These specifications are subject to change without prior notice due to product improvement.

Confirm the most recent specifications at time of order.

Hitachi Kokusai certifies this product complies with the standard warranty conditions of Hitachi Kokusai, and that quality control is implemented to the extent required to comply with these conditions.

RoHS Compliant

This product complies with the requirement of the RoHS(Restriction of the use of Certain Hazardous Substances in Electrical and Electronic Equipment) Directive 2002/95/EC

Warranty and service:

- (1) The guarantee period is one year after the data purchase.  
However, the defects due to erroneous use or intentional act are excluded.
- (2) As the defect after expiration of the guarantee period, where product repair is possible, repair will be performed at charge. .
- (3) The present Warranty pertains only to the camera unit. Secondary malfunctions attributable to camera failure as well as expenses incurred by disassembly and reassembly of the related system, are beyond the scope of this Warranty.
- (4) Compensation for loss of business, loss or damage to software, database and other contingent losses are beyond the scope of this Warranty.
- (5) Hitachi Kokusai Electric Inc. is not liable for the losses caused when the equipment is used in a system, use for business trades, production process, medical fields, crime prevention applications, etc.
- (6) When the stable operation is required for a long time, it is recommended to perform periodical maintenance and inspection every year or every two years.
- (7) In the case of camera trouble by miss wiring of cable, it will be considered as out of warranty.

E400029541 17/

DWN	KP-F30PCL Specifications	Hitachi Kokusai Electric	<b>E400029541</b>	
DSGN			Rev.	17 /
CHKD				
APPD				

