

# Gigabit Ethernet Progressive scan CCD camera KP-F500GV Specifications (Preliminary) Ver.1.00

## 1. General

The KP-F500GV is single CCD type camera which utilized the progressive scan CCD image sensor with square pixel for VGA format of 2/3-inch.

By adoption of Gigabit Ethernet interface, high-speed connection of maximum of 1 Gbps can be possible. Moreover, by using hub or switcher, construction of multiple camera system can be easily performed.

## 2. Outstanding features

### (1) High resolution

The 2/3-inch 5,050,000 pixels square lattice progressive scan CCD achieve a high resolution of 2456(H) x 2058(V).

### (2) Gigabit Ethernet interface

High-speed serial interface Gigabit Ethernet is supported and direct connection is possible to PC by the diameter cable of thin as compared with parallel output. It is possible to 100m.

### (3) GigE Vision (Ver 1.00) correspondence

Based on Industrial camera interface standard GigE Vision, a maximum of 1Gbps high speed data transmit is available and suitable for image processing.

### (4) GENiCAM (Ver. 1.00) correspondence

Development of camera control system is easy because industrial camera control API "GENiCAM" lead EMVA (European Machine Vision Association).

### (5) PoE correspondence

Power supply can be input via Ethernet cable (Power over Ethernet).

### (6) Remote control

- Multi-step electronic shutter (from 1/16 to 1/50000 second in 8 steps)
- Variable shutter (from 10 to 1/100000 second)
- The image capture at desired timing using the external trigger signal and other various functions are set by remote control via a Gigabit Ethernet cable.

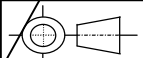
-	May.31,2008	(first edition)						
SYMBOL	DATE	DESCRIPTION					(DRAWN)	DESIGNED
MODEL KP-F500GV				TOLERANCE	Prod. Code - Order No.			
DESIGNED	DATE	APPROVED	DATE	UNIT	TITLE			REV.
CHECKED	DATE	STORED	DATE		KP-F500GV			0
Hitachi Kokusai Electric					SCALE	Specifications		
					DWG. No.			1 / 9

### 3. Specifications

A	(1) Imaging device	2/3-inch progressive scan interline CCD	A
	Total pixels	2536 (H) x 2068 (V)	
	Effective pixels	2456 (H) x 2058 (V)	
	Pixel size	3.45 um (H) x 3.45 um (V) (square lattice)	
	(2) Scanning area	8.47 mm (H) x 7.10 mm (V)	
	(3) Scanning system	Progressive	
	(4) Aspect ratio	5 : 4	
B	(5) Frame rate	16 frames per second (full pixel readout)	B
	(6) Sync system	Internal / external	
	(7) Lens mount	C mount	
	(8) Flange focal distance	17.526 mm	
	(9) Video output		
	Interface	Gigabit Ethernet	
	Protocol	GigE Vision compliant	
	Transfer	1 Gbit per second	
C	Image format	Mono 8/10/12bit	C
	Maximum image size	2448 (H) x 2050 (V)	
	Frame rate	16 frame per second	
		*Frame rate is different for following format	
		Mono 10/12bit: 11 frame per second	
	(10) Sensitivity	400lx, F5.6, 3200K	
	(11) Minimum illumination	1 lx (F1.4 GAIN MAX)	
D	(12) Electric shutter	OFF / Auto (AES) / Manual (PRESET or VARIABLE)	D
		OFF is normal exposure (frame rate)	
	PRESET	1/16, 1/60, 1/100, 1/250, 1/1000, 1/2000, 1/10000, 1/50000 second.	
	VARIABLE	10 to 1/100000 second	
	(13) External trigger shutter		
	Mode	Fixed shutter	
E		One trigger	E
		VD Sync	
		Reset control	
	Input	Via Gigabit Ethernet cable (Software trigger)	
		12-pin connector (dware trigger)	
	Input level	24Vp-p +/- 1V	
	Threshold	3.7V +/- 0.5V (Low --> High)	
		3.5V +/- 0.5V (High --> Low)	
F	Input polarity	High / Low adjustable	F
	Input delay	Adjustable	



#### 4. Composition

- (1) Camera (with IR cut filter)
- (2) CD-ROM (Operation manual, Control software and SDK)
- (3) Composition table

#### 5. Optional accessories

- (1) Dummy glass (AR coated)           ARC1214
- (2) IR cut filter                            IRC650
- (3) Junction box                            JU-F30,
- (4) Tripod adaptor                        TA-M1
- (5) 12pin plug                             HR10A-10P-12S(01)
- (6) Camera cable

	Molded type	Shield type
2 m	C-201KSM	C-201KSS
5 m	C-501KSM	C-501KSS
10 m	C-102KSM	C-102KSS

In the CE Marking region, use the shield type and install clamp filter (ZCAT2035-0930A: TDK) at both ends of the cable.

- (7) LAN cable (Commercial item)      CAT5E Straight cable
- CAT5E Cross cable
- CAT6 Straight cable
- CAT6 Cross cable

## 6. Specification of Digital output connector

### (1) Gigabit Ethernet connector

PIN NO.	Signal
1	TRP1+
2	TPR1-
3	TRP2+
4	TPR3+
5	TRP3-
6	TRP2-
7	TRP4+
8	TRP4-

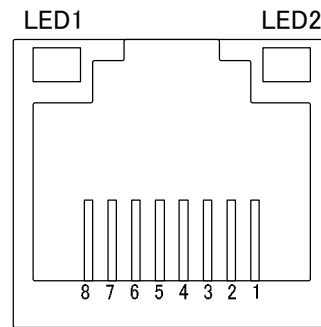

Connector: RJ-45

\*LED Status

STATUS	LED1(Green)	LED2 (Yellow)
Power ON	Light Off	Light On
Transmission	Blink On	Light On
Transmission pause	Light Off	Light On

### (2) 12-pin connector

PIN NO.	Signal	PIN NO.	Signal
1	GND (+12V)	7	TRIG-A / VD (H)
2	+12V	8	TRIG-B (C)
3	GND	9	TRIG-B (H)
4	AUX	10	FLASH / VD OUT
5	GND	11	N.C.
6	N.C.	12	TRIG-A / VD (C)

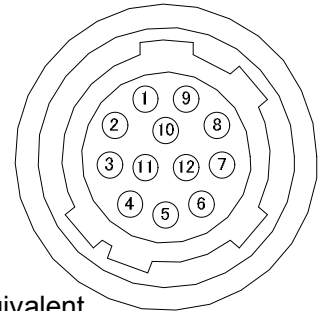

Connector (camera side) : SAMWOO SNH-10-12 (RPCB) or equivalent

Plug (matching cable plug) : Hirose HR10A-10P-12S (01) or equivalent

Please do not unplug and insert cable (camera cable) with a power supplied to a camera. Install clamp filter (ZCAT 2035-0930A: TDK) at both ends (camera and video processor ends) in the CE marking legion.

Please do not connect 1 pin and 3/5 pin when using PoE. When connecting it, PoE may stop the power supply. Because TRIG-A/VD and TRIG-B are photo coupler input, 8/12 pin is isolated with 1/3/5 pin. When 8/12 pin is connected to GND, please connect to 3 pin or 5 pin.

Note: Please do not input any signal to N.C. pin because machine may break down.

9. Spectral response

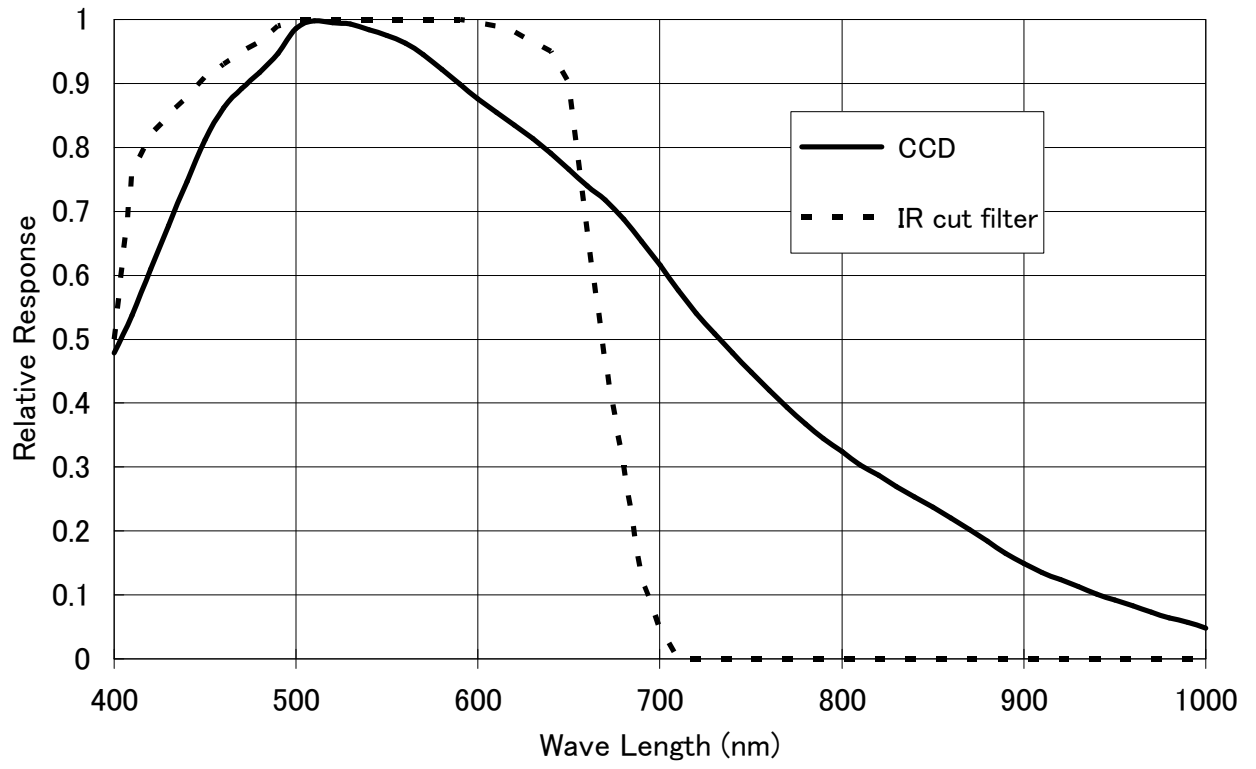

10. External view

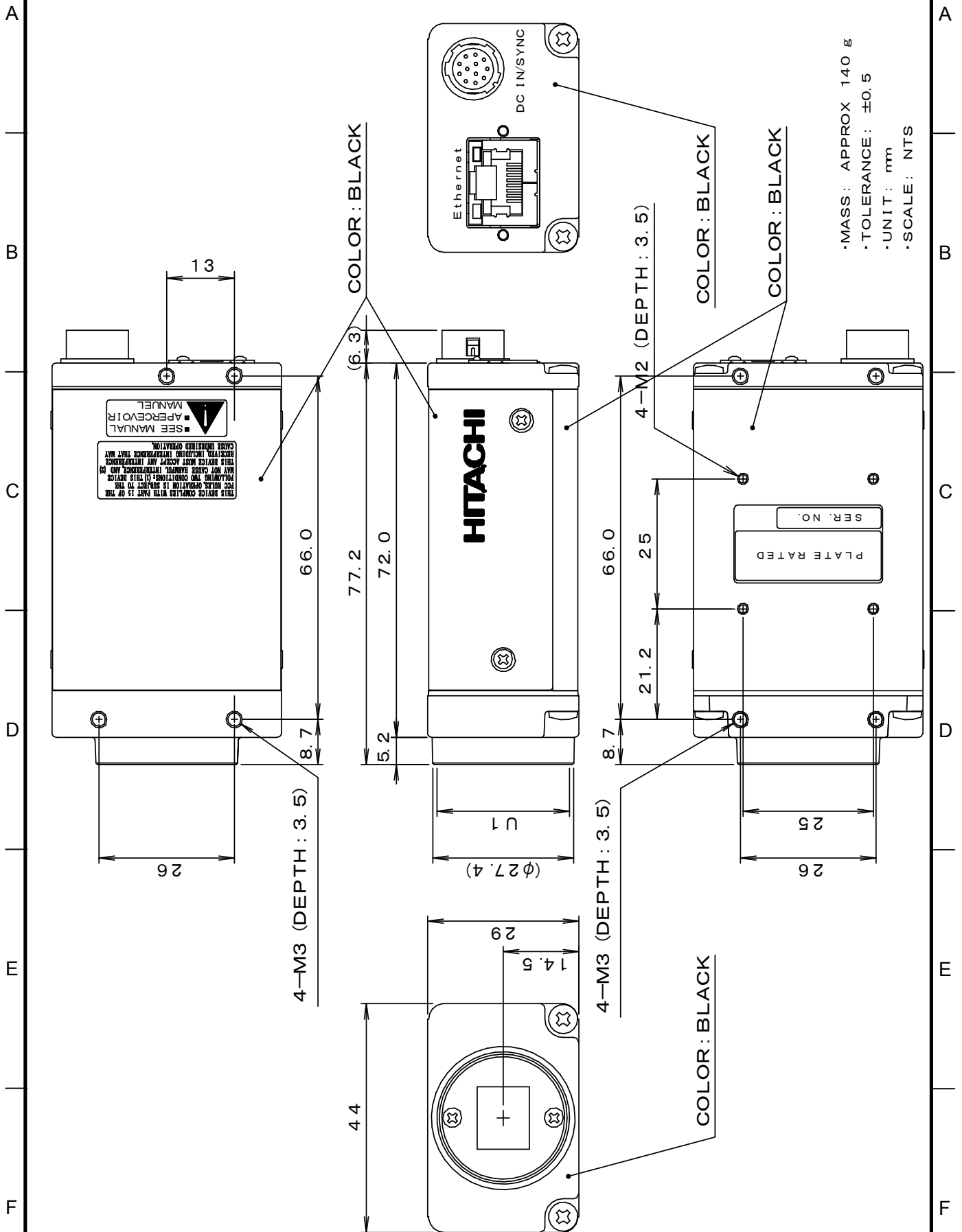

·MASS: APPROX 140 g  
 ·TOLERANCE:  $\pm 0.5$   
 ·UNIT: mm  
 ·SCALE: NTS

**Notice:**

These specifications are subject to change without prior notice due to product improvement.

Confirm the most recent specifications at time of order.

Hitachi Kokusai certifies this product complies with the standard warranty conditions of Hitachi Kokusai, and that quality control is implemented to the extent required to comply with these conditions.

**RoHS Compliant**

This product complies with the requirement of the RoHS(Restriction of the use of Certain Hazardous Substances in Electrical and Electronic Equipment) Directive 2002/95/EC

**Warranty and service:**

- (1) The guarantee period is one year after the data purchase.  
However, the defects due to erroneous use or intentional act are excluded.
- (2) As the defect after expiration of the guarantee period, where product repair is possible, repair will be performed at charge.
- (3) The present Warranty pertains only to the camera unit. Secondary malfunctions attributable to camera failure as well as expenses incurred by disassembly and reassembly of the related system, are beyond the scope of this Warranty.
- (4) Compensation for loss of business, loss or damage to software, database and other contingent losses are beyond the scope of this Warranty.
- (5) Hitachi Kokusai Electric Inc. is not liable for the losses caused when the equipment is used in a system, use for business trades, production process, medical fields, crime prevention applications, etc.
- (6) In the case of camera trouble by miss wiring of cable, it will be considered as out of warranty.

