

High pixel CCD camera

KP-F500PCL/SCL KP-FR500PCL/SCL



Operation Manual

Thank you for purchase this fine Hitachi Kokusai Electric CCD camera.

Before using the camera, please read this operation manual carefully and keep this manual on file for ready reference in the future.

RoHS Compliant

These products comply with the requirement of the RoHS (Restriction of the use of Certain Hazardous Substances in Electrical and electronic Equipment) Directive 2002/95/EC.

Hitachi Kokusai Electric Inc.

Declaration of Conformity

Manufacturer's Name: Hitachi Kokusai Electric, Inc.
Manufacturer's Address: 4-14-1 Sotokanda, Chiyoda-ku,
Tokyo 101-8980, Japan

Representative(s) Address in the EU: Hitachi Kokusai Electric Europe GmbH
Weiskircher Straße 88,
Jügesheim D-63110 Rodgau, Germany

Hitachi Kokusai Electric U.K. Ltd.
Windsor House, Britannia Road,
Waltham Cross, Hertfordshire,
EN8 7NX United Kingdom

declares, that the product:

Product Name: CCD Camera
Model Number(s): KP-F500PCL, KP-F500SCL

conforms to the following Standards:

EMC: EN 61000-6-3/2001
EN 61000-6-1/2001

Supplementary Information:

"The product complies with the requirements of the Low Voltage Directive 73/23/EEC and the EMC Directive 89/336/EEC."

Signature:

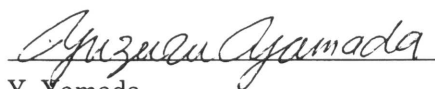

Y. Yamada
Senior Manager
Quality Assurance Department II
Hitachi Kokusai Electric Inc.

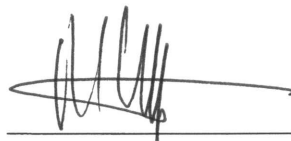

M. Katou
Managing Director
Hitachi Kokusai Electric Europe GmbH
Hitachi Kokusai Electric U.K. Ltd.

Date: 13th Feb.,2007

IMPORTANT SAFETY INSTRUCTIONS

1. Read Instructions

All the safety and operating instructions should be read before the product is operated.

2. Retain Instructions

The safety and operating instructions should be retained for future reference.

3. Heed Warnings

All warnings on the product and the operating instructions should be adhered to.

4. Follow Instructions

All operating and use instructions should be followed.

5. Cleaning

Unplug this product from the wall outlet before cleaning. Do not use liquid cleaners or aerosol cleaners. Use a damp cloth for cleaning.

6. Attachments

Do not use attachments not recommended by the product manufacturer as they may cause hazards.

7. Water and Moisture

Do not use this product near water - for example, near a bath tub, wash bowl, kitchen sink, or laundry tub; in a wet basement; or near a swimming pool; and the like.

8. Accessories

Do not place this product on an unstable cart, stand, tripod, bracket, or table. The product may fall, causing serious injury to a child or adult, and serious damage to the product. Use only with a cart, stand, tripod, bracket, or table recommended by the manufacturer, or sold with the product. Any mounting of the product should follow the manufacturer's instructions, and should use a mounting accessory recommended by the manufacturer.

9. Moving

A product and cart combination should be moved with care.

Quick stops, excessive force, and uneven surfaces may cause the product and cart combination to overturn.

10. Ventilation

Slots and openings in the cabinet are provided for ventilation and to ensure reliable operation of the product and to protect it from overheating, and these openings must not be blocked or covered.

The openings should never be blocked by placing the product on a bed, sofa, rug, or other similar surface. This product should not be placed in a built-in installation such as a bookcase or rack unless proper ventilation is provided or the manufacturer's instructions have been adhered to.

11. Power Sources

This product should be operated only from the type of power source indicated on the marking label. If you are not sure of the type of power supply to your home, consult your product dealer or local power company. For products intended to operate from battery power, or other sources, refer to the operating instructions.

12. Grounding or Polarization

This product is equipped with a three-wire grounding-type plug a plug having a third (grounding) pin. This plug will only fit into a grounding-type power outlet. This is a safety feature. If you are unable to insert the plug into the outlet, contact your electrician to replace your obsolete outlet. Do not defeat the safety purpose of the grounding-type plug.

13. Power-Cord Protection

Power-supply cords should be routed so that they are not likely to be walked on or pinched by items placed upon or against them, paying particular attention to cords at plug, convenience receptacles, and the point where they exit from the product.

14. Lightning

For added protection for this product during a lightning storm, or when it is left unattended and unused for long periods of time, unplug it from the wall outlet. This will prevent damage to the product due to lightning and power-line surges.

15. Overloading

Do not overload wall outlets, extension cords or integral convenience receptacles as this can result in a risk of fire or electric shock.

16. Object and Liquid Entry

Never push objects of any kind into this product through openings as they may touch dangerous voltage points or short-out parts that could result in a fire or electric shock. Never spill liquid of any kind on the product.

17. Inflammable and Explosive Substance

Avoid using this product where there are gases, and also where there are inflammable and explosive substances in the immediate vicinity.

18. Heavy Shock or Vibration

When carrying this product around, do not subject the product to heavy shock or vibration.

19. Servicing

Do not attempt to service this product yourself as opening or removing covers may expose you to dangerous voltage or other hazards. Refer all servicing to qualified service personnel.

20. Damage Requiring Service

Unplug this product from the wall outlet and refer servicing to qualified service personnel under the following conditions:

- a. When the power-supply cord or plug is damaged.
- b. If liquid has been spilled, or objects have fallen into the product.
- c. If the product has been exposed to rain or water.
- d. If the product does not operate normally by following the operating instructions. Adjust only those controls that are covered by the operating instructions as an improper adjustment of other controls may result in damage and will often require extensive work by a qualified technician to restore the product to its normal operation.
- e. If the product has been dropped or damaged in any way.
- f. When the product exhibits a distinct change in performance-this indicates a need for service.

21. Replacement Parts

When replacement parts are required, be sure the service technician has used replacement parts specified by the manufacturer or have the same characteristics as the original part.

Unauthorized substitutions may result in fire, electric shock, or other hazards.

22. Safety Check

Upon completion of any service or repairs to this product, ask the service technician to perform safety checks to determine that the product is in proper operating condition.

23. Wall or Ceiling Mounting

The product should be mounted to a wall or ceiling only as recommended by the manufacturer.

24. Heat

The product should be situated away from heat sources such as radiators, heat registers, stoves, or other products (including amplifiers) that produce heat.

WICHTIGE SICHERHEITS ANWEISUNGEN

1. Alle Anweisungen lesen

Vor Betrieb des Erzeugnisses sollten alle Sicherheits- und Bedienungsanleitungen gelesen werden.

2. Die Anweisungen aufbewahren

Die Sicherheits- und Bedienungsanleitungen sollten fünftigen Bezug aufbewahrt werden.

3. Warnungen beachten

Die Warnungen auf dem Erzeugnis und in den Bedienungsanleitungen sollten beachtet werden.

4. Anweisungen befolgen

Alle Bedienungsanleitung- und Verwendungsanweisungen sollten befolgt werden.

5. Reinigung

Den Stecker des Geräts vor Reinigung aus der Steckdose ziehen. Keine flüssigen Reinigungsmittel oder Aerosolreiniger verwenden. Zum Reinigen einen feuchten Lappen verwenden.

6. Zubehör

Nur vom-Hersteller des Erzeugnisses empfohlenes Zubehör verwenden, da es sonst zu Störungen kommen kann.

7. Wasser und Feuchtigkeit

Dieses Erzeugnis nicht in der Nähe von Wasser verwenden - z.B. in der Nähe einer Badewanne, eines Waschbeckens, einer Küchenspüle, eines Waschzubers, in einem nassen Keller, in der Nähe eines Schwimmbeckens usw.

8. Aufstellung

Das Erzeugnis nicht auf einen unstabilen Wagen, Stand, Dreifuß, Träger oder Tisch stellen.

Das Erzeugnis kann sonst herunterfallen und ein Kind oder einen Erwachsenen schwer verletzen.

Außerdem kann das Gerät schwer beschädigt werden. Nur mit einem Wagen, Stand, Dreifuß, Träger oder Tisch verwenden, der vom Hersteller empfohlen oder mit dem Erzeugnis verkauft worden ist. Für jegliche Anbringung sollten die Anweisungen des Herstellers befolgt werden, und das vom Hersteller empfohlene Anbringungszubehör sollte verwendet werden.

9. Eine Kombination von Erzeugnis und Wagen sollte vorsichtig bewegt werden

Schneller Halt, übermäßige Krafteinwirkung und unebene Oberflächen können Umkippen der Kombination von Erzeugnis und Wagen verursachen.

10. Ventilation

Schlitze und Öffnungen im Gehäuse dienen der Ventilation. Sie sind für zuverlässigen Betrieb des Gerätes und Schutz vor Überhitzung erforderlich und dürfen nicht blockiert oder abgedeckt werden. Die Öffnungen sollten niemals dadurch blockiert werden, daß, das Gerät auf ein Bett, ein Sofa, einen Teppich oder eine ähnliche Oberfläche gestellt wird.

Das Gerät sollte nur dann in Einbauinstallation wie in einem Bücherschrank oder einem Gestell verwendet werden, wenn angemessene Ventilation vorgesehen ist bzw. Die Anweisungen des Herstellers befolgt worden sind.

11. Stromversorgung

Dieses Erzeugnis sollte nur an der auf dem Typenschild angegebenen Stromversorgungsart betrieben werden. Wenn Sie nicht sicher sind, was für eine Stromversorgung Sie haben, so wenden Sie sich bitte an Ihren Erzeugnishändler oder an das lokale Elektrizitätswerk. Beziehen Sie sich für Batteriebetrieb oder andere Stromquellen vorgesehene Erzeugnisse bitte auf die Bedienungsanleitungen.

12. Erdung oder Polarisierung

Dieses Erzeugnis ist mit einem Schutzkontaktstecker mit drei Leitern ausgerüstet, mit einem Erdungskontakt. Dieser Stecker paßt nur in ein schuko-Steckdose. Dies ist eine Sicherheitsmaßnahme. Wenn Sie den Stecker nicht in die Steckdose stecken können, so wenden Sie sich bitte an ihren Elektriker, damit er die veraltete Schutz des Schutzkontaktsteckers unwirksam.

13. Netzkabelschutz

Netzkabel sollten so verlegt werden, daß möglichst nicht darauf getreten wird und daß sie nicht eingeklemmt werden, mit besonderer Beachtung der Kabel an Stackern, Verlängerungskabeln und dem Austritt des Kabels aus dem Erzeugnis.

14. Blitzschlag

Für zusätzlichen Schutz des Erzeugnisses während eines Gewitters oder bei Nichtverwendung für lange Zeit den Stecker aus der Steckdose ziehen. Dies verhindert Beschädigung durch Blitzschlag und Netzspannungsschläge.

15. Überlastung

Wandsteckdosen, Verlängerungskabel und eingebaute Bequemlichkeitssteckdosen nicht überlasten, da dies Feuer oder elektrischen Schlag verursachen kann.

16. Eindringen von Fremdkörpern und Flüssigkeit

Niemals Objekte irgendwelcher Art durch die Öffnungen in das Gerät schieben, da diese unter hoher Spannung stehende Teile berühren oder kurzschließen können, wodurch es zu Feuer oder elektrischem Schlag kommen kann. Niemals Flüssigkeiten irgendwelcher Art auf das Erzeugnis verschütten.

17. Entflammare und explosive Substanzen

Vermeiden Sie Verwendung dieses Erzeugnisses an Orten mit Gasen bzw. entflammaren oder explosiven Substanzen in der direkten Umgebung.

18. Starke stöße oder Vibrationen

Setzen Sie das Erzeugnis beim Transport nicht starken Stößen oder Vibrationen aus.

19. Wartung

Versuchen Sie nicht, dieses Erzeugnis Selbst zu warten, da Sie sich durch Öffnen bzw. Entfernen von Abdeckungen hohen Spannungen und sonstigen Gefährdungen aussetzen können.

Beziehen Sie sich für jegliche Wartung auf qualifiziertes Wartungspersonal.

20. Beschädigung, die Wartung erfordert

Ziehen Sie den Stecker dieses Erzeugnisses aus der Steckdose und wenden Sie sich an qualifiziertes Wartungspersonal, wenn eine der folgenden Bedingungen vorliegt:

- a. Wenn das Netzkabel oder der Stecker beschädigt ist.
- b. Bei Eindringen von Flüssigkeit oder Fremdkörpern in das Gerät.
- c. Wenn das Erzeugnis Regen oder Wasser ausgesetzt worden ist.
- d. Wenn das Erzeugnis bei Befolgen der Bedienungsanleitungen nicht normal funktioniert.

Nur die Regelelemente verstellen, die in den Bedienungsanleitungen behandelt werden, da unangemessene Einstellung anderer Regelelemente Beschädigung verursachen kann und oft beträchtliche Arbeit durch einen qualifizierten Techniker erfordert, um das Erzeugnis wieder, zu normalem Betrieb zurückzubringen.

- e. Wenn das Erzeugnis fallen gelassen oder beschädigt worden ist.
- f. Wenn das Erzeugnis eine klare Änderung in der Leistung zeigt-dies weist darauf hin, daß Wartung erforderlich ist.

21. Ersatzteile

Wenn Ersatzteile erforderlich sind, darauf achten, daß der Wartungstechniker nur die vom Hersteller festgelegten Ersatzteile oder Teile mit den gleichen Charakteristiken wie die ursprünglichen Teile verwendet. Unautorisierte Ersatzteile können Feuer, elektrischen Schlag oder sonstige Gefährdungen verursachen.

22. Sicherheitsprüfung

Bitten Sie den Wartungstechniker nach der Vollendung von Wartung oder Reparaturarbeiten an diesem Erzeugnis um die Durchführung von Sicherheitsprüfungen, um zu bestimmen, daß das Erzeugnis im angemessenen Betriebszustand ist.

23. Anbringung an der Wand oder an der Decke

Das Erzeugnis sollte nur entsprechend den Empfehlungen des Herstellers an einer Wand oder an der Decke angebracht werden.

24. Wärme

Das Erzeugnis sollte fern von Wärmequellen wie Radiatoren, Heizwiderständen, Öfen und anderen Wärme erzeugenden Erzeugnissen (einschließlich Verstärkern) aufgestellt werden.

MISES EN GARDE IMPORTANTES

1. Lire les instructions

Lire toutes les instructions de sécurité et de fonctionnement avant de faire fonctionner l'appareil.

2. Conserver ces instructions

Conserver les instructions de sécurité et de fonctionnement à des fins de référence ultérieure.

3. Tenir compte des avertissements

Tous les avertissements qui figurent sur l'appareil et dans le mode d'emploi devront être respectés.

4. Observer les instructions

Observer toutes les instructions de fonctionnement et d'utilisation.

5. Nettoyage

Avant de procéder au nettoyage, débrancher l'appareil de la prise secteur. Ne pas utiliser de produits de nettoyage liquides ou en aérosol.

Nettoyer l'appareil avec un chiffon humide.

6. Fixations

Ne pas utiliser de fixations non recommandées par le fabricant de l'appareil car elles pourraient être source de danger.

7. Eau et humidité

Ne pas utiliser l'appareil à proximité d'eau - par exemple près d'une baignoire, d'un lavabo, d'un évier ou d'un bac à lessive, dans un sous-sol humide, ou près d'une piscine, etc.

8. Accessoires

Ne pas placer l'appareil sur un chariot, un socle, un pied, un support ou une table instables. L'appareil pourrait tomber, blessant grièvement des enfants ou des adultes, et étant sérieusement endommagé.

Utiliser exclusivement le chariot, le socle, le pied, le support ou la table recommandés par le fabricant, ou vendus avec l'appareil. Pour tout montage de l'appareil, respecter les instructions du fabricant, et utiliser à cette fin l'accessoire de montage recommandé par le fabricant.

9. L'appareil monté sur son chariot devra être déplacé avec précaution

Des arrêts brusques, une force excessive et des surfaces irrégulières pourraient provoquer le renversement de l'ensemble appareil-chariot.

10. Ventilation

Les fentes et les ouvertures du coffret sont prévues pour la ventilation ainsi que pour garantir un fonctionnement en toute sécurité de l'appareil et le protéger de toute surchauffe, et ces ouvertures ne devront donc être ni obstruées ni recouvertes. Ne jamais obstruer les ouvertures en plaçant l'appareil

sur un lit, un sofa, un tapis ou toute surface similaire. Ne jamais placer l'appareil dans un support confiné, par exemple une bibliothèque ou une étagère, sans ventilation suffisante ou sans respecter les instructions du fabricant.

11. Sources d'alimentation

L'appareil devra être alimenté exclusivement sur le type d'alimentation indiqué sur l'étiquette signalétique. Si l'on n'est pas sûr du type d'alimentation du local, consulter le revendeur de l'appareil ou la compagnie d'électricité locale. Pour les appareils qui fonctionnent sur batterie ou sur d'autres sources, voir le mode d'emploi.

12. Mise à la terre ou polarisation

L'appareil est doté d'une fiche trifilaire avec mise à la terre, dont la troisième broche assure la mise à la terre. Cette fiche ne rentrera que dans les prises trifilaires de mise à la terre. Ceci est une mesure de sécurité. Si la fiche ne rentre pas dans la prise, faire remplacer la prise défectueuse par un électricien.

Ne pas rendre vaine la mesure de sécurité assurée par cette prise avec mise à la terre.

13. Protection du cordon d'alimentation

Acheminer les cordons d'alimentation de façon qu'on ne risque pas de marcher dessus ou de les coincer sous un objet placé dessus ou contre eux.

Faire particulièrement attention aux fiches des cordons, à la proximité des prises, et à l'endroit où ils ressortent de l'appareil.

14. Foudre

Pour renforcer la protection de l'appareil pendant un orage, ou si l'on s'en éloigne ou qu'on reste longtemps sans l'utiliser, le débrancher de la source d'alimentation. Ceci permettra d'éviter tout dommage de l'appareil dû à la foudre et aux surtensions de ligne.

15. Surcharge

Ne pas surcharger les prises, rallonges et prises multiples car cela pourrait entraîner un risque de feu ou de choc électrique.

16. Pénétration d'objets et de liquides

Ne jamais enfoncer d'objets d'aucune sorte dans les ouvertures de l'appareil car ils pourraient toucher des points de tension dangereuse ou court-circuiter des pièces, ce qui pourrait provoquer un feu ou un choc électrique. Ne jamais renverser de liquide d'aucune sorte sur l'appareil.

17. Substances inflammables et explosives

Éviter d'utiliser l'appareil en présence de gaz, ainsi qu'à proximité immédiate de substances inflammables et explosives.

18. Chocs ou vibrations violents

Lorsqu'on transporte l'appareil, ne pas le soumettre à des chocs ou des vibrations violents.

19. Réparations

Ne pas tenter de réparer l'appareil soi-même car le fait d'ouvrir ou de retirer les caches risque d'exposer l'utilisateur à des tensions dangereuses

notamment. Confier toute réparation à un personnel qualifié.

20. Dommages nécessitant réparations

Débrancher l'appareil de la source d'alimentation et confier les réparations à un personnel qualifié dans les cas suivants:

- a. Lorsque le cordon d'alimentation ou sa fiche sont endommagés
- b. Si du liquide s'est renversé sur l'appareil ou que des objets sont tombés dedans
- c. Si l'appareil a été exposé à la pluie ou à l'eau.
- d. Si l'appareil ne fonctionne pas normalement lorsqu'on observe les instructions d'utilisation.

Ne régler que les commandes couvertes par le mode d'emploi ; en effet, un réglage incorrect des autres commandes pourrait entraîner des dommages et nécessiteront souvent des travaux de réparation coûteux par un technicien qualifié pour remettre l'appareil en état de marche.

- e. Si l'appareil est tombé ou qu'il a été endommagé.
- f. Si l'appareil affiche une nette modification de ses performances, cela signifie qu'il a besoin d'être réparé.

21. Pièces de rechange

Si l'on a besoin de pièces de rechange, veiller à ce que le technicien de réparation utilise exclusivement les pièces de rechange spécifiées par le fabricant ou des pièces ayant les mêmes caractéristiques que les pièces d'origine. Les pièces de rechange non autorisées risquent de provoquer un feu, un choc électrique et autres dangers.

22. Vérification de sécurité

Après tout travail d'entretien ou de réparation de l'appareil, demander au technicien de réparation d'effectuer les vérifications de sécurité pour s'assurer que l'appareil est en bon état de marche.

23. Montage au mur ou au plafond

L'appareil ne pourra être monté au mur ou au plafond que de la manière recommandée par le fabricant.

24. Chaleur

Eloigner l'appareil des sources de chaleur, telles que radiateurs, appareils de chauffage, cuisinières, et de tout produit engendrant de la chaleur (y compris les amplificateurs).

IMPORTANT NOTICE

USA

These products have been tested and found to comply with the limits for a Class A digital device, pursuant to Part 15 of the FCC Rules. These limits are designed to provide reasonable protection against harmful interference when the equipment is operated in a commercial environment. This equipment generates, uses, and can radiate radio frequency energy and, if not installed and used in accordance with the instruction manual, may cause harmful interference to radio communications. Operation of this product in a residential area is likely to cause harmful interference in which case the user will be required to correct the interference at his own expense.

WARNING

Changes or modifications not expressly approved by Hitachi Denshi responsible for compliance could void the user's authority to operate the equipment.

For Canada

This product does not exceed the class A/class B limits for radio noise emissions from digital apparatus as set out in the radio interference regulations.

Le présent appareil n'émet pas de bruits radioélectriques dépassant les limites applicables aux appareils numériques de classe A prescrites dans le règlement sur le brouillage radioélectrique édicté par le ministère des communications du Canada.

Phenomena inherent to CCD imaging device

The following phenomena are inherent to a charge coupled device imaging element and do not indicate malfunction.

1) Smear and blooming

Vertical bands are visible when a strong light enters the scene. Adjust the camera aiming direction carefully to avoid strong direct or reflected light.

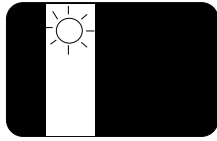

2) Fixed pattern noise

High ambient temperature can cause fixed pattern noise to appear throughout the scene.

3) Moire

Interaction between patterns can produce an additional "phantom" pattern to appear. The CCD picture elements (pixels) are arranged in a pattern, which can interact with a pattern in the scene (e.g., a performer wearing a finely striped necktie) to result in a Moire pattern. The effect should be considered when selecting costumes, props and other scene elements.

4) Ghosting

Strong direct or reflected light near an object of interest can cause ghosting of the object to appear in the picture. The effect is more obtrusive with certain iris settings and lens types. Select the scene layout and camera pointing direction carefully in order to avoid this effect.

Operating considerations Notes to users

1. Important safety notes

- Use this camera with a 12VDC power supply,
- Observe that flammable objects, water or metal do not enter the camera interior. These may lead to failure or accident.
- Do not modify the camera or use the camera with external covers removed. These may cause failure, void any warranties and pose a safety hazard.
- Stop using the camera at the approach of electrical storm (thunder audible). Protect the camera from rain if using it outdoors.
- In event the camera shows any abnormality, switch off the camera and disconnect the power cord. Contract a Hitachi Denshi service representative.

2. Handling

- Do not attempt to remove cover.
- When installing or removing a lens, be sure to use care that water or dust does not enter the inside of the camera.

3. Installing and storage

Avoid installing or storing the camera in the following environments.

- Environments exposed to direct sunlight, rain or snow.
- Environments where combustible or corrosive gas exists.
- Excessively warm or cold environment (Operating ambient temperature: -10 to 50°C).
- Humid or dusty environment.
- Place subjected to excessive vibration or shock.
- Environment exposed to strong electric or magnetic field.
- Do not aim the camera lens at the sun.
- Do not shoot strong light.

When such a scene is shot, vertical trailing will appear. However, this is not due to failure. In case strong light enters camera through the lens, partial deterioration in picture quality will result.

4. To obtain stable performance for long time

When the camera is used continuously for long time under high ambient temperature, the inside electrical parts become deteriorated, resulting in shortening its life. To use the camera continuously for long time, the highest temperature must be below 40°C .

5. Connectors

Confirm the power is off before connecting or disconnecting a signal cable. Grasp connectors by the body, not the attached wires.

6. Cleaning

- Use a blower or a lens brush to remove dusts on the lens or the optical filter.
- Wipe dirt on the case off with dry soft cloth. If dirt is hardened, wipe it off with cloth moistened with neutral detergent liquid; wipe the cover with dry cloth.
- Do not use benzene, thinner, alcohol, liquid cleaner or spray-type cleaner.
- In event dust or other debris is lodged between the CCD and optical filter, consult dealer for cleaning by an optical technician.

Table of Contents

1. Overview	1
2. Standard Composition	1
3. Features	1
4. System example	1
5. Section name and functions	2
6. Camera mounting	2
7. Lens	2
8. Optical filter	3
9. Connector	4
10. Functions and operations	5
11. Remote control	7
12. Command list	14
13. CameraLink output timing chart	16
14. Trigger operation and timing chart	24
15. Input / Output signal	26
16. Spectral response	27
17. Specifications	28
18. Dimensions	29
19. About CD-ROM	30

The 5th edition in July, 2007.

Overview

KP-F500PCL/SCL are CameraLink output type black and white camera which utilized the 2/3 -inch progressive scan CCD image sensor with square pixel. KP-FR500PCL/SCL are RAW data output type.

It provide images of unparalleled quality at 16 frame per second non-interlaced output.

Since KP-F500PCL/FR500PCL are Power over CL type, PC can provide power to camera passed CameraLink cable.

Standard composition

Check when unpacking

Camera (with IR cut filter)	1
CD ROM (Documents and Control software)	1
Composition table / Software License	1

Optional accessories

(1) 12 pin plug	HR10A-10P-12S(01)
(2) Junction box	JU-F30/JC-100
(3) Dummy glass (AR coated)	ARC1214
(4) Tripod adaptor	TA-F500
(5) Mini-CameraLink cable	

(6) Camera cable

	Molded type	Shield type
2m	C-201KSM	C-201KSS
5m	C-501KSM	C-501KSS
10m	C-102KSM	C-102KSS

In the CE Marking region, use the shield type and install clamp filter (ZCAT 2035-0930A: TDK) at both ends (camera and video processor ends).

Features

•High resolution

The 2/3-inch 5,000,000 pixels square lattices CCD achieve a high resolution.

•Small and lightweight

The small SDR connector for digital output allows the camera size and mass to be drastically reduced to 44(W) x 44(H) x 41(D) mm / approx. 110g.

•Power over type CameraLink

KP-F500PCL/FR500PCL can be supplied by CameraLink cable.

System example

KP-F500PCL/SCL and KP-FR500PCL/SCL connect to frame grabber board using CameraLink cable.

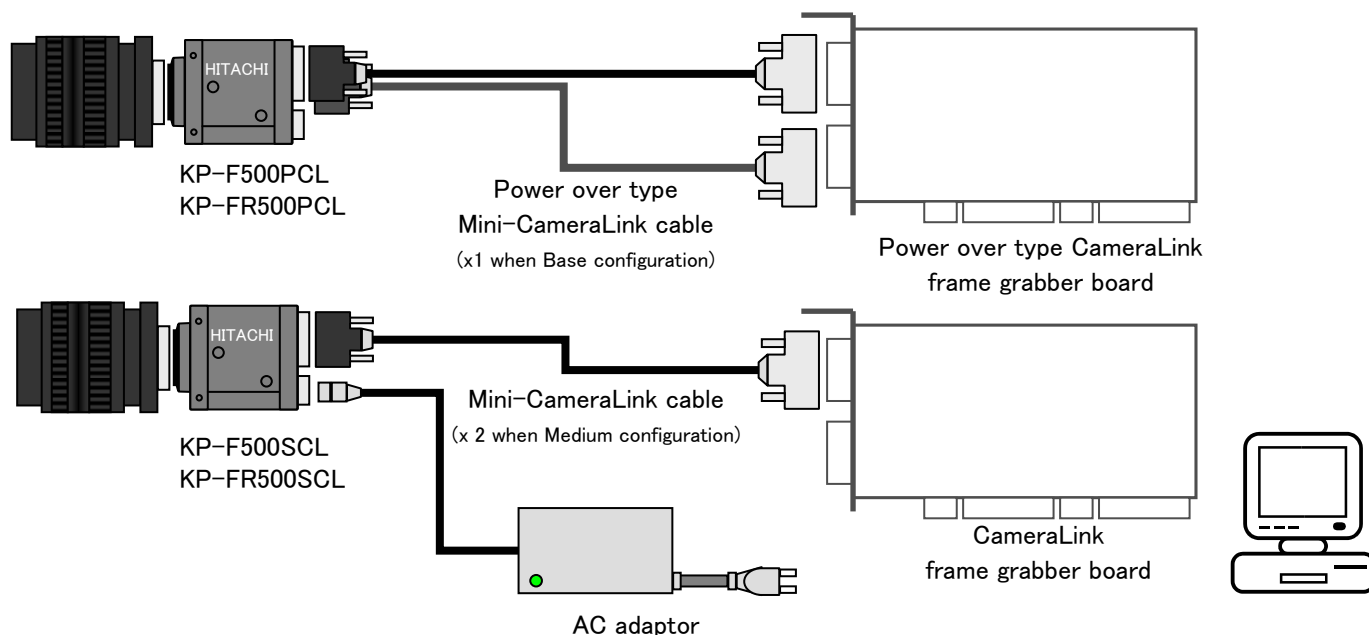

Section name and functions

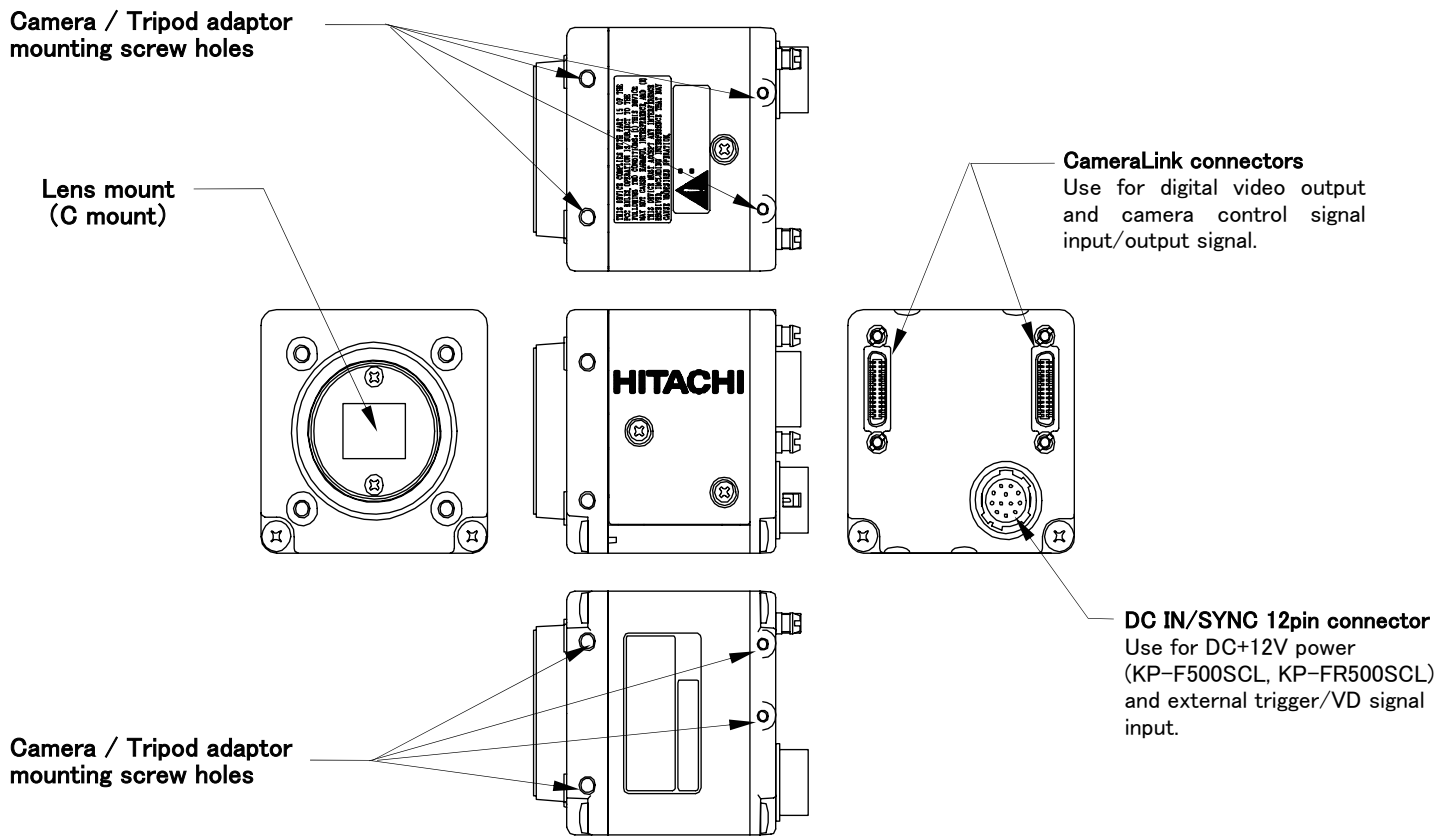

Camera mounting

Attached optional accessory the tripod adaptor "TA-F500", mount the camera to a tripod or mounting bracket.

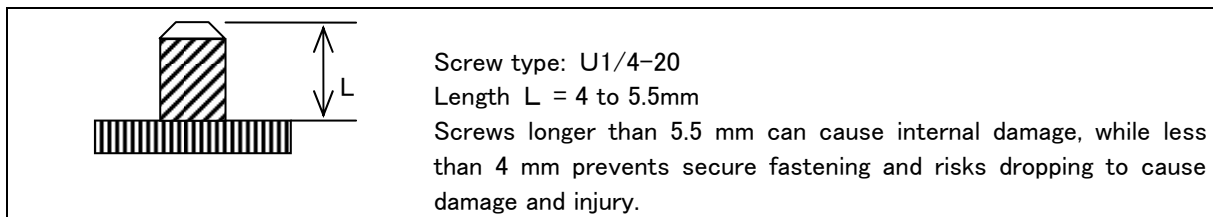

Lens

CAUTION
Observe the dimensions of the lens mounting selection as illustrated at the right.
If the dimensions are not observed, do not use such a lens, because the lens and the camera will be damaged.

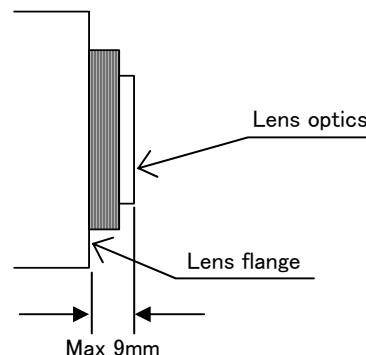

Optical filter

How to remove the IR cut filter.

- (1) Remove two screws ① and filter holder ② will come off.
- (2) Remove the IR cut filter ③ from filter frame ④.
- (3) Then, reinstall and secure filter holder ② with two screws ①.

Note: Prior to removing the optical filter, be sure to turn off the power.

Since garbage etc. invades into image reception surface camera,
please work under the clean air, such as a CLEAN ROOM.

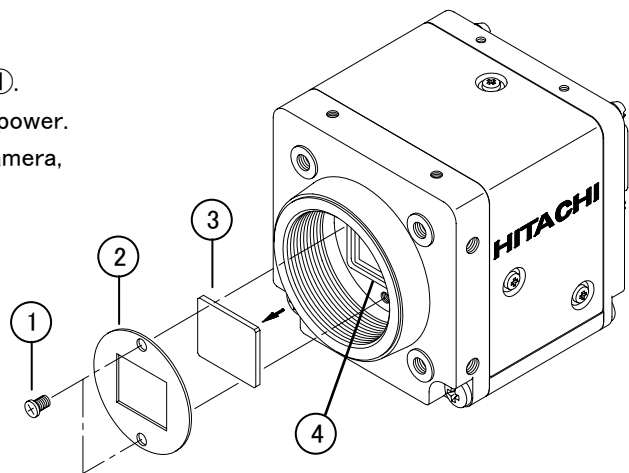

Connector

1. CameraLink connector

D.OUT1 (Connector 1)

Pin No.	Signal	Pin No.	Signal
1	+12V (KP-F500PCL/FR500PCL)	14	GND
	GND (KP-F500SCL/FR500SCL)		
2	TXOUT 0 (-)	15	TXOUT 0 (+)
3	TXOUT 1 (-)	16	TXOUT 1 (+)
4	TXOUT 2 (-)	17	TXOUT 2 (+)
5	TXCLKOUT (-)	18	TXCLKOUT (+)
6	TXOUT 3 (-)	19	TXOUT 3 (+)
7	RX (+) [SERTC (+)]	20	RX (-) [SERTC (-)]
8	TX (-) [SERTFG (-)]	21	TX (+) [SERTFG (+)]
9	TRIG-A/VD (-) [CC1 (-)]	22	TRIG-A/VD (+) [CC1 (+)]
10	NC [CC2 (+)]	23	NC [CC2 (-)]
11	NC [CC3 (-)]	24	NC [CC3 (+)]
12	NC [CC4 (+)]	25	NC [CC4 (-)]
13	GND	26	+12V (KP-F500PCL/FR500PCL)
			GND (KP-F500SCL/FR500SCL)

D.OUT2 (Connector 2: used for Medium configuration)

Pin No.	Signal	Pin No.	Signal
1	+12V (KP-F5000PCL/FR500PCL)	14	GND
	GND (KP-F500SCL/FR500SCL)		
2	TYOUT 0 (-)	15	TYOUT 0 (+)
3	TYOUT 1 (-)	16	TYOUT 1 (+)
4	TYOUT 2 (-)	17	TYOUT 2 (+)
5	TYCLKOUT (-)	18	TYCLKOUT (+)
6	TYOUT 3 (-)	19	TYOUT 3 (+)
7	NC	20	NC
8	NC	21	NC
9	NC	22	NC
10	NC	23	NC
11	NC	24	NC
12	NC	25	NC
13	GND	26	+12V (KP-F500PCL/FR500PCL)
			GND (KP-F500SCL/FR500SCL)

SDR connector (3M) or equivalent

- The digital out cable should be comprised of a twisted pair of wires having 100Ω characteristic impedance and an outer heath shield type conductor.
- Connect the shield (ground) of the digital out cable to the ground terminal of the video equipment, frame grabber, etc.
- TX: Transmit data from camera to PC
- RX: Transmit data from PC to camera

(Note) Please do not unplug and insert cable (digital out cable) with a power supplied to a camera.

2. DCIN connector

PIN NO.	Signal	PIN NO.	Signal
1	GND	7	Trigger/VD IN
2	---- (KP-F500PCL/FR500PCL)	8	GND
	+12V (KP-F500SCL/FR500SCL)		
3	GND	9	----
4	----	10	FLASH OUT / VD OUT
5	GND	11	----
6	----	12	GND

Connector (camera side) : SNH-10-12(RPCB) SAMWOO or equivalent

Plug (matching cable plug) : HR10A-10P-12S(01) HIROSE or equivalent

(Note) Please do not unplug and insert cable (camera cable) with a power supplied to a camera.

Install clamp filter (ZCAT 2035-0930A: TDK) at both ends (camera and video processor ends) in the CE marking legion.

Functions and operations

Various mode setup and adjustment of KP-F500PCL/SCL and KP-FR500PCL/FR500SCL are performed by the remote control via CameraLink.

Operation and adjustment way of function utilized in KP-F500PCL/SCL and KP-FR500PCL/SCL are described below. See "Remote control" and "Command list" (page 7 to 15) about communication method of each command.

1. Main functions

(1) TRIGGER : Setting about external trigger

•MODE : Select of mode

OFF (Factory setting) : Trigger mode set to OFF (normal mode).

FIXED SHUTTER : Set to Fixed shutter mode.

ONE TRIGGER : Set to ONE trigger mode.

VD CONTROL : Set to VD reset mode.

•POLARITY : Select of trigger polarity

POSITIVE (Factory setting) : Input polarity HIGH is made into trigger signal.

NEGATIVE : Input polarity LOW is made into trigger signal.

•SOURCE : Select of trigger source

CL-CC1 (Factory setting) : Input trigger signal from CameraLink signal CC1 (see page 4 "Connector").

12pin : Input trigger signal from 12 pin connector.

* See "Trigger operation and timing chart" (page 24 to 26).

(2) OUTPUT SIGNAL : Setting of output signal from 12 pin

OFF (Factory setting) : No output.

FLASH OUT : Output flash pulse (strobe out).

VD : Output camera VD.

(3) SHUTTER : Setting of electronic shutter

OFF (Factory setting) : Shutter operation set to OFF (normal shutter).

1/16, 1/60, 1/100, 1/250,

1/1000, 1/2000,

1/10000, 1/50000 second : Set to setting shutter speed (PRESET shutter).

VARIABLE : Set to shutter speed from 10 second to 1/100000 second (VARIABLE shutter).

-VARIABLE VALUE- : Setting speed of VARIABLE shutter.

10 to 1/100000 second : Electronic shutter can be set in the range of 10 to 1/100,000 second in 1536 steps.

Shutter speed setting value and exposure time can be derived as follows. (*ShutterSpeed*: μ second)

a) Setting value XY_{16} obtained from exposure time.

$$X = \text{int}(\log(\text{ShutterSpeed})) - 1$$

$$YY = \text{int}\left(\left(\frac{\text{ShutterSpeed}}{10^{X+1}} - 1\right) \times \frac{100_{16}}{9}\right)$$

b) Exposure time obtained from setting value XY_{16} .

$$\text{ShutterSpeed} = 10^{X+1} \times \left(1 + \frac{YY_{16}}{100_{16}} \times 9\right) [\mu \text{sec}]$$

Ex.1 Exposure time = setting value XY_{16} to obtain $1/125$ second (= 8000μ second).

$$X = \text{int}(\log(8000)) - 1 \\ = 2$$

$$YY = \text{int}\left(\left(\frac{8000}{10^{2+1}} - 1\right) \times \frac{100_{16}}{9}\right)$$

$$= \text{int}\left(7 \times \frac{100_{16}}{9}\right)$$

$$= C7_{16}$$

$$\therefore XY_{16} = 2C7_{16}$$

Ex.2 Setting value $25D_{16}$ that produces $1/234.22$ second exposure time.

$$\text{ShutterSpeed} = 10^{2+1} \times \left(1 + \frac{5D_{16}}{100_{16}} \times 9\right)$$

$$= 4269.53 \quad [\mu\text{sec}]$$

$$= \frac{1}{234.22} \quad [\text{sec}]$$

(4) CONFIGURATION : Setting of CameraLink configuration

BASE (Factory setting) : Connection is switched to Base configuration.

MEDIUM : Connection is switched to Medium configuration.

(5) DATA BIT : Setting of output bit depth

8bit (Factory setting) : Image is outputted by 8 bit.

10bit : Image is outputted by 10 bit.

12bit : Image is outputted by 12 bit.

(6) VD/FVAL : Setting of vertical sync signal

VD : Output VD.

FVAL (Factory setting) : Output FVAL.

(7) HD/LVAL : Setting of horizontal sync signal

HD : Output HD.

LVAL (Factory setting) : Output LVAL.

LVAL2 : Output LVAL2 and horizontal pixel is set to 1224 (multiple of 8) clocks.

(8) GAIN : Setting of electrical sensitivity

0 (Factory setting) to 18dB : Set from 0 to 18dB in 504 steps (for KP-F500PCL/SCL).

0 (Factory setting) to 12dB : Set from 0 to 12dB in 336 steps (for KP-FR500PCL/SCL).

(9) BLACK LEVEL : Adjust offset level

0 (Factory setting) to 63 : Set in 64 steps.

(10) VERTICAL 2 PIXEL ADDITION : Setting of vertical two pixel addition

*This function is only for KP-F500PCL/SCL.

OFF (Factory setting) : Not perform vertical two pixel addition.

ON : Perform vertical two pixels addition and frame rate is increased about 2 times.

(11) PARTIAL SCAN : Setting about partial scan

-MODE- : Select of mode

OFF (Factory setting) : Not perform partial scan.

ON : Perform partial scan.

-START- : Start position of partial scan

1 (Factory setting) to 2058: Scan is started from the line set up in 1 to 2058.

-WIDTH- : Width of partial scan

1 to 2058 (Factory setting): Scan is performed number of line set up in 1 to 2058 is scanned.

* When using partial scan, please make sum total of START and WIDTH into 2059 or less.

* When using partial scan, please use FVAL.

Remote control

1. Comms* specifications

- Control system : Start-stop synchronization system
- Transmission rate : 9600 bps
- Data length : 8 bit
- Star bit : 1 bit
- Stop bit : 1 bit
- Parity : None
- Bit transfer : LSB first

*Comms: Communications

2. Comms control

The remote control software controls all communications. Data send/receive (BSC handshake) is by transferring TEXT data to the camera controller chip.

3. Comms procedure

The following pages indicate the camera controller chip and remote control software data protocol. In the description, the camera is designated as slave and the software as master.

- Receive protect timer (time out error)

The receive protect timer for master and slave processes is 1 second. For example, if 1 block of TEXT data is being received, if the data interval exceeds 1 second, error is produced and the data are lost. An acknowledgment of data receipt is not produced.

(1) Transmission from master (normal process)

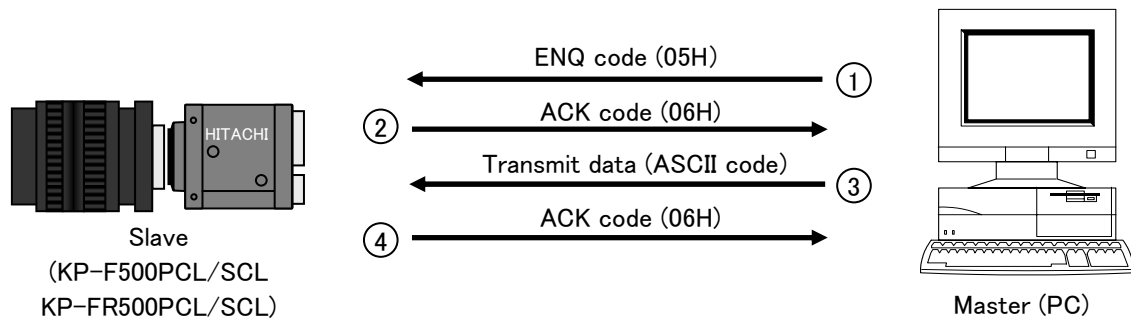

- ① Session starts when ENQ is sent from master to slave.
- ② Slave acknowledges by returning ACK to master.
- ③ Master sends data to slave.
- ④ Slave acknowledges receipt of data by again returning ACK to master and end the handshake.

(2) Master reads data (normal process)

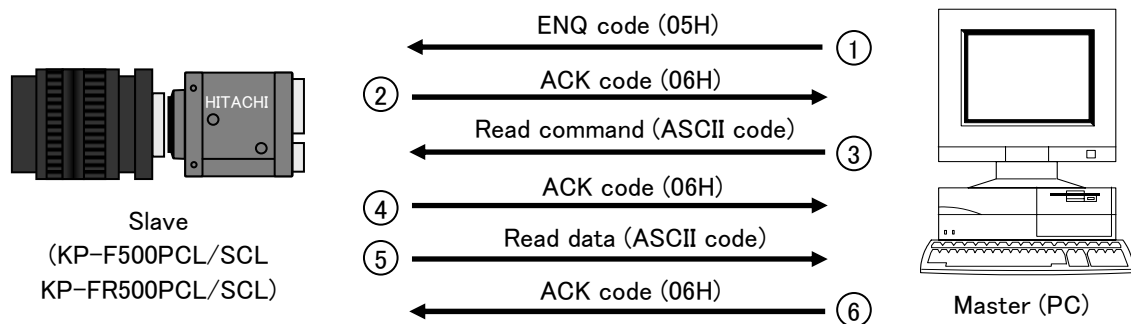

- ① Session starts when ENQ is sent from master to slave.
- ② Slave acknowledges by returning ACK to master.
- ③ Master sends read command to slave.
- ④ Slave receives read command, then acknowledges by returning ACK code to master.
- ⑤ Slave sends read data to master.
- ⑥ Master receives read data, then acknowledges by returning ACK code to slave.

(3) Data transmitted by master (control abort process)

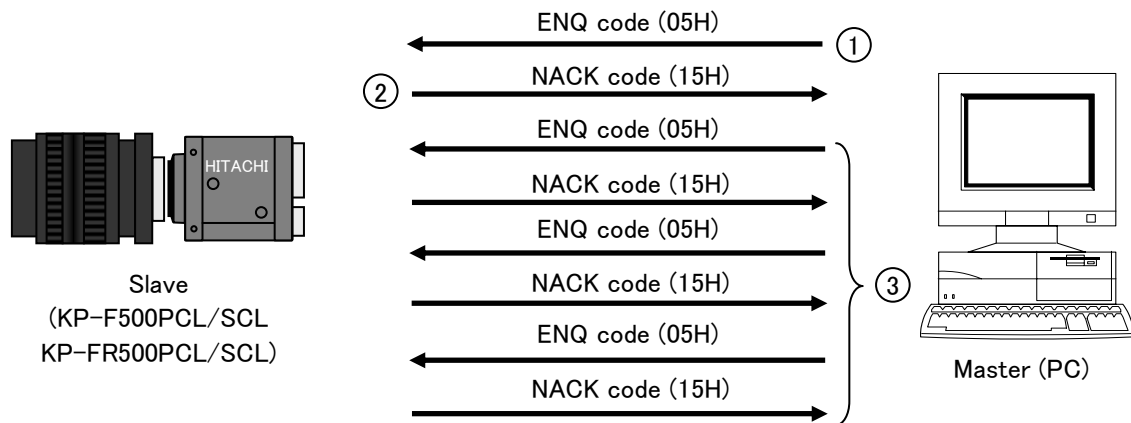

- ① Master sends ENQ code to slave.
- ② Since ACK code cannot be sent, slave sent NACK code to master.
- ③ Sequence is repeated 3 times in attempts to retransmit.
After receiving the 3rd successive NACK code, communications control is aborted

(4) Data transmitted by master (data error process)

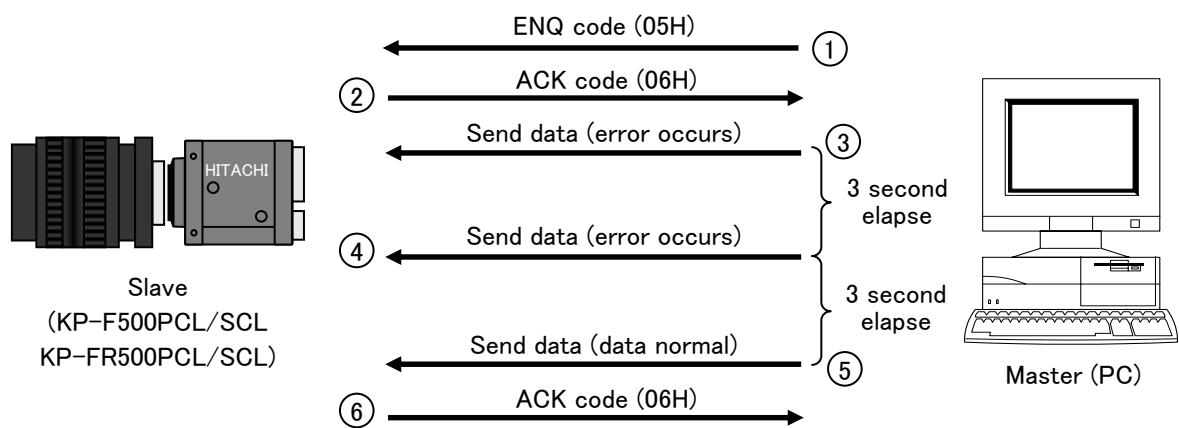

- ① Session starts when ENQ is sent from master to slave.
- ② Slave acknowledges by returning ACK to master.
- ③ Master sends data, but slave detect error (framing, over-run error).
- ④ Slave detects error and does not accept data.
- ⑤ Sequence 3 and 4 repeats, then master transfers normal data.
- ⑥ Slave detects normal data and returns ACK code to master to end the session.

(5) Data frame error (Master transmission)

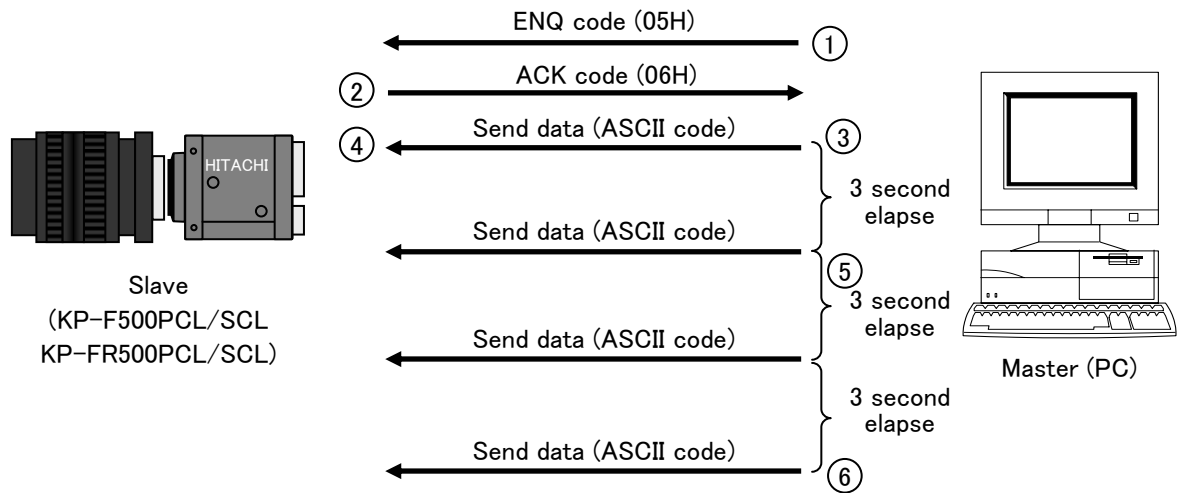

- ① Session starts when ENQ is sent from master to slave.
- ② Slave acknowledges by returning ACK to master.
- ③ Master sends data.
- ④ For some reason, slave does not receive data.
- ⑤ Master does not receive acknowledgment to the send code and repeats the sequence every 3 seconds for 3 times.
- ⑥ If unsuccessful after 3 attempts, master aborts the sequence and ends communication.

(6) Transmission frame error (Master receive)

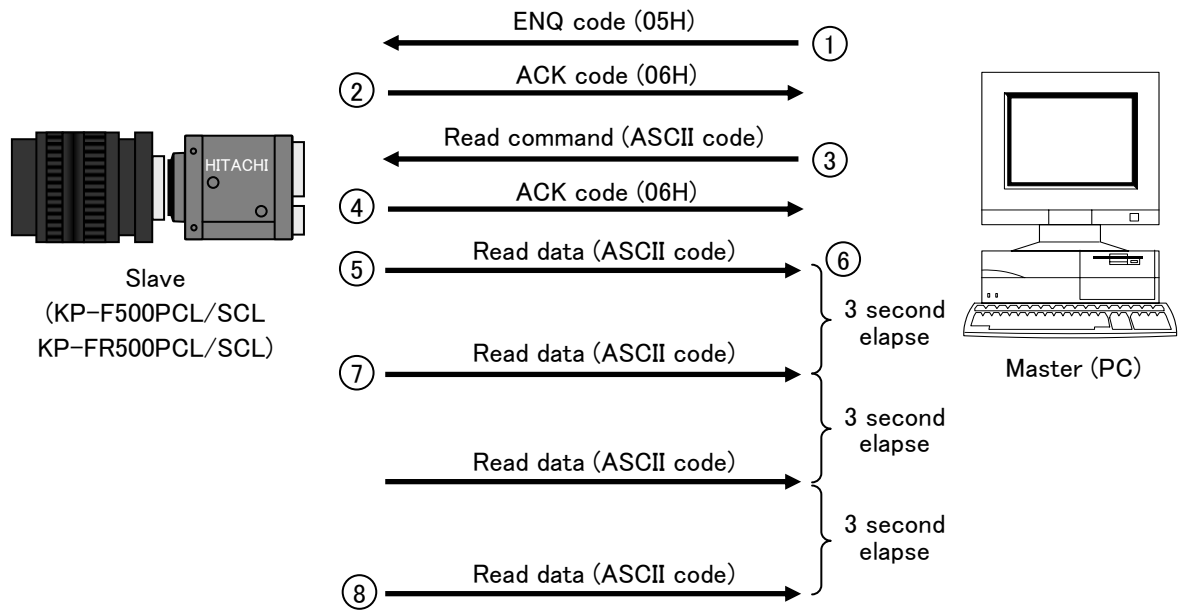

- ① Session starts when ENQ is sent from master to slave.
- ② Slave acknowledges by returning ACK to master.
- ③ Master sends read command.
- ④ Slave returns ACK code to acknowledge read command.
- ⑤ Slave sends read data to master.
- ⑥ For some reason, master fails to receive read data.
- ⑦ Slave fails to receive acknowledgment of read data and attempts to resend every 3 seconds for 3 times.
- ⑧ After the third failure, slave aborts the sequence and ends communication.

4. Comms command data format

(1) Send data and read command (master to slave)

(a) Command data are converted into ASCII code and transmitted.

(b) Comms byte quantity is 18.

(c) Comms data format (transmission sequence).



- STX (start code) : Code indicating start of text.
1 byte (02H)
- Text data : Transmit / receive data.
14 byte (ASCII code)
- ETX (end code) : Code indicating end of text.
1 byte (03H)
- SUM : XOR result (FFH), of adding STX, Text data, and ETX.
2 byte (ASCII code)

(d) Text data format details (transmission sequence).

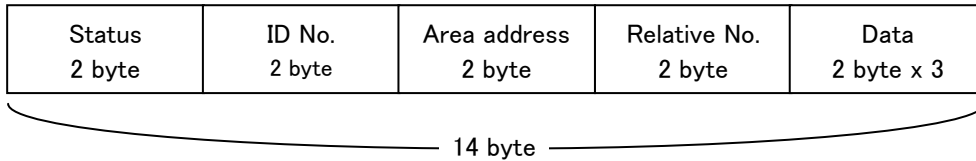

- Status : Transmission data status.
2 byte (ASCII code)
Used for EEPROM write (0: write absent, 1: write present).
- ID No. : Camera peculiar ID.
KP-F500PCL/SCL and KP-FR500PCL/SCL have (FFH).
2 byte (ASCII code)
- Area address : Classification of Send data (01H) and Read command (81H).
2 byte (ASCII code)
- Relative No. : Sets number (0 to 255) for each adjustment item.
2 byte (ASCII code)
- Data (note) : Sets data to be transmitted.
2 byte x 3 (ASCII code)

(2) Read (receive) data (slave to master)

(a) Command data are converted into ASCII code and transmitted.

(b) Comms byte quantity is 10.

(c) Comms data format (transmission sequence)

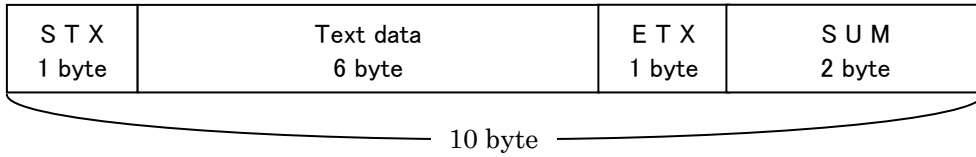

- STX (start code) : Code indicating start of text.
1 byte (02H)
- Text data : Transmit / receive data.
6 byte (ASCII code)
- ETX (end code) : Code indicating end of text.
1 byte (03H)
- SUM : XOR result (FFH), of adding STX, Text data, and ETX.
2 byte (ASCII code)

(d) Text data details (transmission sequence)

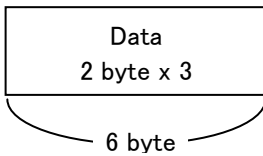

- Data (note) : Sets Read data to be transmitted.
2 byte x 3 (ASCII code)

Note: Data transfer sequence

Area address	Data type	Data bytes	1st byte	2nd byte	3rd byte
0x01 (Send data), 0x81 (Read command)	Common data	1	Data	0x00	0x00
		2	Upper	Lower	0x00
		3	Upper	Mid	Lower

5. Calculation method of checksum

Example

STX	1	2	3	4	5	6	7	ETX	SUM
	STATUS	ID NO	AREA ADDRESS	RELATIVE NO	DATA				
02	01	FF	01	04	00	00	00	03	28

1. STAUTUS to DATA are transformed into hexadecimal number on the basis of the ASCII code.

'0'→(30)₁₆ '1'→(31)₁₆ '4'→(34)₁₆ 'F'→(46)₁₆ STX: (02)₁₆ ETX: (03)₁₆

2. STX to ETX are added all.

$$(02)_{16} + (30)_{16} + (31)_{16} + (46)_{16} + (46)_{16} + (30)_{16} + (31)_{16} + (30)_{16} + (34)_{16} + (30)_{16} + (30)_{16} + (30)_{16} + (30)_{16} + (30)_{16} + (03)_{16} = (2D7)_{16}$$

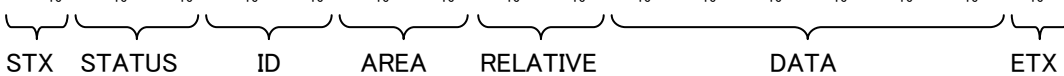

3. The XOR (Exclusive OR) between the value obtained in 2 clause and (FF)₁₆ are taken, then two column under the answer become SUM

(2D7)₁₆ XOR (FF)₁₆ = (228)₁₆

Command list

1. Send data (Setting command. Note: 1 to 7 and SUM need to be transformed into ASCII code)

Item		STX	1	2	3	4	5	6	7	ETX	SUM	
			STATUS	ID NO.	AREA ADDRESS	RELATIVE NO.	DATA					
TRIGGER	MODE	OFF	02	01	FF	01	04	00	00	00	03	28
		FIXED	02	01	FF	01	04	01	00	00	03	27
		1TRIG	02	01	FF	01	04	02	00	00	03	26
		VD CONT	02	01	FF	01	04	04	00	00	03	24
	POLARITY	POSITIVE	02	01	FF	01	0F	00	00	00	03	16
		NEGATIVE	02	01	FF	01	0F	01	00	00	03	15
	SOURCE	CL-CC1	02	01	FF	01	05	00	00	00	03	26
12pin		02	01	FF	01	05	01	00	00	03	25	
OUTPUT SIGNAL		OFF	02	01	FF	01	06	00	00	00	03	26
		FLASH OUT	02	01	FF	01	06	01	00	00	03	25
		VD	02	01	FF	01	06	02	00	00	03	24
SHUTTER SPEED (*1)	PRESET	OFF	02	01	FF	01	08	00	00	00	03	24
		1/16	02	01	FF	01	08	01	00	00	03	23
		1/60	02	01	FF	01	08	02	00	00	03	22
		1/100	02	01	FF	01	08	03	00	00	03	21
		1/250	02	01	FF	01	08	04	00	00	03	20
		1/1000	02	01	FF	01	08	05	00	00	03	1F
		1/2000	02	01	FF	01	08	06	00	00	03	1E
		1/10000	02	01	FF	01	08	07	00	00	03	1D
		1/50000	02	01	FF	01	08	08	00	00	03	1C
	VARIABLE (*2)	02	01	FF	01	08	FF	00	00	03	F8	
VARIABLE VALUE (2Byte) (*2)	MIN (1/100000(s))	02	01	FF	01	11	00 (*3)	00 (*3)	00	03	2A	
	MAX (10(s))	02	01	FF	01	11	06 (*3)	00 (*3)	00	03	1E	
CONFIGURATION		BASE	02	01	FF	01	12	00	00	00	03	29
		MEDIUM	02	01	FF	01	12	01	00	00	03	28
DATA BIT	8bit	02	01	FF	01	14	00	00	00	03	27	
	10bit	02	01	FF	01	14	01	00	00	03	26	
	12bit	02	01	FF	01	14	02	00	00	03	25	
VD/FVAL	VD	02	01	FF	01	15	00	00	00	03	26	
	FVAL	02	01	FF	01	15	01	00	00	03	25	
HD/LVAL	HD	02	01	FF	01	16	00	00	00	03	25	
	LVAL	02	01	FF	01	16	01	00	00	03	24	
	LVAL2	02	01	FF	01	16	02	00	00	03	23	
GAIN (2Byte)	MIN (0)	02	01	FF	01	0C	00 (*4)	00 (*4)	00	03	19	
	MAX (503/336) (*4)	02	01	FF	01	0C	01 (*4)	F7/50(*4)	00	03	FB/13	
BLACK LEVEL	MIN (0)	02	01	FF	01	17	00 (*5)	00	00	03	24	
	MAX (63)	02	01	FF	01	17	3F (*5)	00	00	03	0B	
VERTICAL 2 PIXEL ADDITION (*6)		OFF	02	01	FF	01	13	00	00	00	03	28
		ON	02	01	FF	01	13	01	00	00	03	27
PARTIAL SCAN	MODE	OFF	02	01	FF	01	1E	00	00	00	03	16
		ON (*6)	02	01	FF	01	1E	01	00	00	03	15
	START (2BYTE) (*7)	MIN (1)	02	01	FF	01	1F	00	01	00	03	14
		MAX (2058)	02	01	FF	01	1F	08 (*8)	0A (*8)	00	03	FC
	WIDTH (2BYTE) (*7)	MIN (1)	02	01	FF	01	20	00	01	00	03	29
MAX (2058)		02	01	FF	01	20	08 (*8)	0A (*8)	00	03	11	

(*1) SHUTTER SPEED settings are effective only in the condition TRIGGER MODE is OFF or FIXED SHUTTER.

(*2) VARIABLE VALUE can be set only when VARIABLE is selected.

(*3) VARIABLE VALUE: selectable in the range from 0000 to 0600₁₆ (See page 5 to 6 about setting shutter speed).

(*4) GAIN: selectable in the range from 0000₁₆ to 01F7₁₆: KP-F500PCL/SCL.

from 0000₁₆ to 0150₁₆: KP-FR500PCL/SCL.

(*5) BLACK LEVEL: selectable in the range from 00₁₆ to 3F₁₆.

(*6) VERTICAL 2 PIXEL ADDITION is only for KP-F500PCL/SCL.

(*7) PARTIAL SCAN START/WIDTH can be set only when PARTIAL SCAN MODE is ON.

(*8) PARTIAL SCAN START/WIDTH: selectable in the range from 0001₁₆ to 080A₁₆ and the sum total of START and WIDTH is 080A₁₆ or less.

2. Read command (Note: 1 to 7 and SUM need to be transformed into ASCII code)

Item		STX	1	2	3	4	5	6	7	ETX	SUM
			STATUS	ID NO.	AREA ADDRESS	RELATIVE NO.	DATA				
TRIGGER	MODE	02	00	FF	81	04	00	00	00	03	21
	POLARITY	02	00	FF	81	0F	00	00	00	03	10
SHUTTER SPEED	PRESET	02	00	FF	81	08	00	00	00	03	1D
	VARIABLE VALUE	02	00	FF	81	11	00	00	00	03	23
CONFIGURATION		02	00	FF	81	12	00	00	00	03	22
DATA BIT		02	00	FF	81	14	00	00	00	03	20
VD / FVAL		02	00	FF	81	15	00	00	00	03	1F
HD / LVAL		02	00	FF	81	16	00	00	00	03	1E
GAIN		02	00	FF	81	0C	00	00	00	03	12
BLACK LEVEL		02	00	FF	81	17	00	00	00	03	1D
VERTICAL 2 PIXEL ADDITION (*1)		02	00	FF	81	13	00	00	00	03	21
PARTIAL SCAN	MODE	02	00	FF	81	1E	00	00	00	03	0F
	START	02	00	FF	81	1F	00	00	00	03	0E
	WIDTH	02	00	FF	81	20	00	00	00	03	23

(*1) VERTICAL 2 PIXEL ADDITION is only for KP-F500PCL/SCL.

Read data from Slave is based on 4. (2).

CameraLink output timing chart

1. Horizontal timing

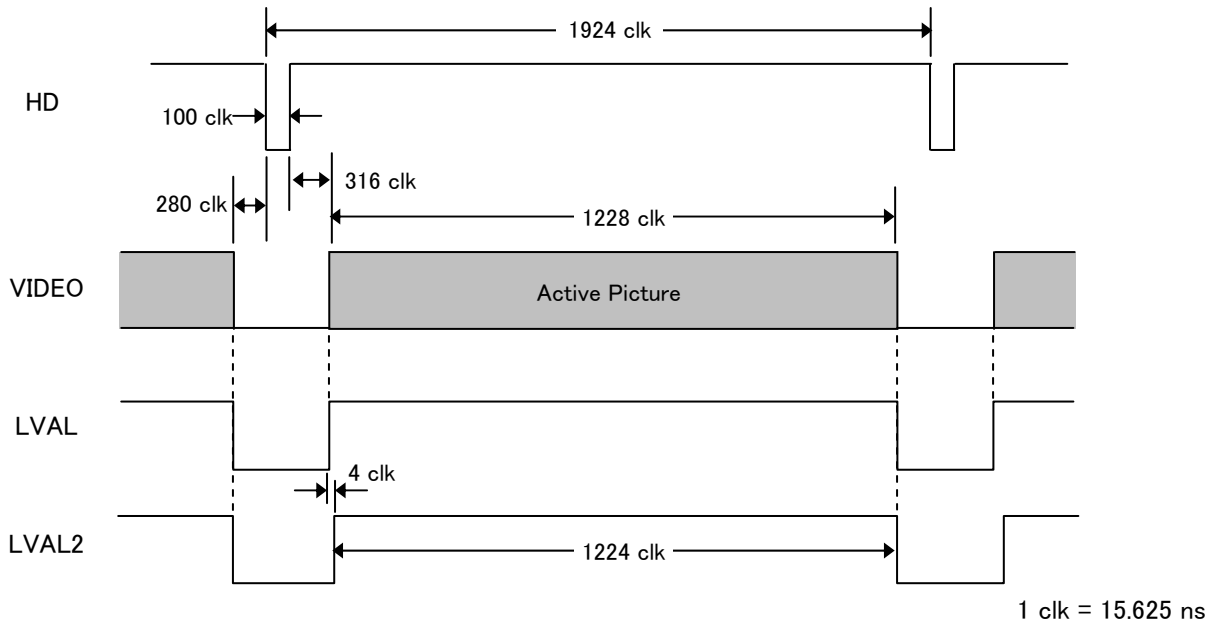

2. Vertical timing

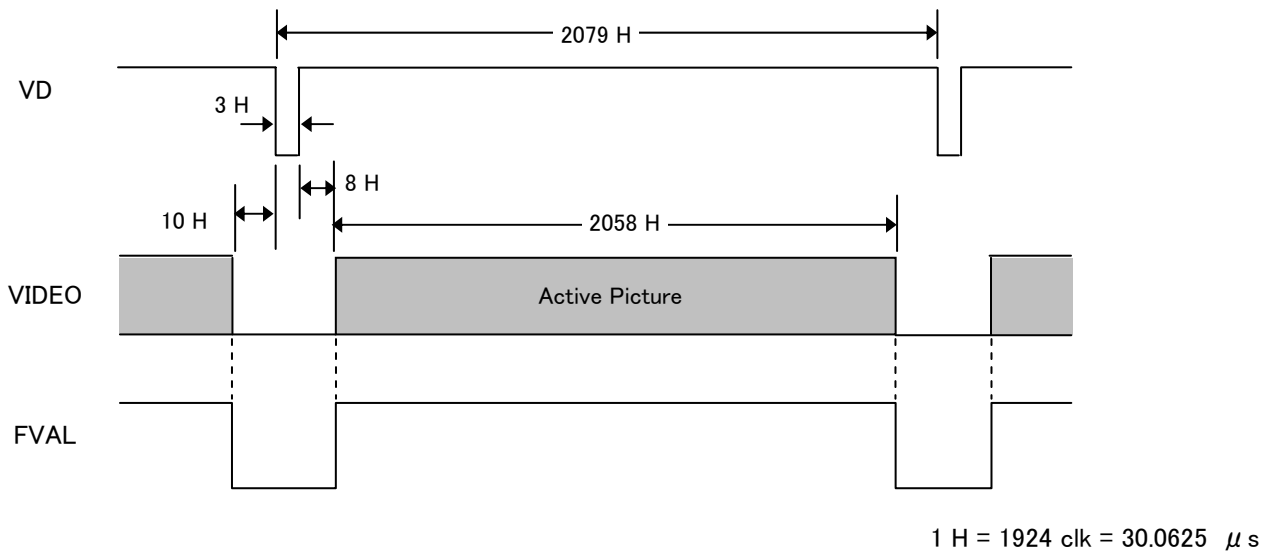

* Vertical timing for vertical 2 pixel addition mode

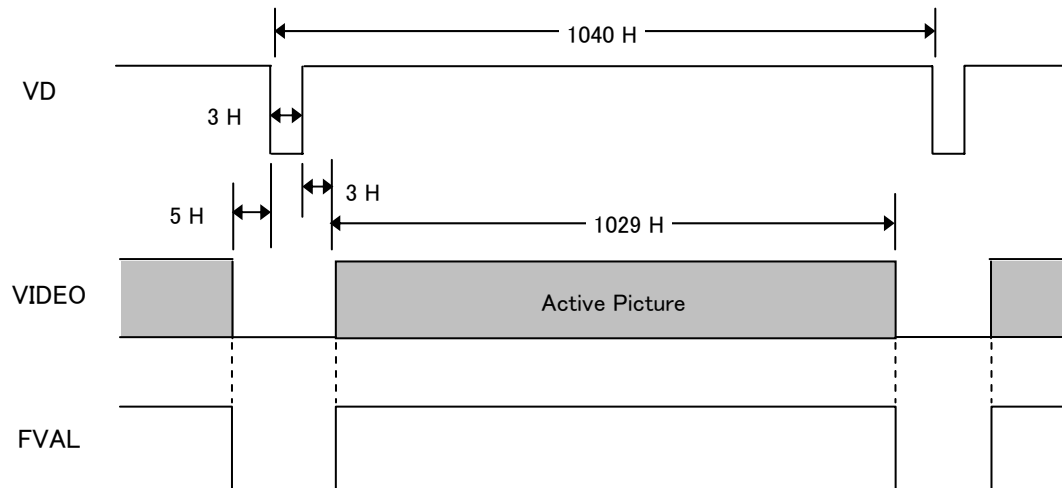

(c) 12bit
D.OUT1

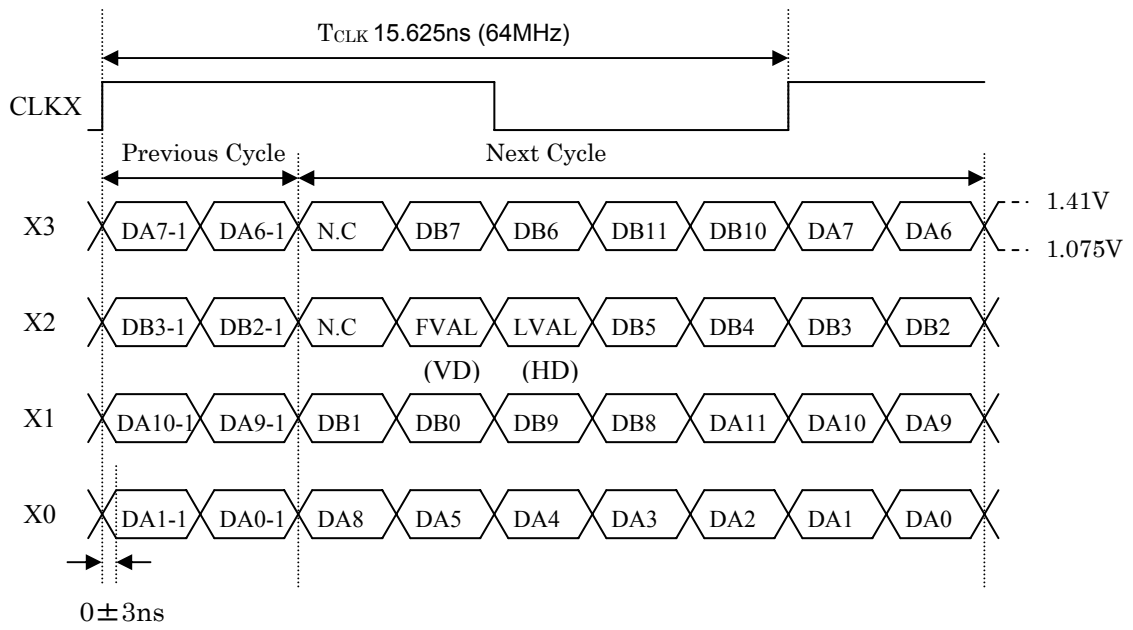

When using at Base configuration, please be sure to connect CameraLink cable to D.OUT1. If the cable is connected to D.OUT2, machine may break down.

(2) Medium configuration

(a) 8bit

D.OUT1

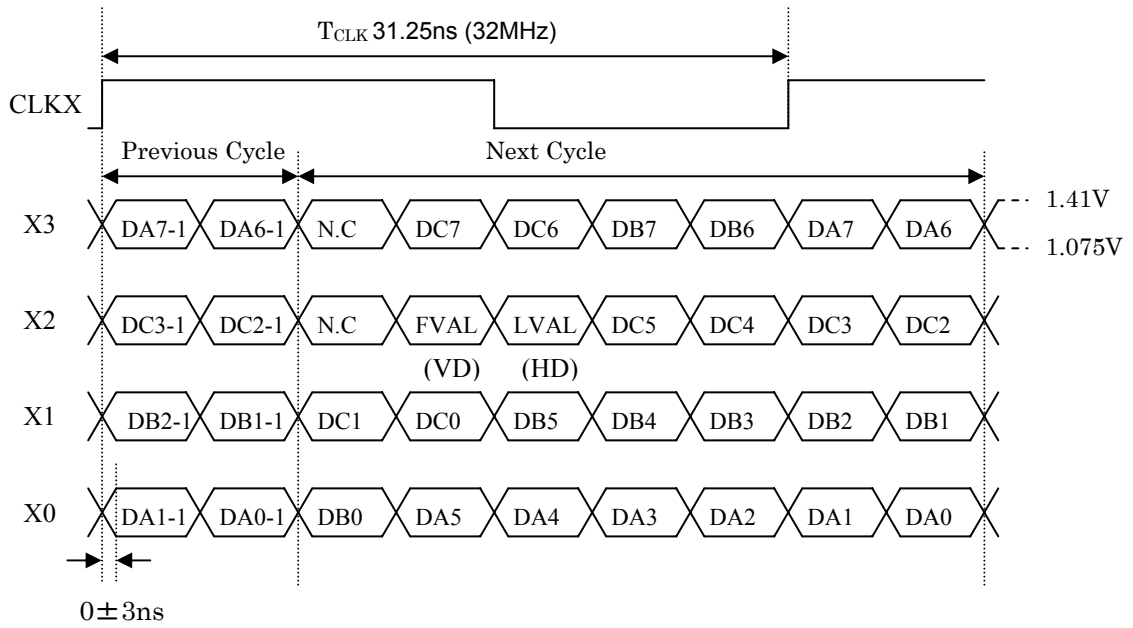

D.OUT2

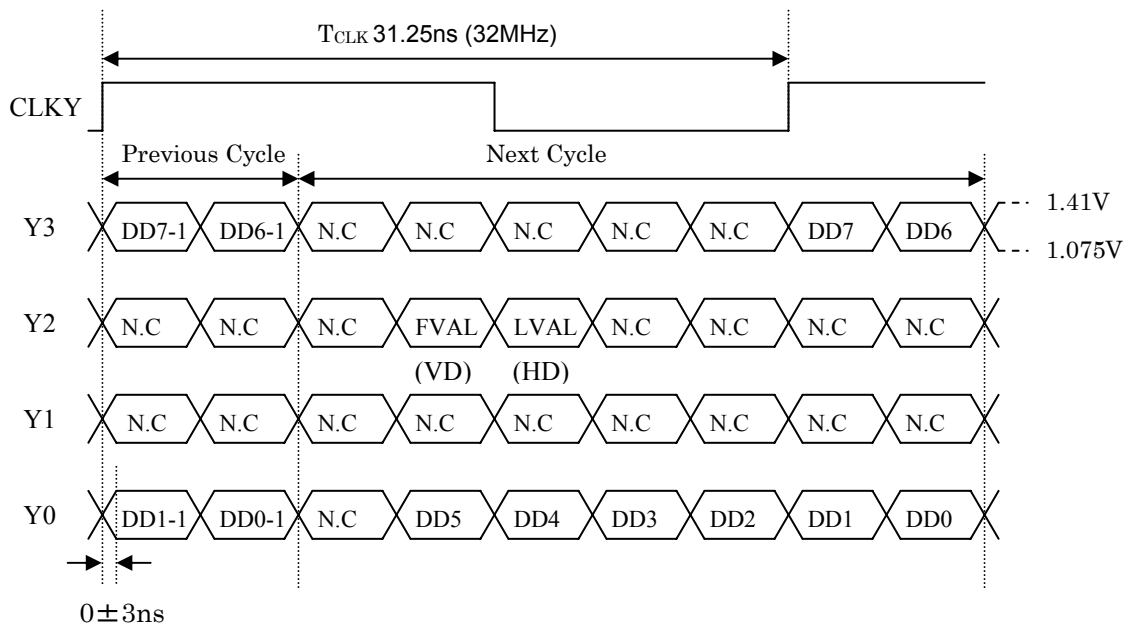

(b) 10bit
D.OUT1

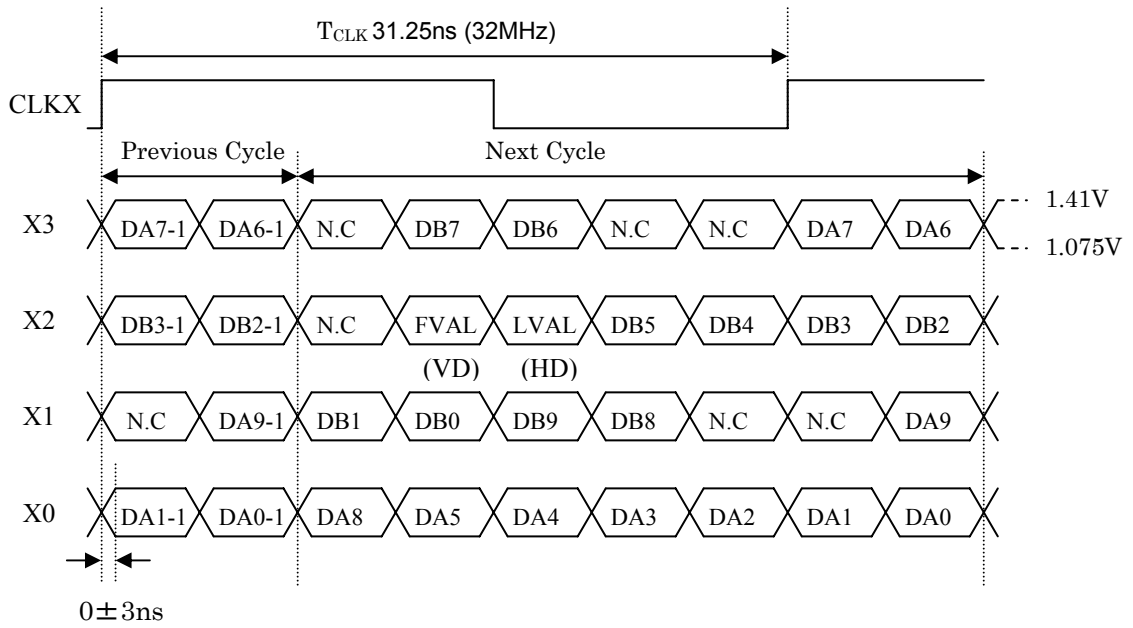

D.OUT2

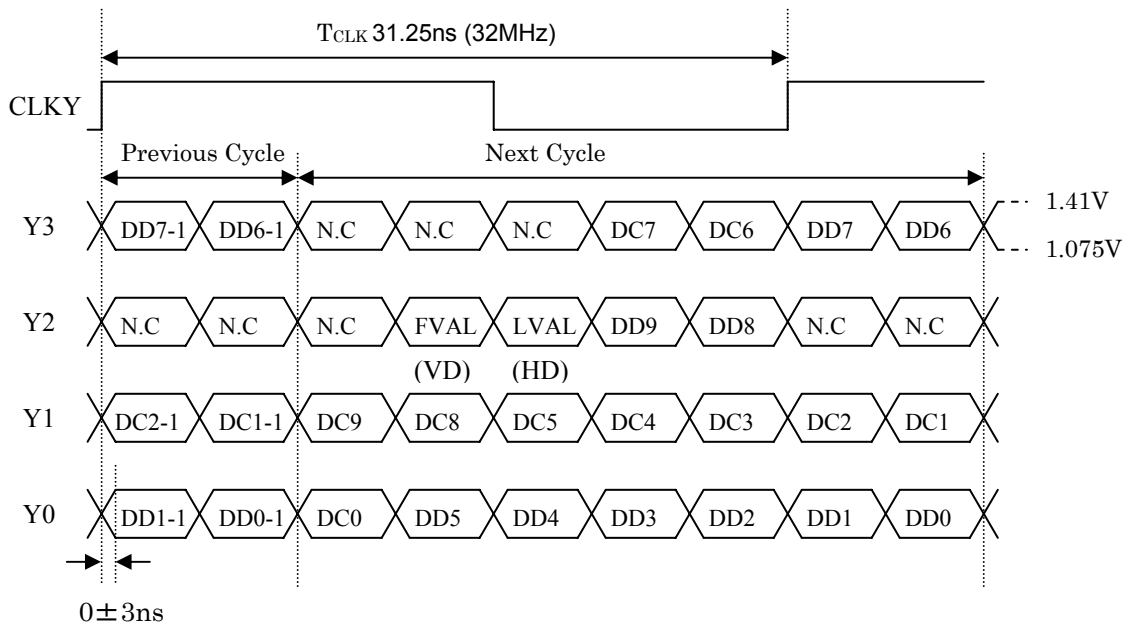

(c) 12bit
D.OUT1

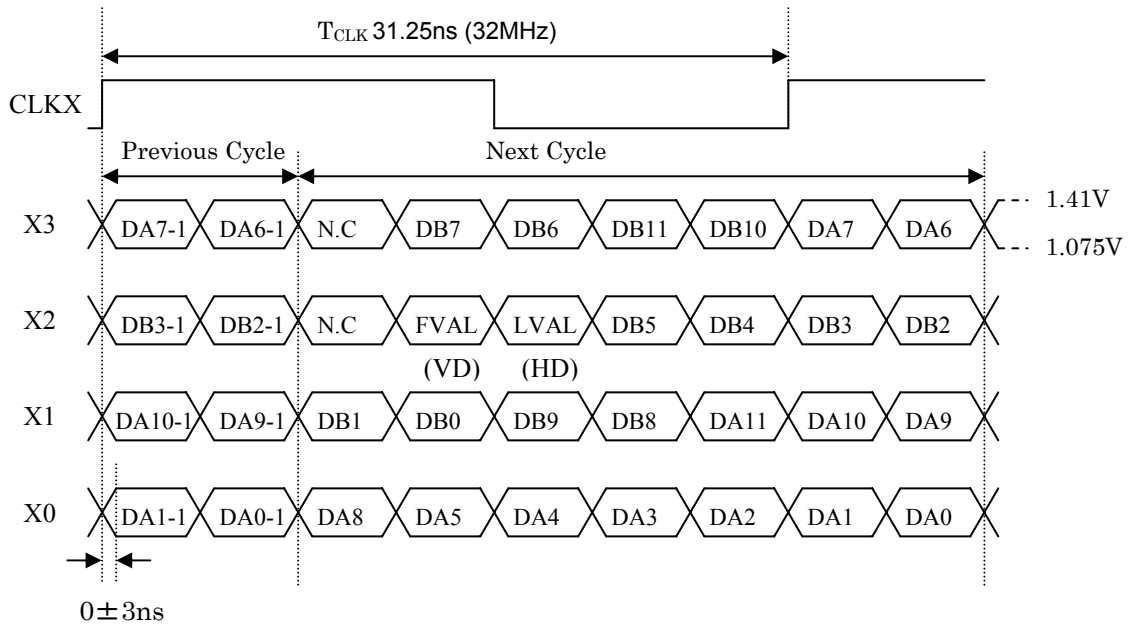

D.OUT2

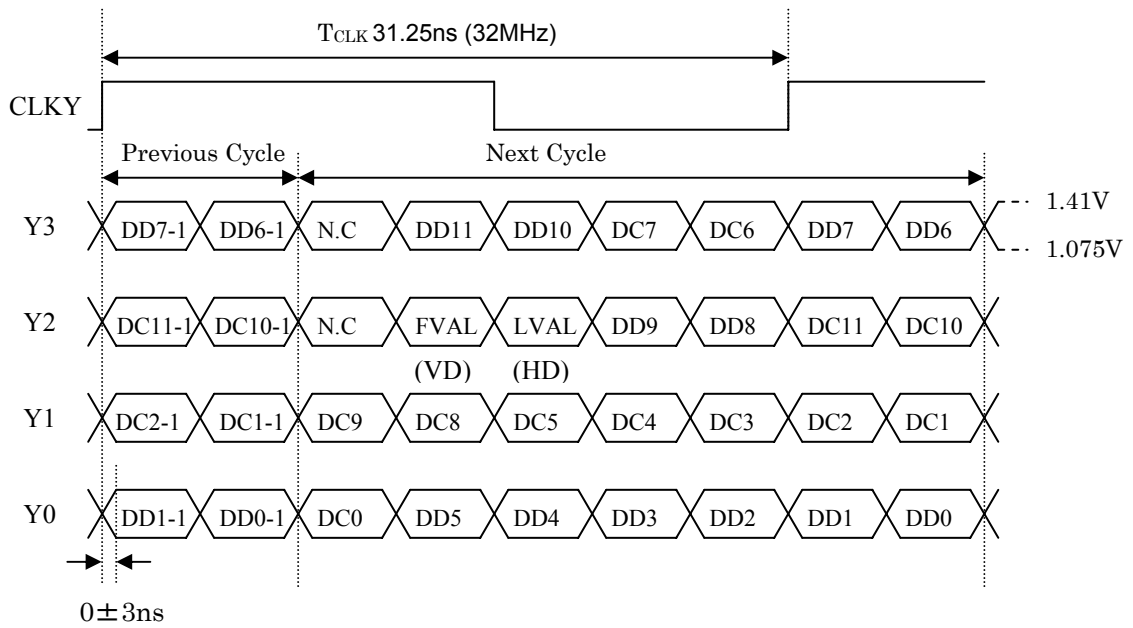

4. Output sequence

(1) KP-F500PCL/SCL

It shows KP-F500PCL/SCL output sequence of image data.

$$X = H/2$$

$$H = 2456$$

$$V = 2058$$

(a) Base configuration

DA_{xy} : Data of screen left half. This means that left to the x -th pixel on y -th line.

DB_{xy} : Data of screen right half. This means that right to the x -th pixel on y -th line.

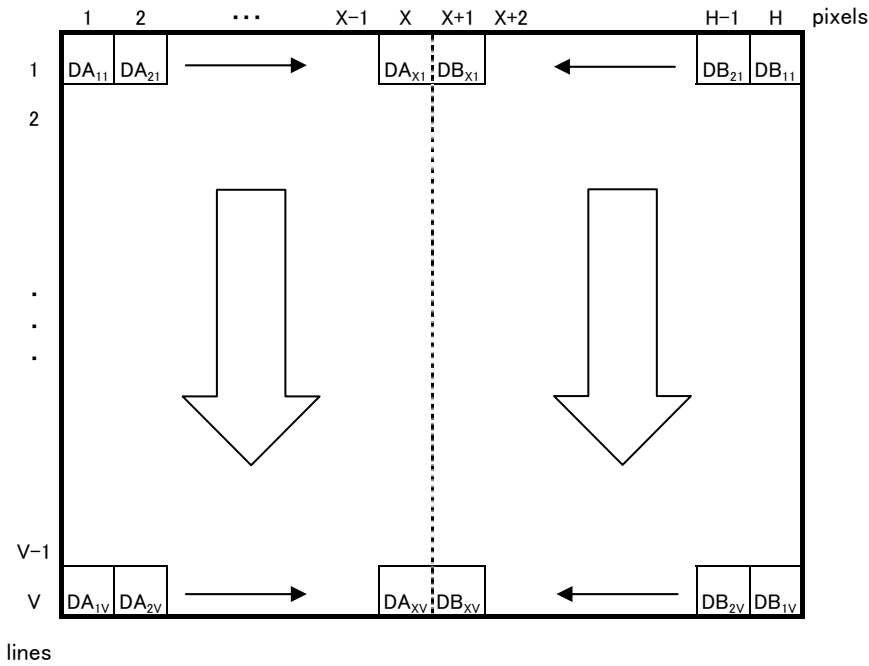

(b) Medium configuration

DA_{xy} DB_{xy} : Data of screen left half. These mean that left to the x -th pixel on y -th line.

DC_{xy} DD_{xy} : Data of screen right half. These mean that right to the x -th pixel on y -th line.

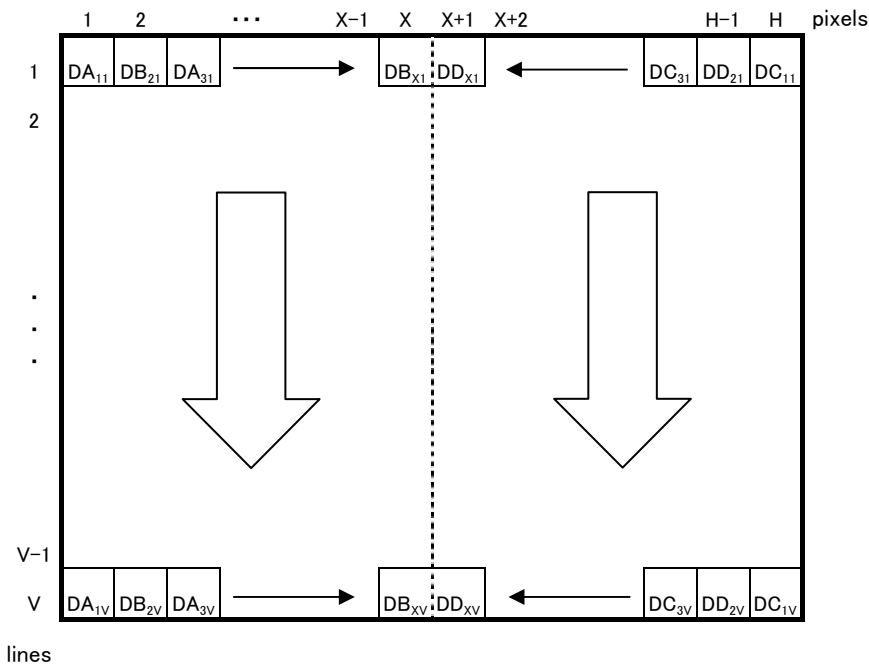

(2) KP-FR500PCL/SCL

It shows KP-FR500PCL/SCL output sequence of RAW data.

$$X = H/2$$

$$H = 2456$$

$$V = 2058$$

(a) Base configuration

R(DA) G(DA) B(DA) : Data of screen left half. These mean R component, G component and B component.

R(DB) G(DB) B(DB) : Data of screen right half. These mean R component, G component and B component.

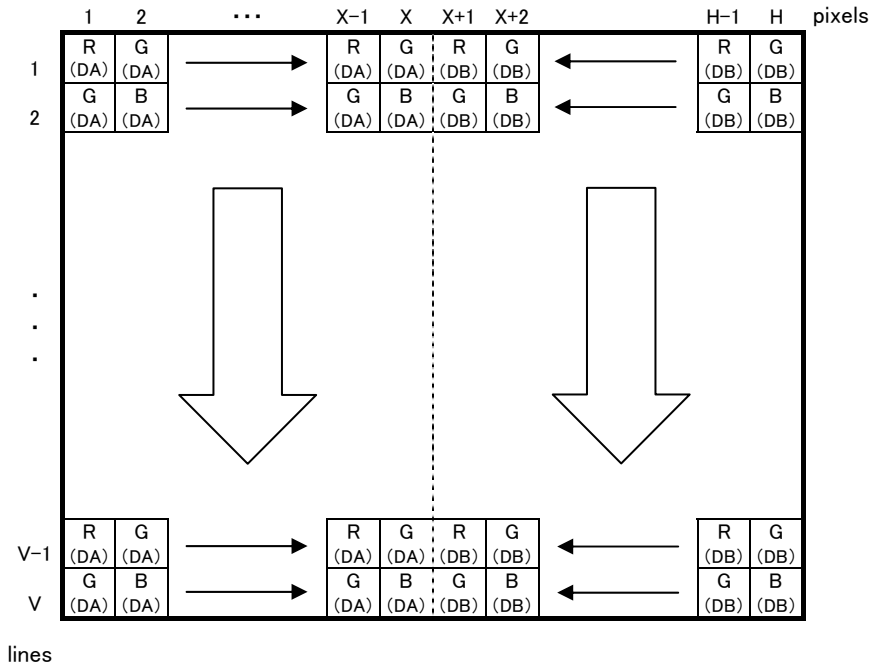

(b) Medium configuration

R(DA) G(DA) G(DB) B(DB) : Data of screen left half. These mean R component, G component and B component.

R(DD) G(DC) G(DD) B(DC) : Data of screen right half. These mean R component, G component and B component.

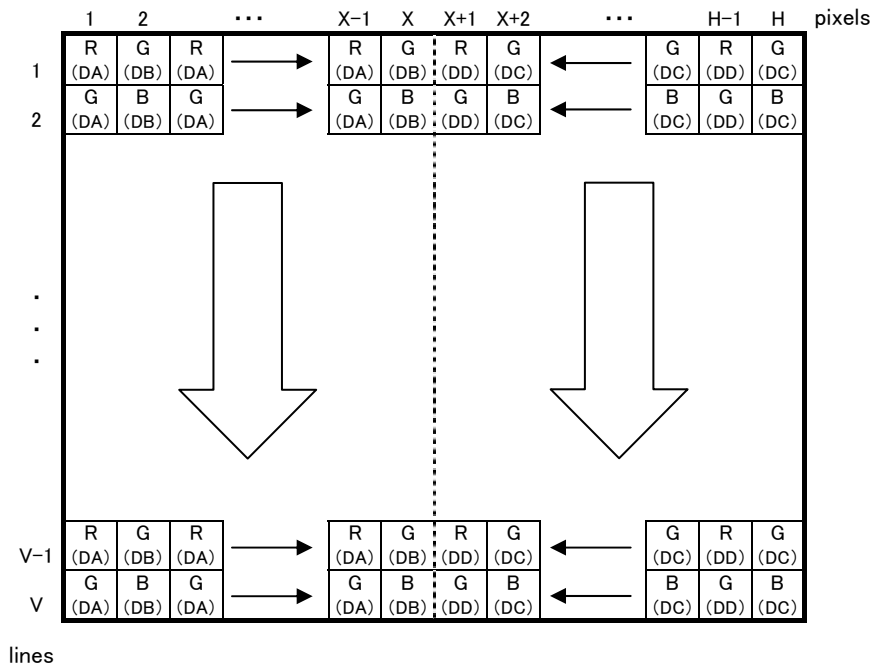

Trigger operation and timing chart

1. Normal mode

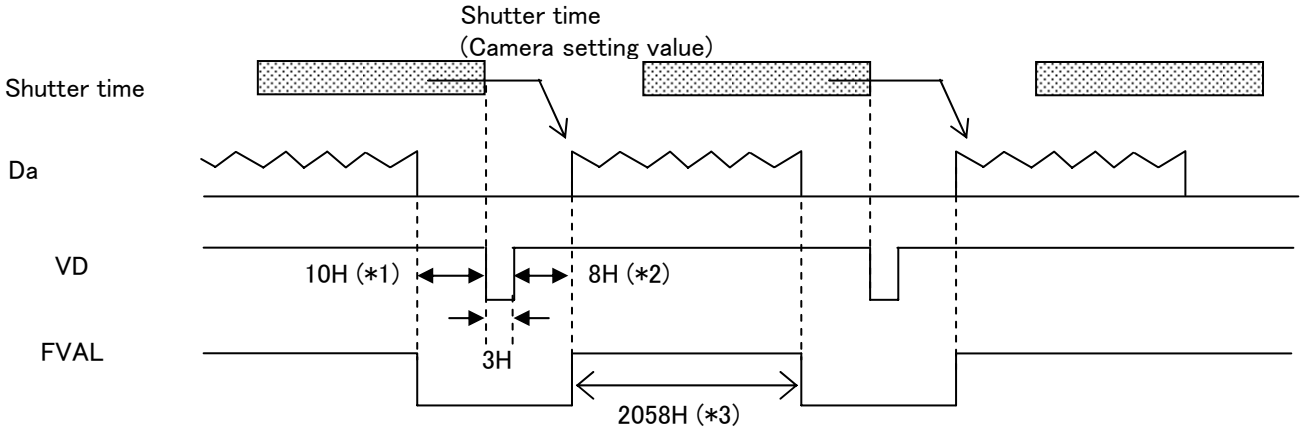

*1: When partial scan, variable by setting.

*2: When partial scan, variable by start position of picture grabbing.

*3: When partial scan, variable by set width of picture grabbing.

5H when vertical two pixel addition.

4H when vertical two pixel addition.

1029H when vertical two pixel addition.

Graph following shows frame rate in each of picture grabbing in the partial scan mode.

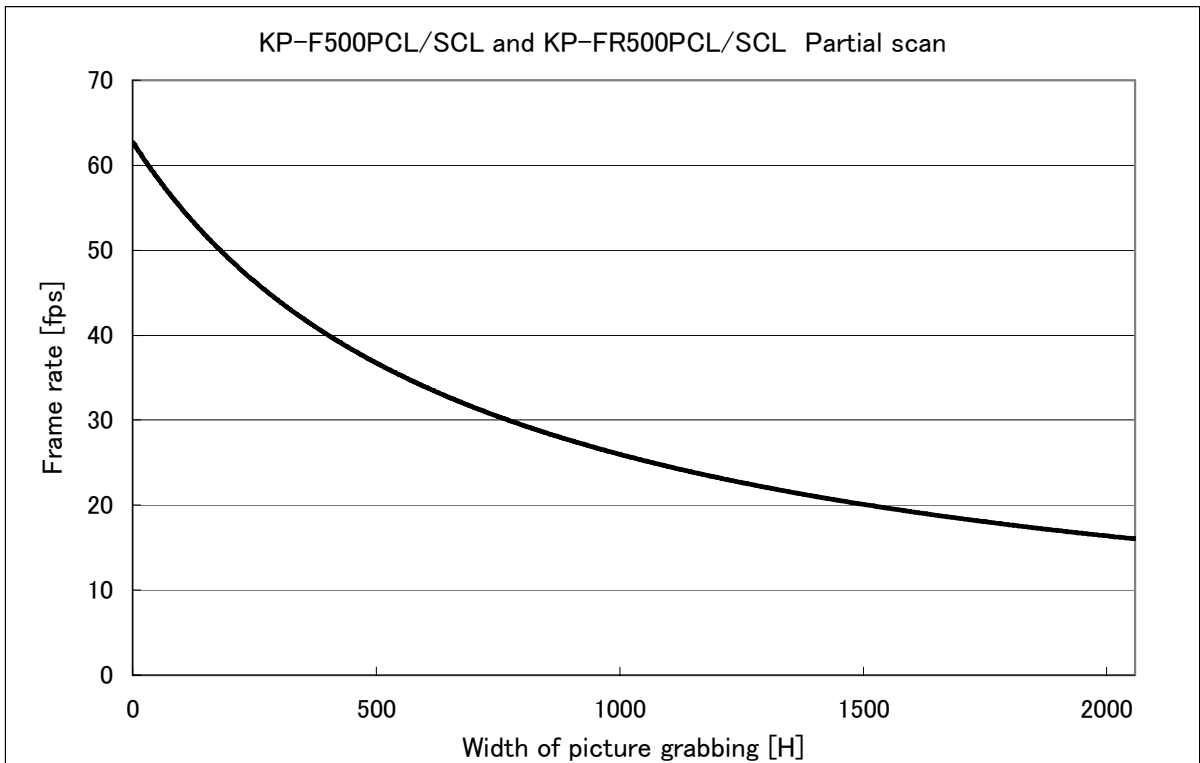

Note: Please ask your sales representative more detail information about frame rate in each width of picture grabbing.

2. Fixed shutter mode

When external trigger signal is high active, after the trigger signal rise, exposure is start. The exposure time is set by the camera electronic shutter speed. The video output is obtained immediately after the end of fixed exposure. The strobe signal start/end can be set to shutter time.

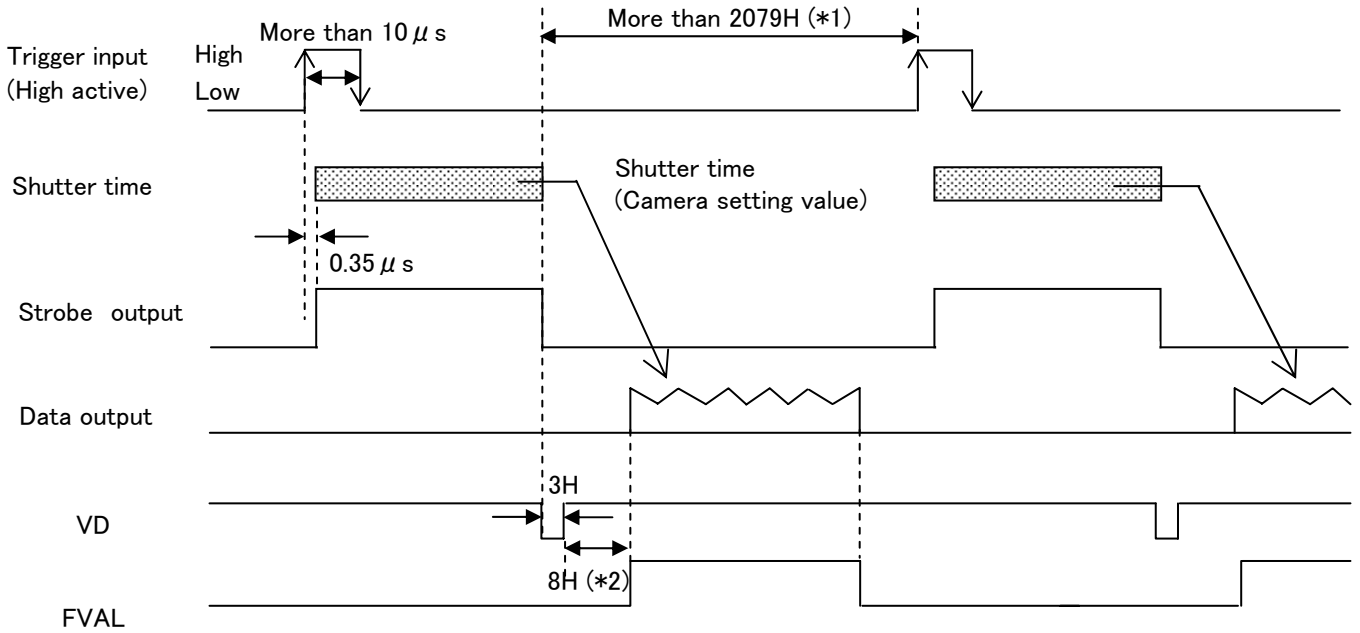

Ex.

Width	More Than ...
1H	15.9 ms
100H	18.2 ms
1000H	38.5 ms
2000H	60.1 ms

*1: When partial scan, variable by setting (refer to left table).

*2: When partial scan, variable by start position of picture grabbing.
4H when vertical two pixel addition.

3. ONE trigger mode

When external trigger signal is high active, after the trigger signal rise, exposure is start. At the trigger signal falling edge, the internal VD signal is reset and the video data are transmitted. The trigger signal width equals the exposure time.

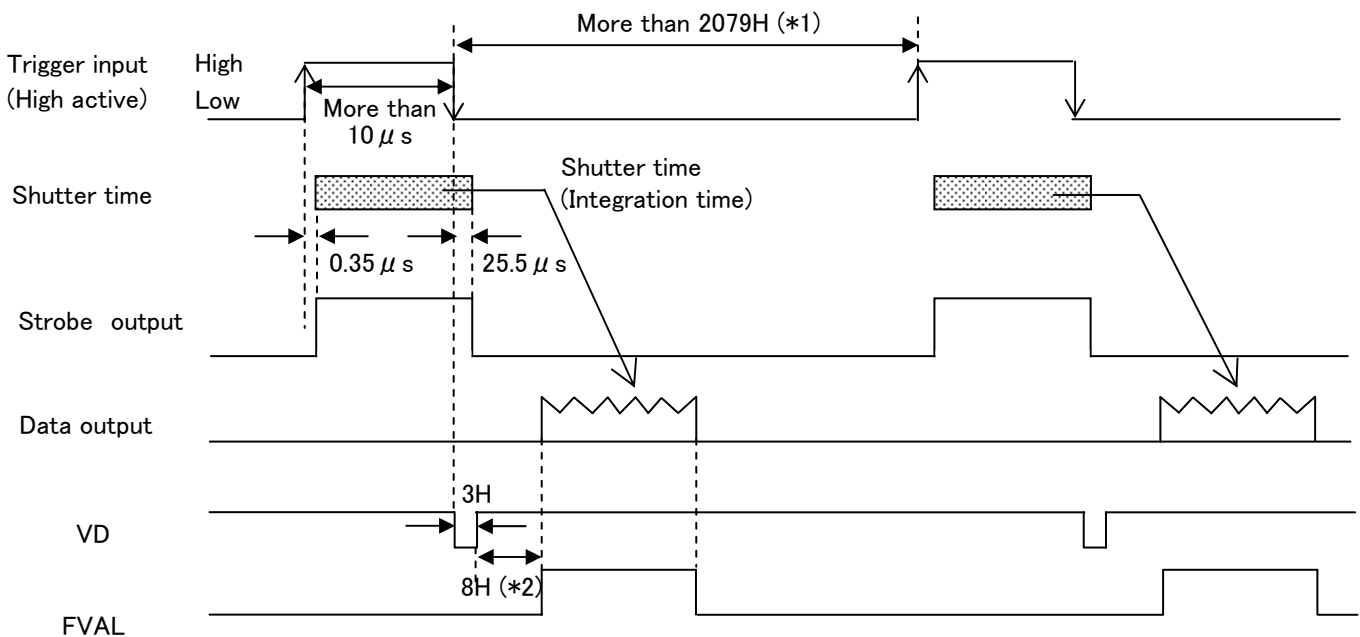

Ex.

Width	More Than ...
1H	15.9 ms
100H	18.2 ms
1000H	38.5 ms
2000H	60.1 ms

*1: When partial scan, variable by setting (refer to left table).

*2: When partial scan, variable by start position of picture grabbing.
4H when vertical two pixel addition.

4. VD reset

When external VD pulse is inputted, internal HD/VD is reset.

External VD specification: 16.00 Hz or less

*Note: When external VD of 16.00 Hz or more is input, electronic shutter has an equation between external VD and 16.00 Hz.

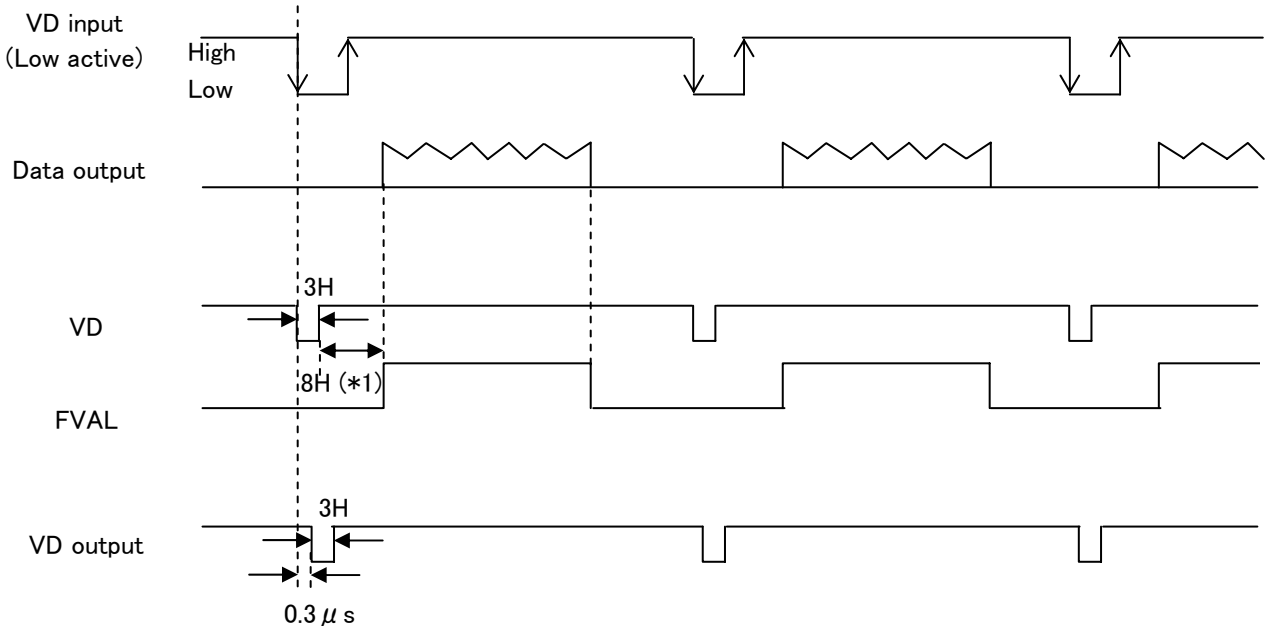

*1 : When partial scan, variable by start position of picture grabbing.
4H when vertical two pixel addition.

Input / Output signal

1. Input signal

The level of the trigger signal input to KP-F500PCL/SCL and KP-FR500PCL/SCL is as follows.

(1) Input from CameraLink cable

LVDS level.

(2) Input from 12-pin connector

High level : +2.5 to +5.0 V

Low level : 0 to +0.3 V

2. Output signal

The level of the trigger signal output from KP-F500PCL/SCL and KP-FR500PCL/SCL is as follows.

High level : +5V

Low level : 0V

Spectral response

Spectral response of KP-F500PCL/SCL and KP-FR500PCL/SCL are showing.

1. KP-F500PCL/SCL

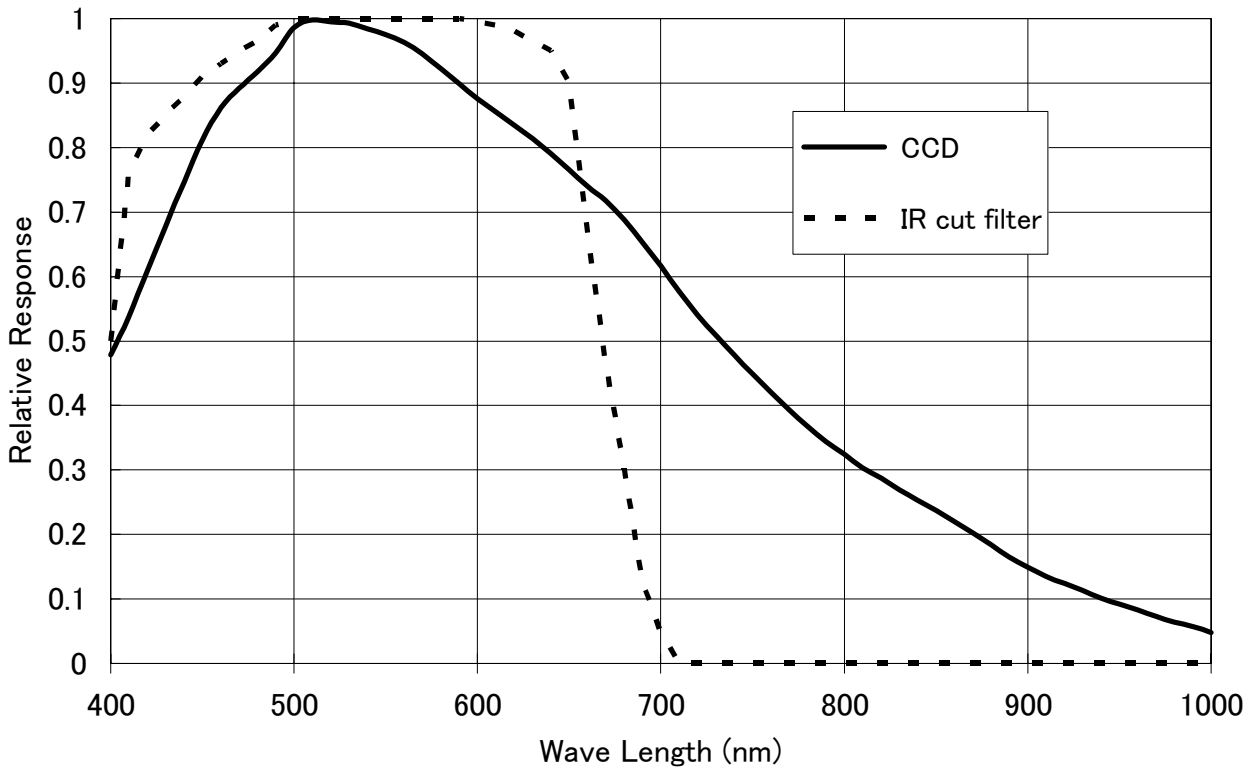

2. KP-FR500PCL/SCL

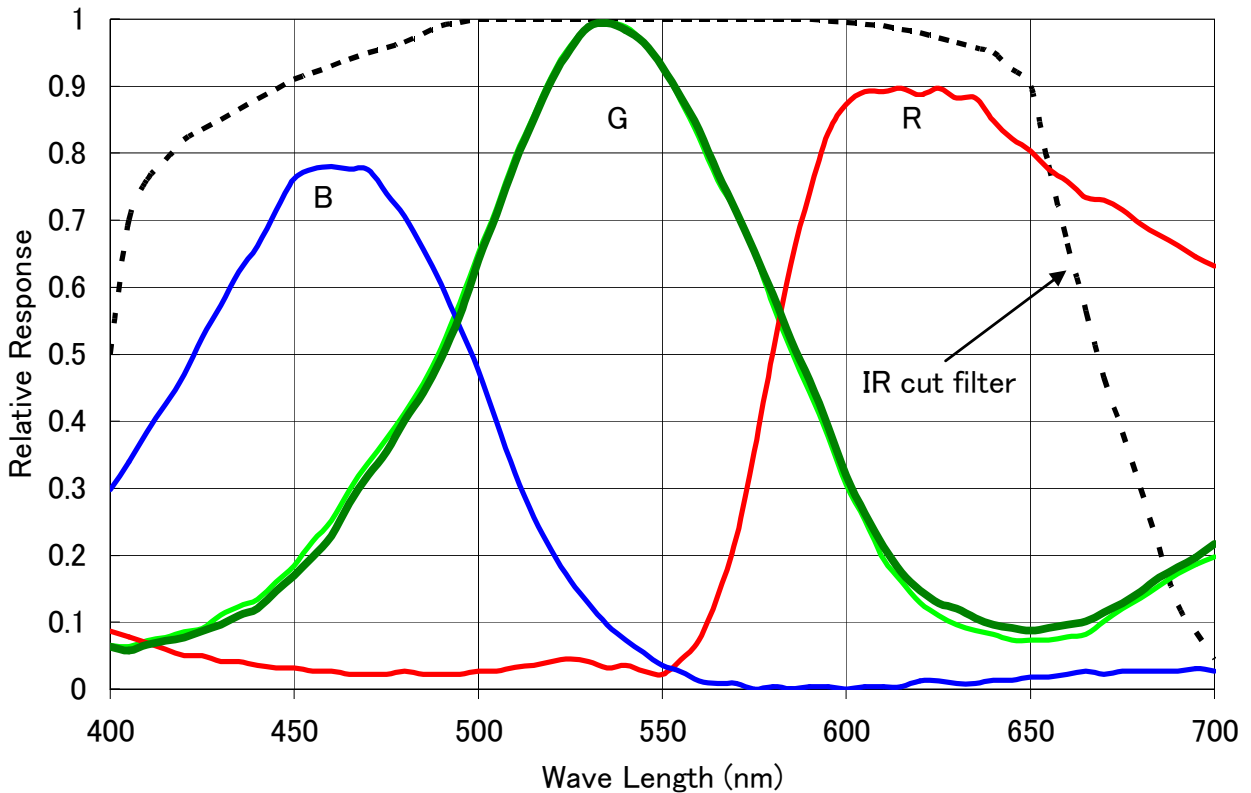

Specifications

Specifications of KP-F500PCL/SCL and KP-FR500PCL/SCL are showing.

	KP-F500PCL/SCL	KP-FR500PCL/SCL
1) Imaging device	2/3-inch interline CCD	
Total pixels	2536 (H) x 2068 (V)	
Effective pixels	2456 (H) x 2058 (V)	
Active pixels	2448 (H) x 2050 (V)	
Pixel pitch	3.45 μ m (H) x 3.45 μ m (V)	
Color filter	RGB primary color mosaic filter	
2) Image area	8.47mm (H) x 7.10mm (V)	
3) Scanning system	Progressive scan	
4) Aspect	5:4	
5) Frame rate	16 frame per second	
6) Horizontal drive frequency	64.000 MHz	
7) Horizontal scanning frequency	33.264 kHz	
8) Vertical scanning frequency	16.00 Hz	
9) Synchronization	Internal	
10) Lens mount	C mount	
11) Frange back	17.526mm (no adjustment)	
12) Video output	Digital output (CameraLink) Base configuration: 64MHz / Medium configuration: 32MHz (Note: Maximum digital out cable length is 10 meters.)	
13) VD reset input	Less than 16.00 Hz	
14) Resolution	2000 TV lines (Horizontal / Vertical)	
15) Sensitivity	400lx, F5.6 3200K	2000lx, F8 3200K
16) Minimum illumination	1.0lx, F1.4, Gain MAX, without IR cut filter	15lx, F1.4, Gain MAX
17) S/N	48dB	
18) Electronic shutter	Preset: 1/50000, 1/10000, 1/2000, 1/1000, 1/250, 1/100, /60, and 1/16 second Variable: 1/100000 to 10 second	
19) Gamma correction	$\gamma=1$	
20) Frame on demand		
Mode	OFF (Normal mode), Fixed shutter mode, ONE trigger, VD reset	
Trigger input	From CameraLink connector or DCIN 12pin connector	
21) Partial scan	Selectable start position and width of picture grabbing in 1H step	
22) Remote control		
Control system	Start-stop synchronization system	
Control items	TRIGGER, OUTPUT SIGNAL, SHUTTER SPEED, CONFIGURATION, DATA BIT, VD/FVAL, HD/LVAL/LVAL2, GAIN, BLACK LEVEL, VERTICAL 2 PIXEL ADDITION (only KP-F500PCL/SCL), PARTIAL SCAN	
23) Power supply	DC12V \pm 1V	
24) Power consumption		
Normal mode	Approx. 310mA (Approx. 3.7W)	
Partial scan	MAX Approx. 390mA (Approx. 4.7W) when WIDTH: 1H	
25) Ambient temperature		
Operating	0°C to +40°C / less than RH 90%	
Storage	-10°C to +50°C / less than RH 70%	
26) Vibration endurance	10 to 55Hz (2.37 to 71.7 m/s ²), sweep: 1 minutes, XYZ, 30minutes	
27) Shock endurance	490.3m/ s ² (vertical, horizontal, once each faze)	
28) Dimensions	44(W) x 44(H) x 41(D) mm	
29) Mass	Approx. 110g	
30) Standard compositions	Camera, CD-ROM (Operation manual, Control software), Composition table	

Dimensions

MASS : APPROX 110 g

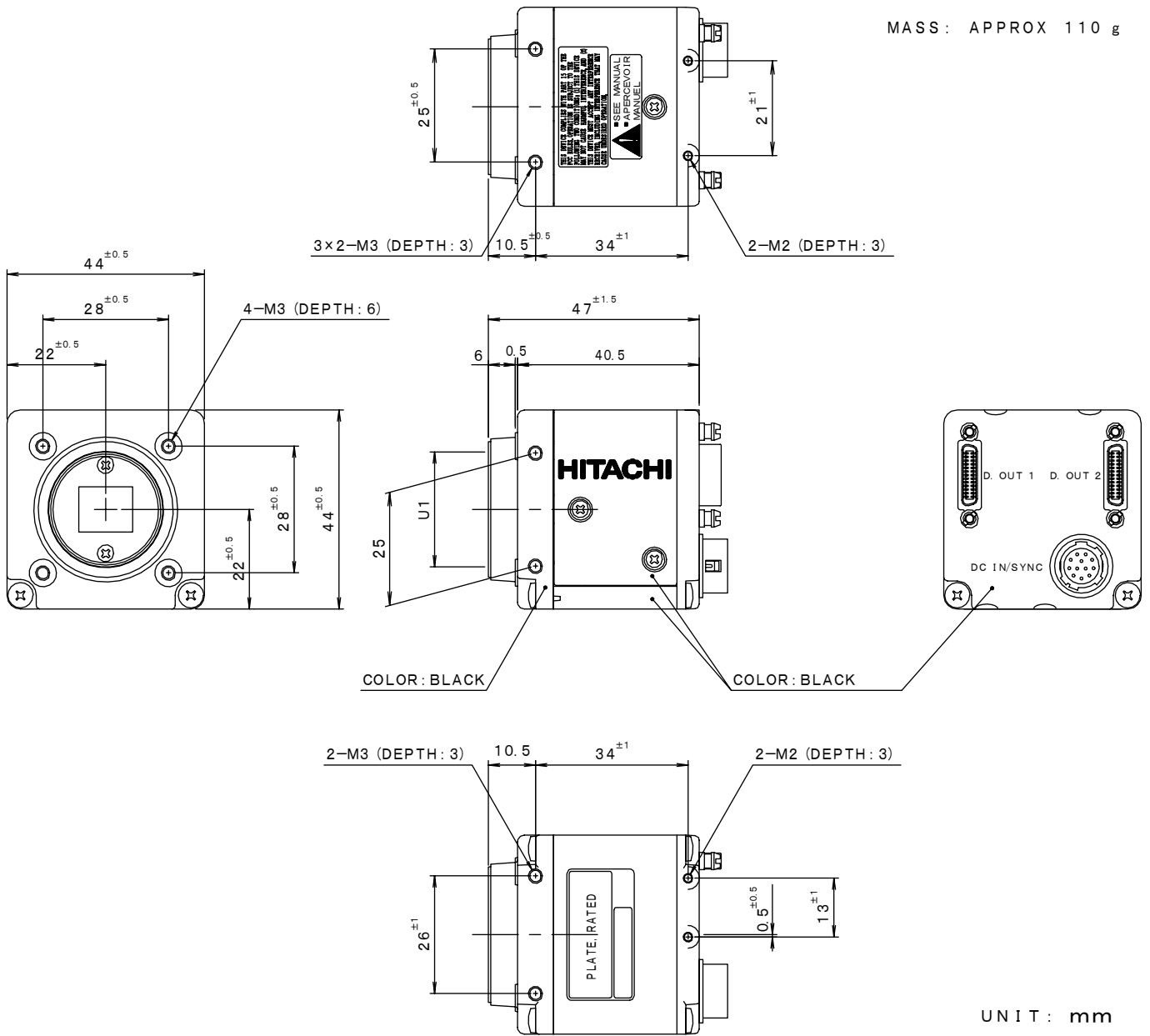

UNIT : mm

About CD-ROM

Attached CD-ROM has the following composition.

- KP-F500_FR500P(S)CL_OperationManual(E)/(J).pdf : The operation manual of camera in English and Japanese.
- KP-F500_FR500P(S)CL_ControlManual(E)/(J).pdf : The operation manual of control software in English and Japanese.
- KP-F500_FR500P(S)CL.exe : The control software.

Note:

- ① The included control software within CD-ROM operate only in Windows 98/Me/NT/2000/XP.
- ② The control software may not operate normal when it is used for the other camera, because software for Hitachi Kokusai Electric.
- ③ Hitachi Kokusai Electric Inc. does not guarantee regarding the faulty, damage of the hardware and also software of the customer by a driver and also viewer software.

Hitachi Kokusai Electric Inc.

UDX Akihabara Bldg.

14-1 Sotokanda 4-choume, Chiyoda-ku, Tokyo 101-8980, Japan

Phone: (03) 5209-5931, Fax: (03) 5209-6119

URL: <http://www.h-kokusai.com>

Beijing Office

Beijing Fortune Building 5, Dong San Huan Bei-lu, Chao Yang District, Beijing, 100029 China

Phone: +86(0) 10-6590-8755/8756, Fax: +86(0) 10-6590-8757

Hitachi Kokusai Electric America, LTD.

Headquarters and : 150 Crossways Park Drive, Woodbury, New York 11797, U.S.A.

Northeast Office Phone: (+1) 516-921-7200, Fax: (+1) 516-496-3718

West Office : 371 Van Ness Way, Suite 120 Torrance, CA, 90501, U.S.A.

Phone: (+1) 310-328-6166, Fax: (+1) 310-328-6252

Midwest Sales : Phone: (+1) 330-334-4115, Fax: (+1) 516-496-3718

Service (+1) 989-345-5379

South Sales : Service (+1) 256-774-3777

Parts Center : phone (+1) 516-682-4435, Fax: (+1) 516-921-0993

Latin Sales : phone (+1) 519-682-4420, Fax: (+1) 516-496-3718

URL: <http://www.hdal.com/>

Hitachi Kokusai Electric Europe GmbH

Head Office : Weiskircher Strasse 88, Jugesheim D-63110 Rodgau, Germany

Phone: +49(0) 6106-6992-0, Fax: +49(0) 6106-1690-6

URL: <http://www.hitachi-ke-eu.com/>

Hitachi Kokusai Electric U.K. Ltd.

Head Office : Windsor house, Britannia Road, Waltham Cross, Hertfordshire EN8 7NX, United Kingdom

Phone: +44(0) 845-121-2177, Fax: +44(0) 845-121-2180

URL: <http://www.hitachi-ke-eu.com/>