

HITACHI

KP-F80
**Progressive Scan
B/W CCD Camera
Operation Guide**

Table of Contents

1. General	1
2. Composition	1
3. Specifications	1
4. Adjustment	3
5. Timing chart	5
6. External view	9
7. External sync	10
8. Connect cables	11
9. Optical system	12
10. Optional	13
11. Notes to users	16
Attachment : Spectral sensitivity characteristic	18

1. General

The Hitachi KP-F80 are a high performance self-contained black and white CCD camera suited for a wide variety of general purpose and specialized applications. The charge coupled device (CCD) imaging element is 1/3-inch size progressive scanning with independent readout of all picture elements (pixels).

In addition to high resolution and sensitivity, a broad array of functions, including multi-step electronic shutter, HD/VD external sync, frame on demand and many more contribute to versatility that meets a wide range of needs.

The square pixel CCD also renders an image appropriate for image processing systems.

2. Composition

- 1) Black and white camera (With IR cut filter) 1
- 2) Operation manual 1

3. Specifications

- 1) Imaging device
Total pixels
Effective pixels
Pixel size
 - 2) Sensing area
 - 3) Scanning system
 - 4) Hor. scanning frequency
 - 5) Vert. scanning frequency
 - 6) Sync system
 - 7) External sync input
- | |
|---|
| 1/3 inch progressive scan interline CCD |
| 1077(H) × 788(V) |
| 1034(H) × 779(V) |
| 4.65(H) × 4.65(V)μm |
| 4.81(H) × 3.62(V)mm |
| Progressive scan |
| 23.622kHz |
| 29.83 Hz |
| Internal/external, automatic selection |
| HD & VD : 5V DC negative |
| Input impedance : 75Ω or High impedance |
| Frequency deviation : ±1% |

8) Video output	1.0 Vp-p, 75Ω, unbalanced Video component : 0.7 Vp-p Sync component : 0.3 Vp-p negative
9) Horizontal Resolution	800 TV lines
10) Signal to noise ratio	54 dB
11) Electronic shutter	External switch settings for off (standard exposure), 1/50000s to 1/250s Factory setting is off.
12) Gamma correction	1
13) Gain control	Manual gain control. Factory setting is Minimum.
14) Frame on demand	External switch. Selectable One trigger, fixed shutter and Reset control. (Partial scan : option) Factory setting is off.
15) Power supply voltage	12 ± 1 VDC
16) Power consumption	Approx. 2.2 W
17) Ambient temperature and humidity	Operating -10 to 50 RH less than 90 % Storage -20 to 60 RH less than 70 %

Caution: For continued stable operation, the camera should be used under 40 °C or less when it is used continuously for extended period of time.

18) Anti-vibration	98m/s ² (10 to 60Hz, amplitude: 0.98mm constant, 60 to 200Hz, amplitude: variable) (10 to 200Hz, sweep:1 min., XYZ, 30 min.)
19) Resistance to shock	686m/s ² (Drop test, once each top, bottom, left and right)
20) Dimensions	29(W) × 29(H) × 38.5(L)mm
21) Mass	55g approx.

4. Adjustment

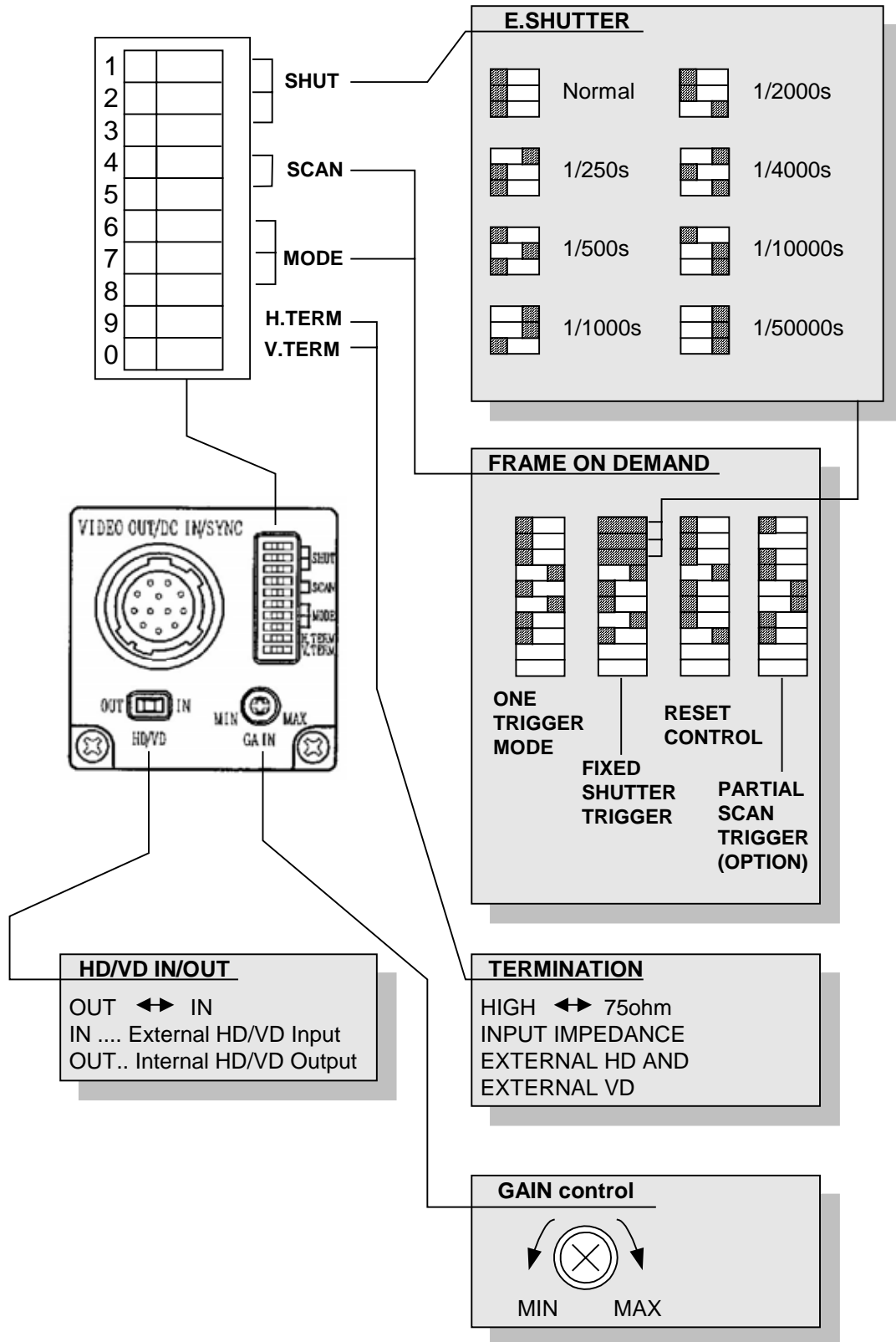

4.Adjustment

VIDEO OUT/DC IN/SYNC CN
VIDEO OUTPUT
DC IN: DC12V(11 to 13V)
EXT.HD, EXT.VD and
Trigger input

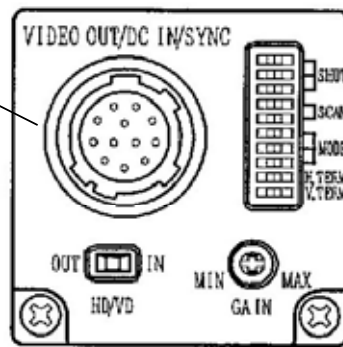

PIN NO.	Internal sync mode	External sync mode					JU-F30 BNC
		HD/VD	Frame on demand				
			ONE trigger	Fixed shutter	Reset control	Partial(OPTION)	
1	GND	GND	GND	GND	GND	GND	(GND)
2	+12V	+12V	+12V	+12V	+12V	+12V	(+12V)
3	GND(Vout)	GND(Vout)	GND(Vout)	GND(Vout)	GND(Vout)	GND(Vout)	GND
4	Vout	Vout	Vout	Vout	Vout	Vout	VIDEO1
5	GND	GND(HD)	GND(HD)	GND(HD)	GND(HD)	GND(HD)	(GND)
6	-	HD IN/OUT	HD IN/OUT	HD IN/OUT	HD IN/OUT	(HD IN/OUT)	HD
7	-	VD IN/OUT	Trigger	Trigger	Trigger/VD	Trigger	VD
8	GND	GND	GND	GND	GND	GND	(GND)
9	NC	NC	NC	NC	NC	NC	VIDEO2
10	WEN	WEN	WEN	WEN	WEN	WEN	WEN
11	-	-	-	-	Trigger B	-	-
12	GND	GND(VD)	GND(Trig)	GND(Trig)	GND(Trig)	GND(Trig)	(GND)

5 Timing chart

KP-F80 CCD OUTPUT WAVE TIMING CHART

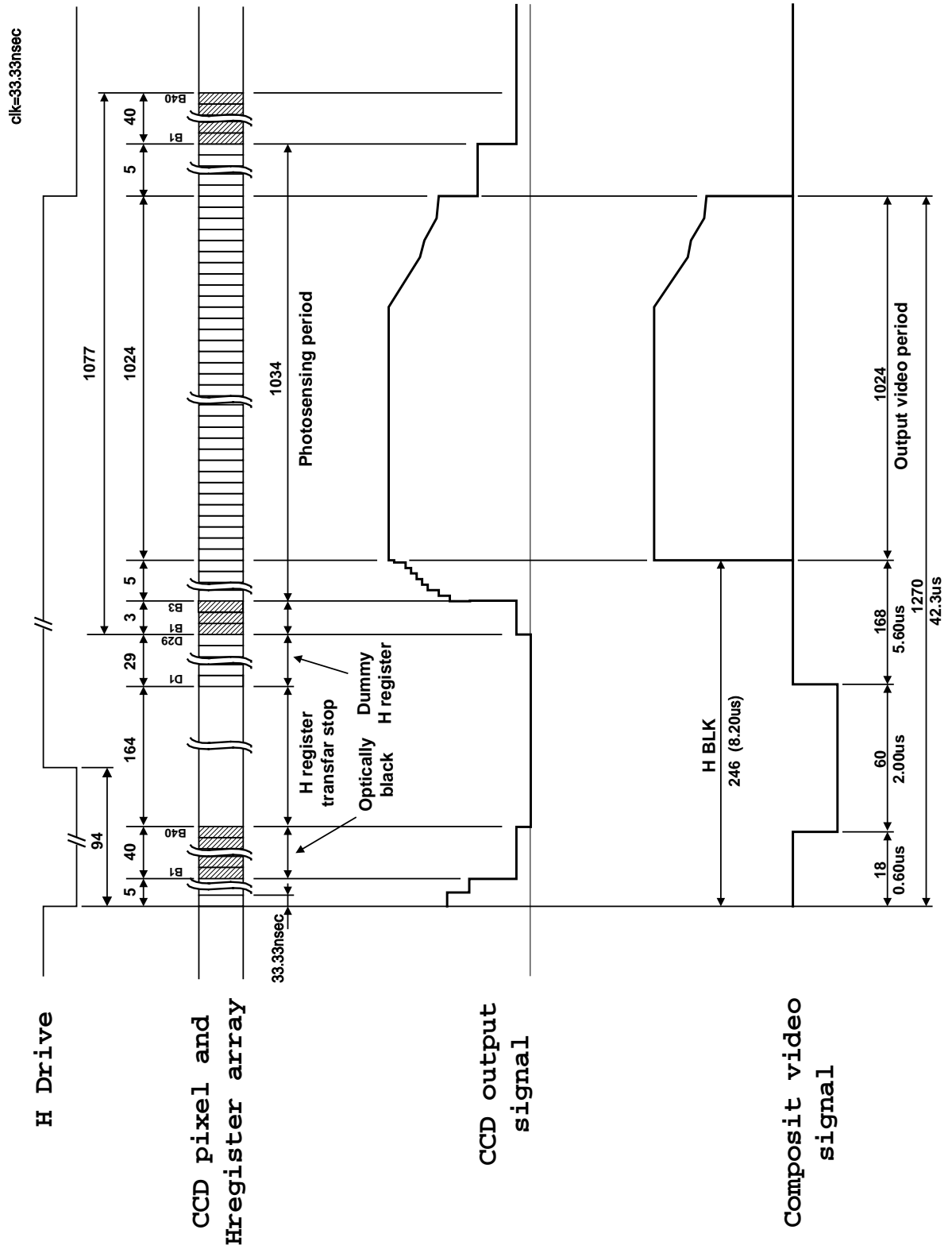

KP-F80 Timing chart

1H = 42.33uS

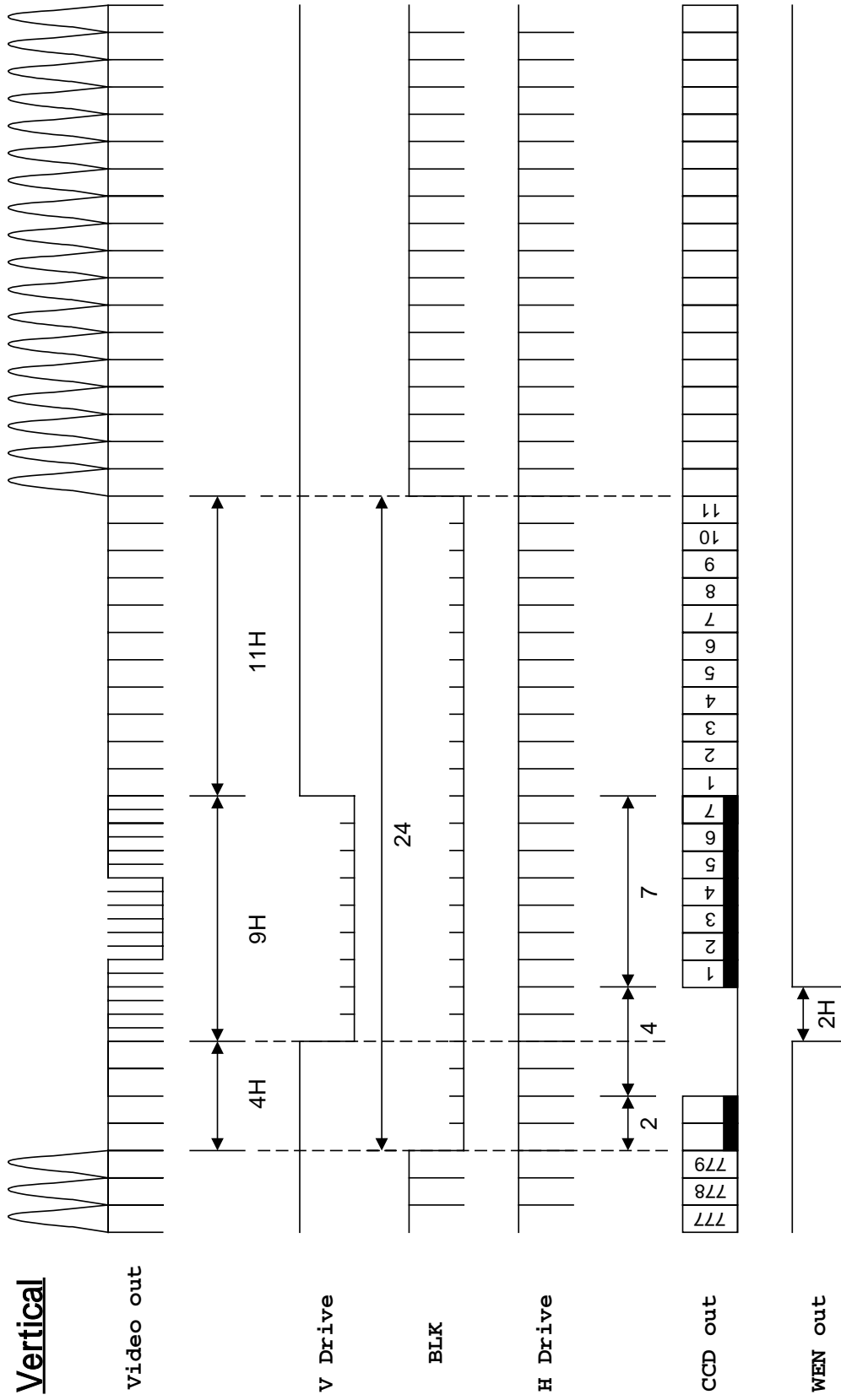

KP-F80
Frame on demand function

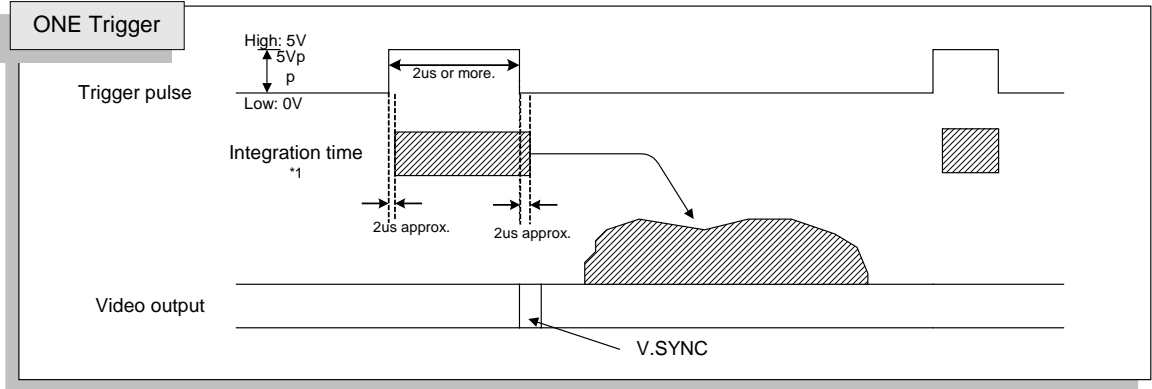

Trigger pulseAsynchronous

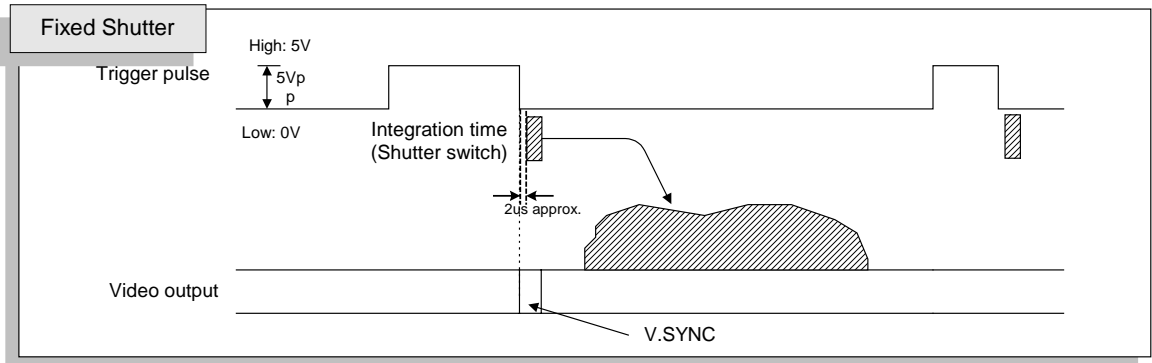

Trigger pulseLatch in internal HD

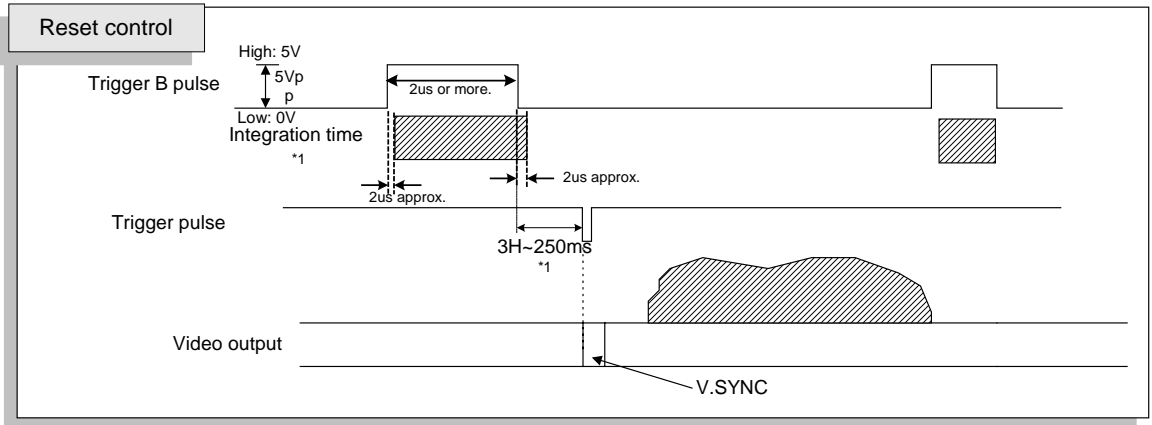

Trigger B pulseAsynchronous
Trigger pulseLatch in internal HD

NOTE: The latch and non-latch can be changed.

*1 Please inquire.

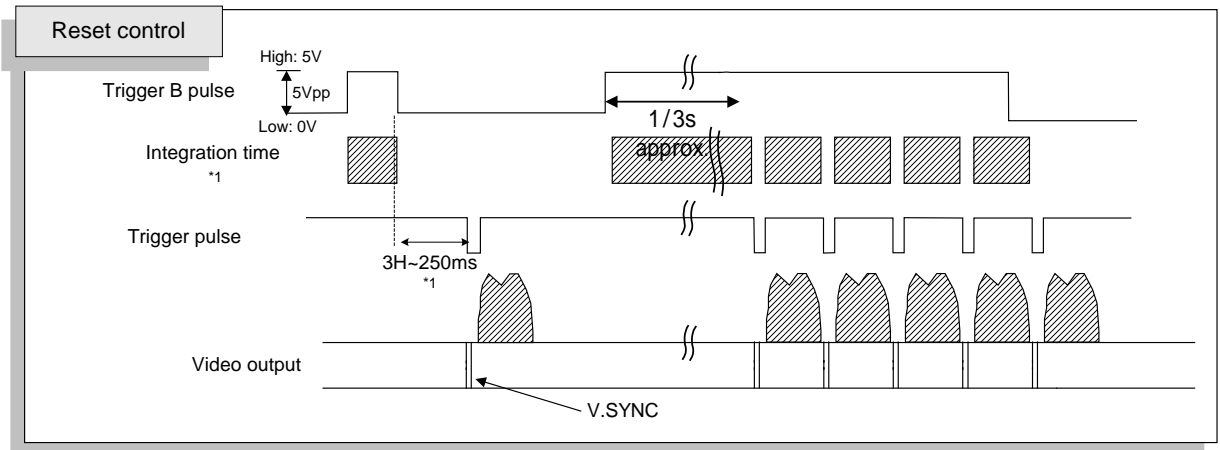

Special function of reset control Trigger

The camera shifts to the output of a normal mode (continuous output) when Trigger B signal passes about 1/3 seconds in the state of High.
 (The image is output by inputting the Trigger at the VD cycle for this period.)
 It returns to the Trigger mode if Trigger B signal becomes Low.
 However, after becoming Low Trigger B, the period of 50ms becomes a Trigger signal input prohibition period.

6 External view

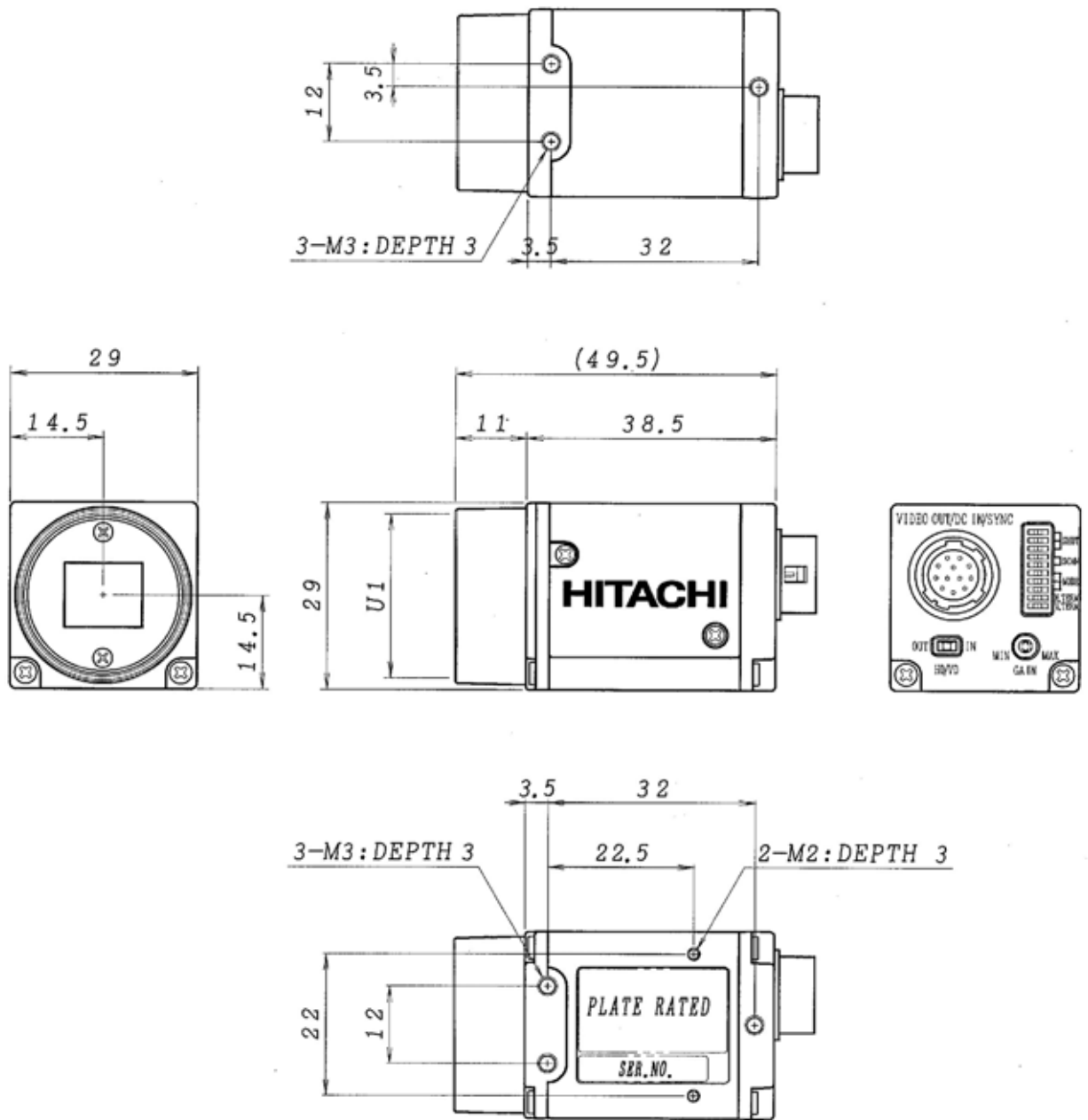

Dimensions

7. External sync

- Horizontal and vertical drive signal inputs
HD $f(H) = 23.622 \text{ kHz} \pm 1 \%$
VD $f(V) = 29.83 \text{ Hz}$
- Input level
HD 4 to 6 VDC negative
VD 4 to 6 VDC negative
Trigger 4 to 6 VDC
- Input impedance 75ohm or High impedance (10kohm)
Trigger B(Pin 11) 1kohm

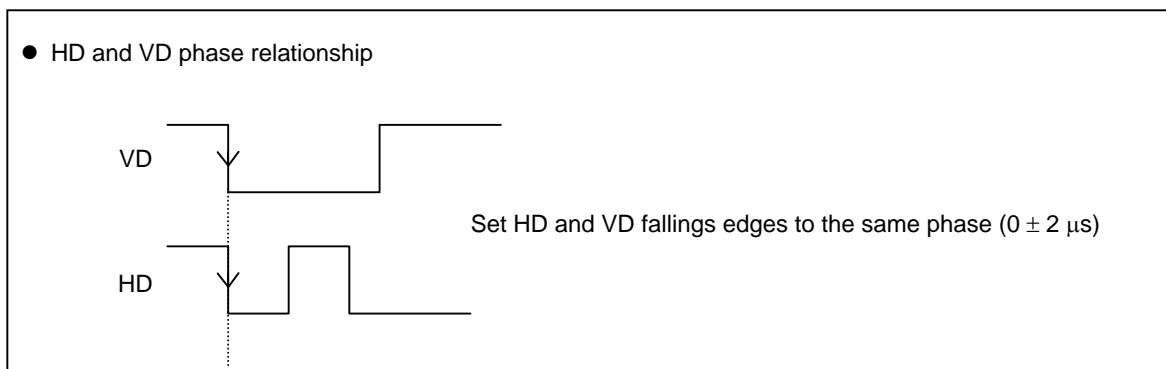
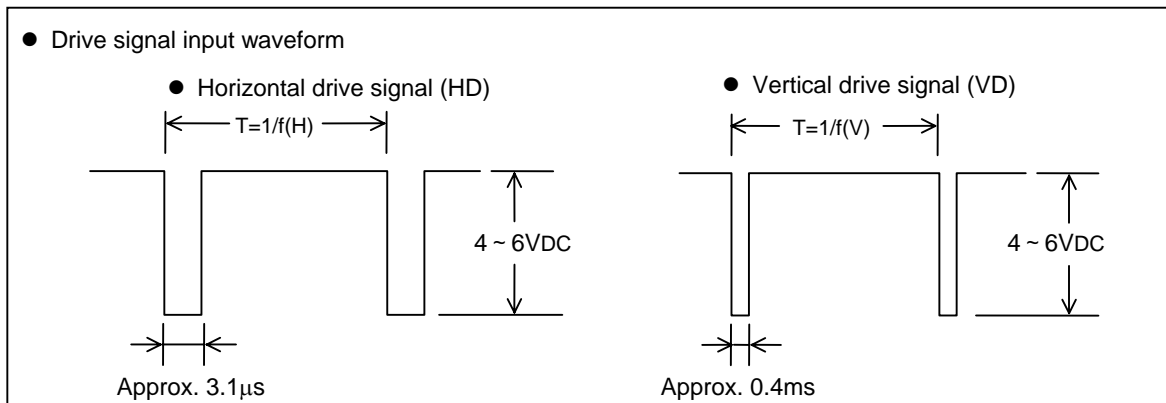

8. Connect cables

Connection of options

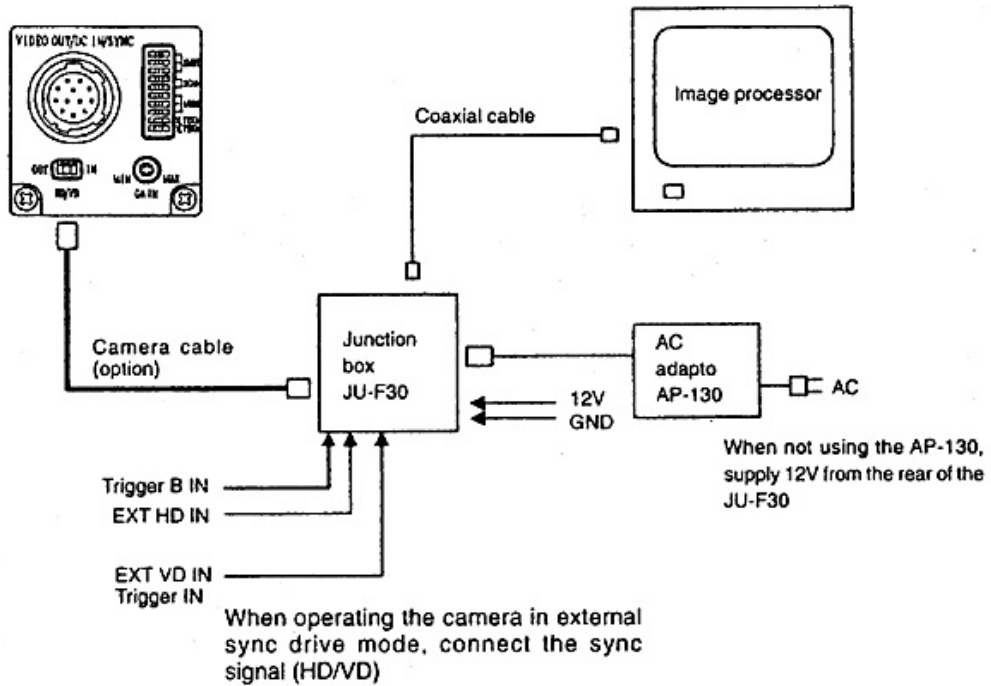

9. Optical system

1) Flange focal

- Image size: 1/3-inch
- The flange focal distance is 17.526mm(in air).
- Flange focal distance cannot be adjusted.

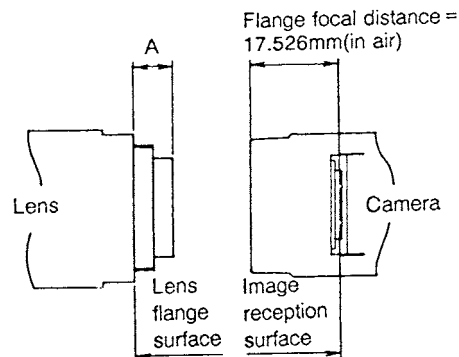

Note:

Select such a lens as the length (A) from the flange surface of the lens to the end of the screw side is 8mm or less.

2) Optical filler

This camera is provided with an IR cut filter.

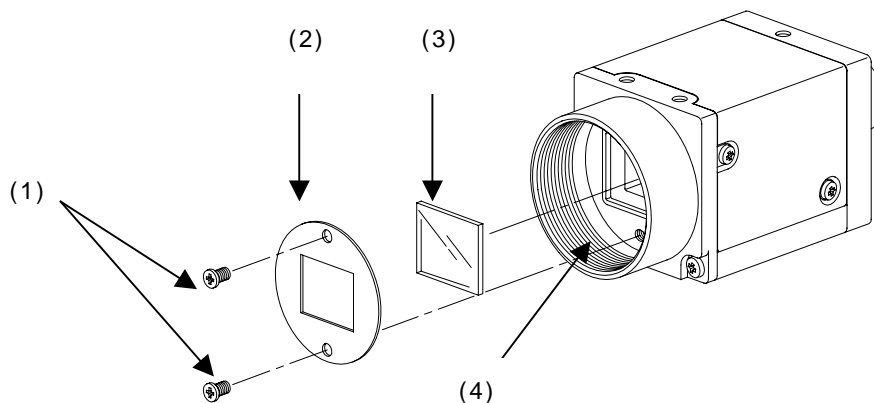

IR cut filter removal

- Remove two screws (1) shown in Fig., and filter holder (2) will come off.
- Remove the IR cut filter (3) from filter frame (4).
- Reinstall and secure filter holder (2) with two screws (1).

Caution

Prior to removing the optical filter, be sure to turn off the power.

IR cut filter IRC650
 Dimensions: 14 x 12 x 1.0t
 Part code: XMD0006

External view

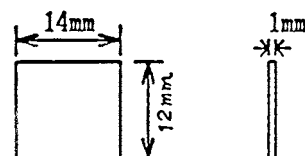

* The flange focal point shortens by about 0.3mm when IR cutting filter is removed.

We will recommend the dummy glass of the optional to be installed.

10. Optional

1) Tripod adaptor

TA-F30 (23885AX)

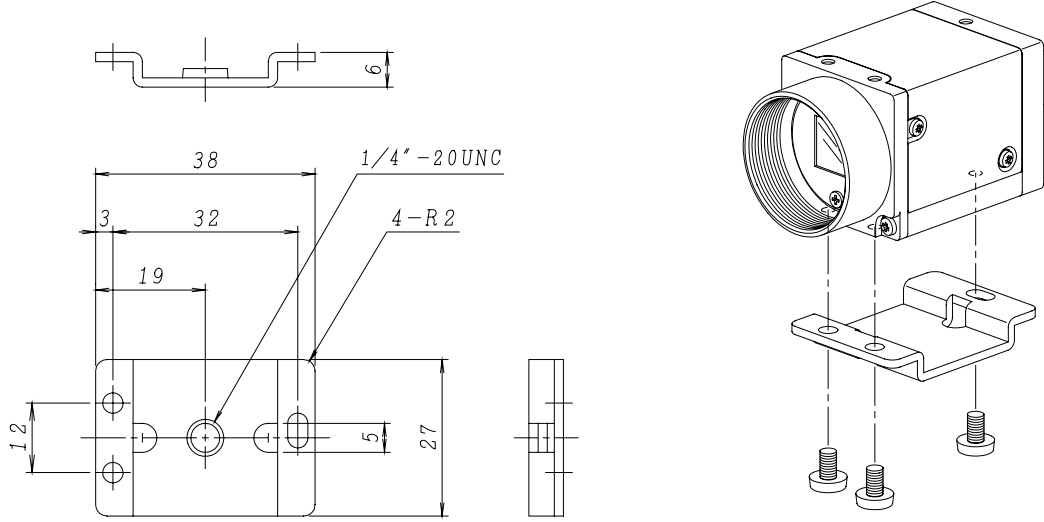

2) 12-pin plug

HR10A-10P-12S(01) Product code: 23810AX

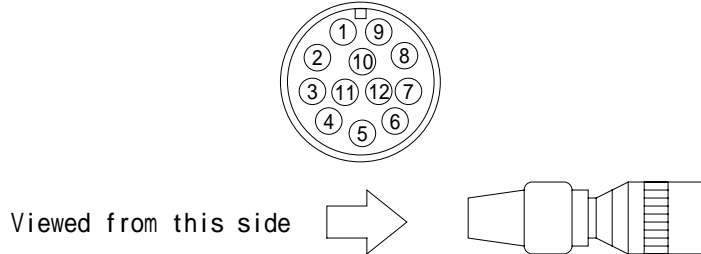

3) Junction box **JU-F30** Product code: 23884AX

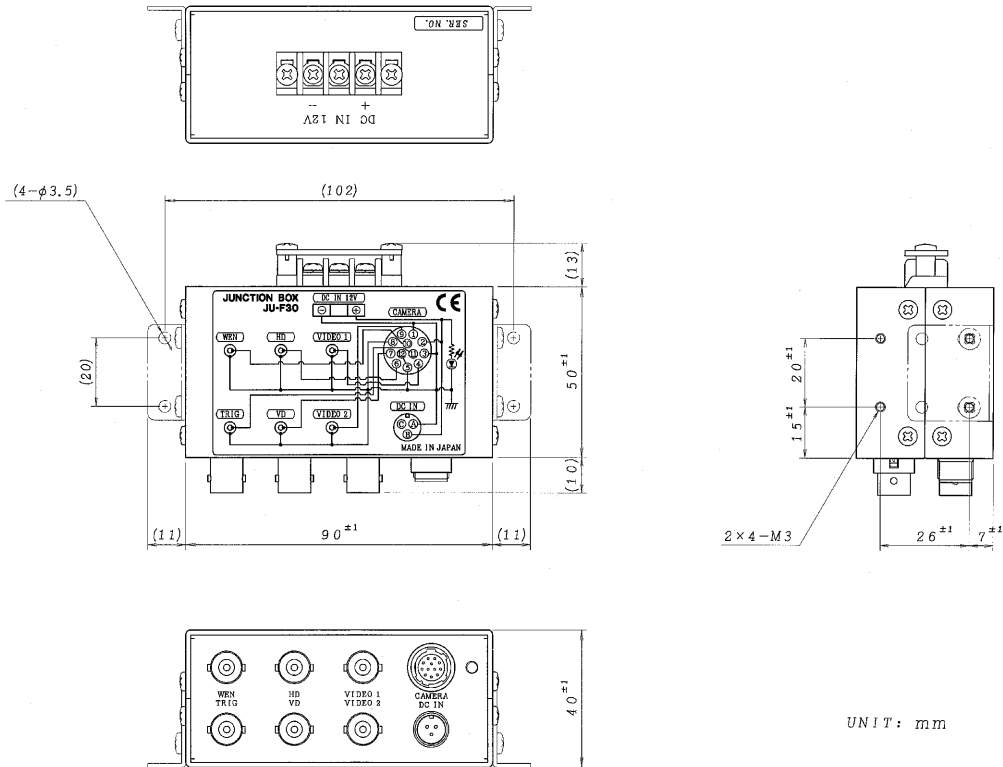

4) Dummy glass **ARC1214** Parts code: XMD0009

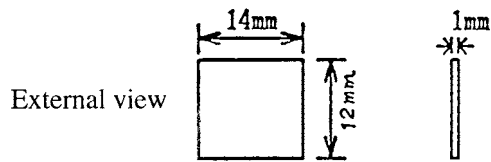

5) Camera cables

	Mould type	Assy type	Shielded type
2m	C-201KSM(23861AX)	C-201KS(23856AX)	C-201KSS(23872AX)
5m	C-501KSM(23862AX)	C-501KS(23857AX)	C-501KSS(23873AX)
10m	C-102KSM(23863AX)	C-102KS(23858AX)	C-102KSS(23874AX)

Specify assembly or shielded type at time of order.

(): Product code

We will recommend the camera cable of the shield type when using it in the sphere of CE.

10. Optional

- Voltage drop due to a cable is about 0.01V per meter.
- The H phase delays by about 5ns per meter.

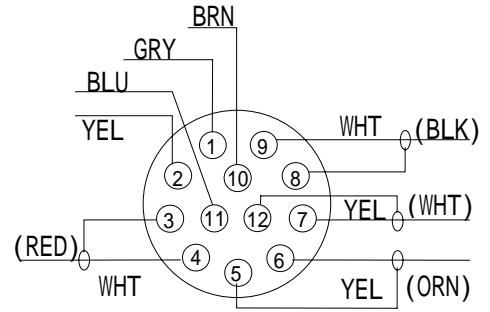

- Attenuation of video signal due to used cable
 Attenuation due to optional cables C-501KSM and C-102KSM is shown below.
 Attenuation is proportionate to the cable length.
 Characteristic impedance is kept at constant even at cable length change.

	Cable length	Attenuation at 4MHz	Attenuation at 7MHz	Attenuation at 12MHz
		50dB/Km	70dB/Km	90dB/Km
Attenuation due to cable length(dB)	1m	0.05	0.07	0.09
	2m	0.1	0.14	0.18
	5m	0.25	0.35	0.45
	10m	0.5	0.7	0.9

The video bandwidth obtained by the KP-F80 is up to approximately 12.5 MHz.

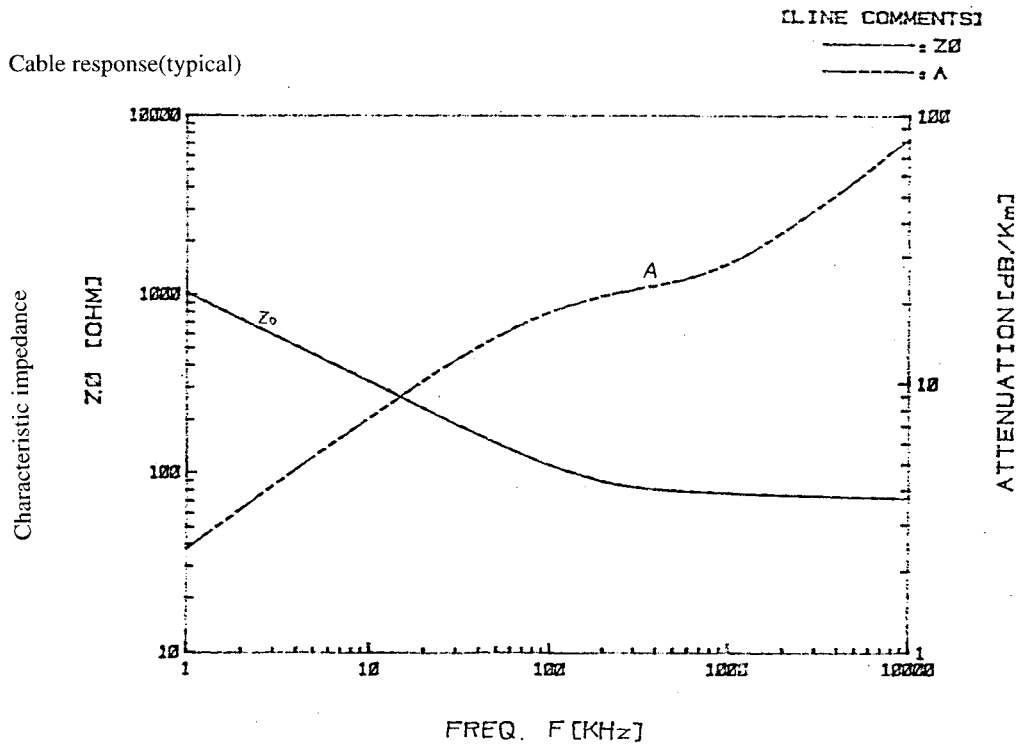

11. Notes to users

◆ Power supply

- Connect a 12V DC voltage (11 to 13V) from an external regulated DC power supply.
- Use a stable power supply without ripple and noise.
- Prior to turning on the power switch , check that the polarities of the power cable are correct , referring to the connection diagram

◆ To protect CCD (sensor)

- Do not touch the glass surface of the CCD sensor to avoid deterioration in picture quality due to dirt and scratches.
- If the glass surface of the sensor should become dusty or dirty , remove dust or dirt carefully with a cotton-tipped applicator. Do not wipe the surface with dry cloth or paper tissue to avoid possible damage to the glass surface by static electricity.

◆ Protection of camera

- Do not use or store the camera under direct sunlight , at a place exposed to rain or snow , or at a place where flammable or corrosive gas is present.
- When housing the camera in a camera case , use the utmost care regarding rise of internal temperature.

When casing the camera , the temperature normally rises by 10 to 20 , compared with the outside air temperature. The camera operates in the temperature range from -5 to 45 . If the camera is used or left in high temperature environment for hours , the life of the camera may be shortened.

- Do not drop the camera. Do not apply strong shock or vibration to the camera.
- Before connecting or disconnecting a connector , turn off the camera and be sure to hold connector body to connect or disconnect the connector.

◆ Camera arrangement

- Mutual interference noise can occur if multiple cameras are arranged in close proximity. Separate the cameras to the extent possible.

When camera units are installed directly into other equipment , external noise can prevent a normal picture. In such cases , shield the camera units.

The camera can be damaged by static electricity. Use ample care when installing and arranging.

◆ Auto electric shutter

- In regions using 50 Hz power line frequency , flicker can appear on the monitor screen from light sources such as fluorescent or mercury. In such cases , release the auto electronic shutter.

◆ Phenomena inherent to CCD imaging device

Following are phenomena inherent to a CCD imaging device , and not defects.

- Smear and blooming

When strong light (lamp , fluorescent lamp , reflected light , etc.) is shot , pale bands are displayed vertically above and below the light.

In this case , change the angle of the camera so that such strong light does not enter the camera through the lens.

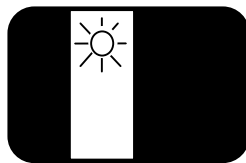

- Fixed pattern noise

When the camera is operated in a high temperature , fixed pattern noise may appear on the entire screen.

The higher the sensitivity of camera , the more this fixed pattern noise appears.

- Moire

When fine patterns are shot , moire may be displayed.

- The CE mark is required when exporting to Europe. Obtain the necessary authorization for the customer's system. Enclose the camera in a shielded case and use shielded cable.

Spectral sensitivity (typical example)

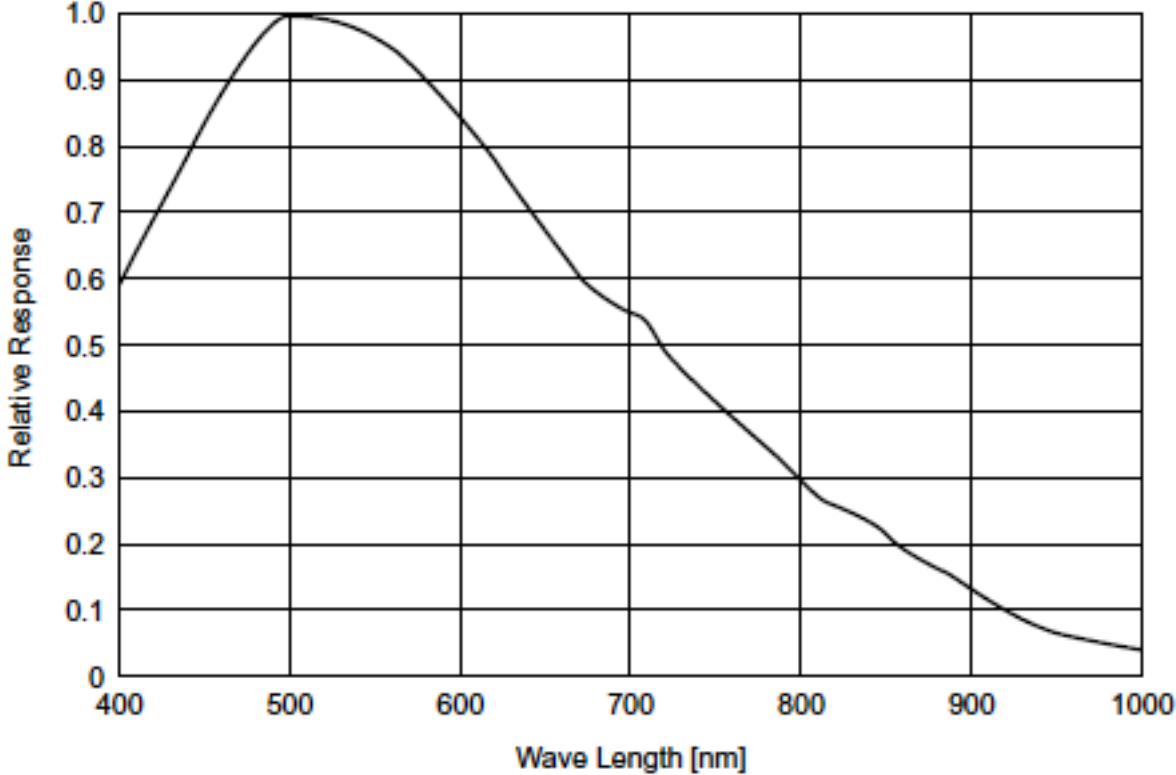

Caution	
---------	--

The specifications of this equipment are subject to change without notice for improvement. Prior to placing your order , be sure to confirm that these specifications are the latest ones. Hitachi Denshi guarantee that the equipment shipped from our factory conforms to the Hitachi Denshi's standard warranty conditions and perform quality control within the range necessary to perform the warranty.

Warranty and After-sales Service	
----------------------------------	--

- (1) The guarantee period is one year after the date of purchase. However , the defects due to erroneous use or intentional act are excluded.
- (2) As the defect after expiration of the guarantee period , Hitachi Denshi will repair the equipment if the intended function is restored by the repair work , and the cost is changed to a customer.
- (3) Hitachi Denshi is not liable for the losses caused when the equipment is used in a system used for business trades , production process , medical fields , crime prevention applications , etc.
- (4) The parts used in the equipment have their respective lives. The lives of such parts will be shortened under the environments of high temperature or high humidity. When the stable operation is required for a long time , it is recommended to perform periodical maintenance and inspection every year or every two years.