

Progressive scan CCD color camera KP-FR39PCL/SCL Specifications (Preliminary)

1. General

The KP-FR39PCL/SCL are CameraLink output system progressive scan RAW data output color CCD camera with a 1/3-inch size CCD which adopted the RGB primary color filter and a full frame shutter.

The image of 659 (H) x 494 (V) is output in RAW data at 91 frames per second.

The square format picture elements provide suitability for image processing applications.

2. Outstanding features

(1) High speed and high color fidelity

The 1/3-inch 330,000 pixels square lattice progressive scan CCD and the RGB primary color mosaic filter achieve a high color fidelity of 659 (H) x 494 (V) (VGA) and high speed at 91 frames per second.

(2) Small-sized camera

The camera has small SDR connector for digital outputs.

Therefore, the camera has the realization of small-sized shape of 29 (W) x 29 (H) x 29 (D) mm.

(3) Remote control

- Multi-step electronic shutter (from 1/91 to 1/50000 second in 8 steps)

- Variable shutter (minimum 1/100000 second)

- Frame on demand (the image capture at desired timing using the external trigger signal) and other various functions are set by remote control via CameraLink cable.

(4) Power over CameraLink

Power supply of KP-FR39PCL is input via CameraLink cable.

(Note: Power supply of KP-FR39SCL is input from DCIN connector.)

-	Sep.14,2007	(first edition)	N.Abe	S.Hatanaka
SYMBOL	DATE	DESCRIPTION	(DRAWN)	DESIGNED

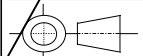
MODEL KP-FR39PCL/SCL		TOLERANCE	Prod. Code - Order No.	
DESIGNED	DATE	APPROVED	DATE	TITLE KP-FR39PCL/SCL Specifications
<i>A. Hatanaka</i>	Sep 14,07	<i>M. Suzuki</i>	Sep 14,07	
CHECKED	DATE	STORED	DATE	
<i>H. Nishikawa</i>	Sep 14,07	<i>H. Kushibiki</i>	Sep 18,07	REV. 0
Hitachi Kokusai Electric			DWG. No.	SHEET 1 / 16
			E400084815	

3. Specifications

A	(1) Imaging device	1/3-inch interline CCD	A
	Total pixels	692 (H) x 504 (V)	
	Effective pixels	659 (H) x 494 (V)	
	Pixel size	7.4 um (H) x 7.4 um (V) (square lattice)	
	Color filter	RGB primary color mosaic filter	
	(2) Sensing area	4.88 mm (H) x 3.66 mm (V)	
	(3) Scanning system	Progressive	
B	(4) Aspect ratio	4 : 3	B
	(5) Frame rate	91 frames per second (full pixel readout)	
	(6) Horizontal drive frequency	36.0000 MHz	
	(7) Horizontal scanning frequency	46.875 kHz	
	(8) Vertical scanning frequency	91.73 Hz	
	(9) Sync system	Internal	
	(10) Lens mount	C mount	
C	(11) Flange focal distance	17.526 mm	C
	(12) Video output	Digital output (CameraLink) Base configuration: 36.0000 MHz (Note: maximum cable length is 10 m) Output image: 659 (H) x 494 (V) (full pixel readout)	
	(13) Sensitivity	2000 lx, F4, 3200 K	
	(14) Minimum illumination	20 lx (F1.4, MAX GAIN)	
	(15) Signal noise to ratio	50 dB	
D	(16) Electric shutter	OFF, 1/91, 1/250, 1/500, 1/1000, 1/2000, 1/4000, 1/10000, 1/50000 second OFF is normal exposure (frame rate) or changeable by variable shutter (minimum 1/100000 second)	D
	(17) Gamma	$\gamma = 1$	
E	(18) Frame on demand	(A) Fixed shutter mode (8 steps or variable) (B) ONE trigger mode (C) Reset control mode (D) VD reset mode	E
	(19) Partial scan	Selectable start position and width of picture grabbing in 1H step.	
	(20) Power supply voltage	12 ± 1 VDC	
F	(21) Current consumption	Approx. 150 mA (approx. 1.8 W)	F

	1	2	3	4
A	(22) Ambient	Performance	0 to +40 °C (+32 to +104 F), less than 90 % RH	
		Operation	-10 to +50 °C (+14 to 122 F), less than 90 % RH	
		Storage	-20 to +60 °C (-4 to 140 F), less than 70 % RH (without dew condensation)	
B	(23) Vibration endurance		98 m/s ² (Acceleration: constant)	
			10 to 200 Hz, sweep: 10 minutes, XYZ 30 minutes	
	(24) Shock endurance	686 m/s ² (Drop test, once each top, bottom, left and right)		
	(25) External dimensions	29 (W) x 29 (W) x 29 (D) mm (Not including protrusions)		
	(26) Mass	Approx. 50 g		
C	(27) Remote control	(a) Signal system		
		Control system	Start-stop synchronization system	
		Transmission rate	9600 bps	
		Data length	8 bits	
		Start bit	1 bit	
		Stop bit	1 bit	
		Parity	None	
		Bit transfer	LSB first	
		(b) Communications control system		
			Full control by remote control software, data send/receive by text data transfer to camera Microprocessor (BSC system handshake).	
D	(c) Control items	1. Shutter speed	OFF, 1/91, 1/250, 1/500, 1/1000, 1/2000, 1/4000, 1/10000, 1/50000 second	
			Factory setting: OFF	
		2. Variable shutter	Minimum 1/100000 second	
		3. Mode	OFF, Fixed shutter, ONE trigger, Reset control mode and VD reset mode	
			Factory setting: OFF	
		4. Gain	0 to 18.5 dB (Approx. 0.04 dB step)	
			Factory setting: 0 dB	
		5. VD / FVAL	Factory setting: VD	
		6. HD / LVAL	Factory setting: HD	
		7. 8bit / 10bit	Factory setting: 10bit	
E		8. HD reset / NON reset	Factory setting: HD reset	
		9. Partial scan	Factory setting: OFF	
		10. Trigger pulse polarity	Factory setting: POS	
F				

4. Composition

- (1) Camera (with IR cut filter)
 (2) Operation manual

5. Optional accessories

- (1) Dummy glass (AR coated) ARC1214
 (2) IR cut filter IRC650
 (3) Junction box (for KP-FR39SCL) JU-M1A, JU-F1
 (4) Tripod adaptor TA-F200S
 (5) 12pin plug (for KP-FR39SCL) HR10A-10P-12S(01)
 (6) Camera cable (for KP-FR39SCL)

	Molded type	Shield type
2 m	C-201KSM	C-201KSS
5 m	C-501KSM	C-501KSS
10 m	C-102KSM	C-102KSS

In the CE Marking region, use the shield type.

(7) Digital out cable

- Mini CameraLink cable (for KP-FR39SCL) SDR-MDR type

Cable length	Model name
1m	C-101SCL
2m	C-201SCL
3m	C-301SCL
5m	C-501SCL
10m	C-102SCL

- PoCL cable (for KP-FR39PCL)

Cable length	Model name	
	SDR-SDR type	SDR-MDR type
1m	C-101PCL (SS)	C-101PCL (SM)
2m	C-201PCL (SS)	C-201PCL (SM)
3m	C-301PCL (SS)	C-301PCL (SM)
5m	C-501PCL (SS)	C-501PCL (SM)
10m	C-102PCL (SS)	C-102PCL (SM)

SDR: Shrunken Delta Ribbon

MDR: Miniature Delta Ribbon

6. Signal connection to connector

Pin No.	Signal	Pin No.	Signal
1	+12V (KP-FR39PCL)	14	GND
	GND (KP-FR39SCL)		
2	TXOUT 0 (-)	15	TXOUT 0 (+)
3	TXOUT 1 (-)	16	TXOUT 1 (+)
4	TXOUT 2 (-)	17	TXOUT 2 (+)
5	TXCLKOUT (-)	18	TXCLKOUT (+)
6	TXOUT 3 (-)	19	TXOUT 3 (+)
7	RX (+) [SERTC (+)]	20	RX (-) [SERTC (-)]
8	TX (-) [SERTFG (-)]	21	TX (+) [SERTFG (+)]
9	TRIG-A/VD (-) [CC1 (-)]	22	TRIG-A/VD (+) [CC1 (+)]
10	TRIG-B (+) [CC2 (+)]	23	TRIG-B (-) [CC2 (-)]
11	N.U. [CC3 (-)]	24	N.U. [CC3 (+)]
12	N.U. [CC4 (+)]	25	N.U. [CC4 (-)]
13	GND	26	+12V (KP-FR39PCL)
			GND (KP-FR39SCL)

Connector (camera side) SDR connector (Sumitomo 3M) or equivalent

N.U.: Not used

- The digital out cable should be comprised of a twisted pair of wires having 100 ohm characteristic impedance and an outer sheath shield type conductor.
- Connect the shield (ground) of the digital out cable to the ground terminal of the video equipment, frame grabber, etc.
- Install clamp filter (ZCAT2035-0930A: TDK) at both ends (camera and video processor ends) in the CE marking region.
- TX: Transmit data from camera to machine
- RX: Transmit data from machine to camera

(Note) Please do not unplug and insert cable (digital out cable) with a power supplied to a camera.

(Note) Power of KP-FR39SCL is input from DCIN connector.

Pin No.2, 11: +12V

Pin No.1, 10: GND

Pin No.3, 4, 5, 6, 7, 8, 9, 12: Not used

7. CameraLink output

A

A

7-1. Horizontal timing

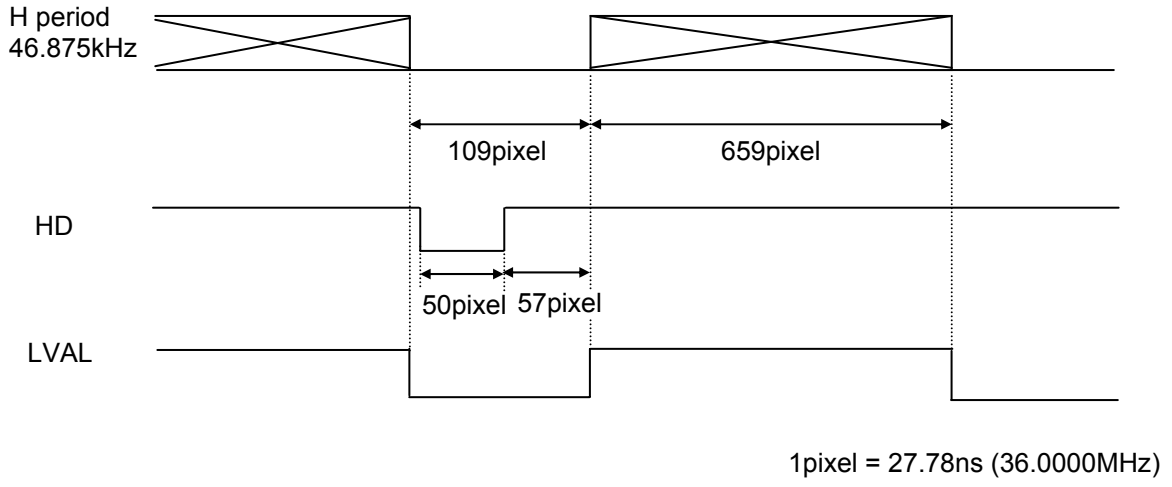

B

B

C

C

7-2. Vertical timing

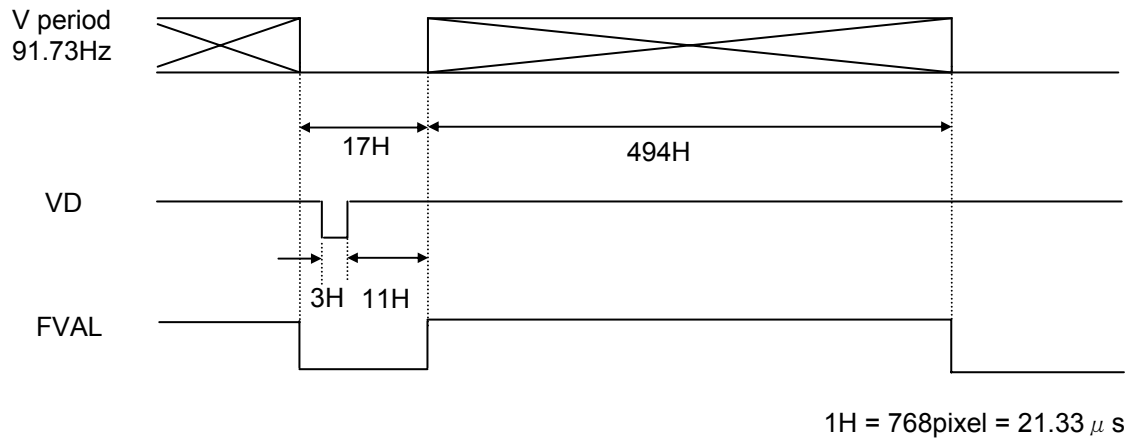

D

D

E

E

F

F

7-3. Transmitter LVDS output pulse position measurement

A

(1) 10bit

A

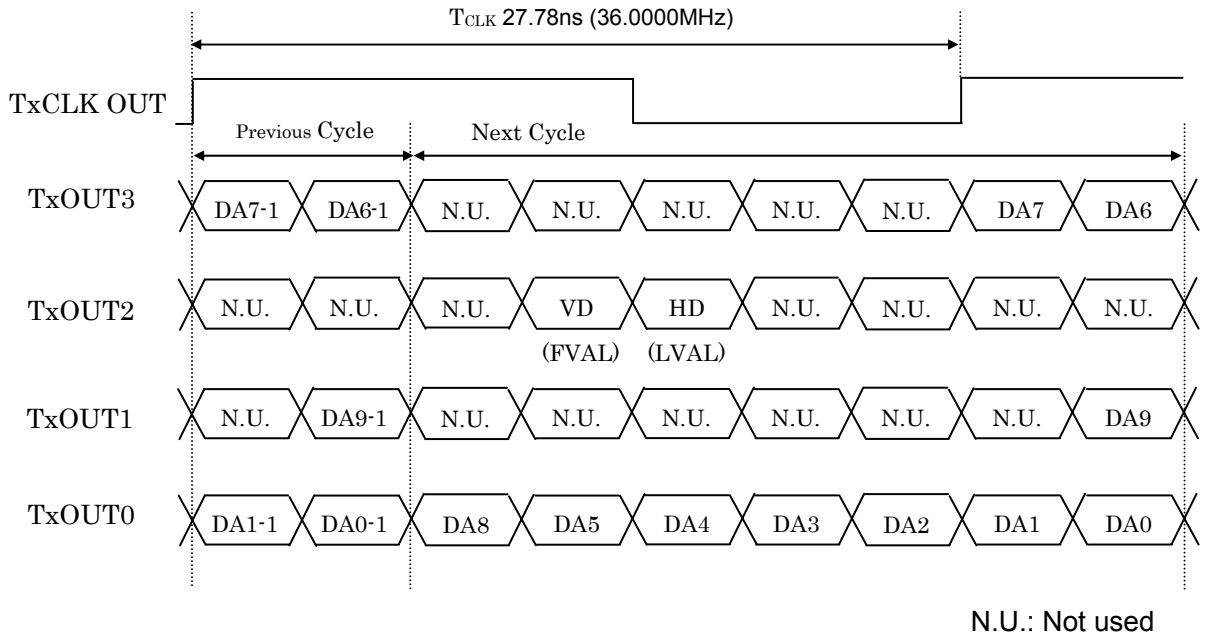

B

B

C

C

(2) 8bit

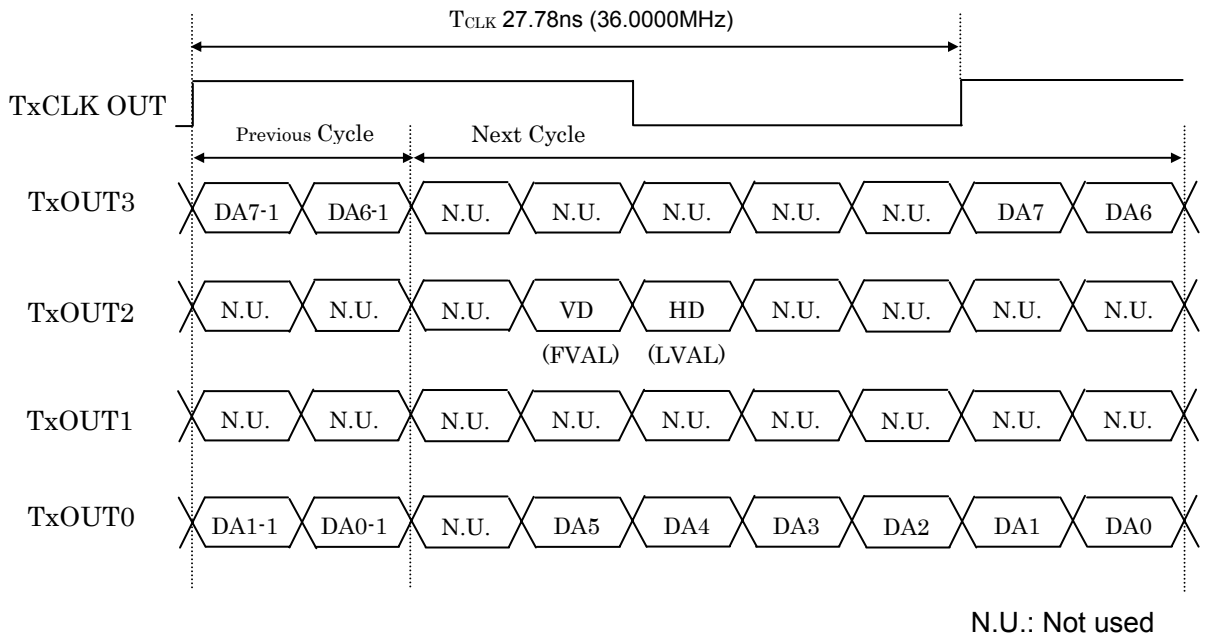

D

D

E

E

F

F

1 2 3 4

8. Timing chart

8-1. Normal mode

1H = 46.875KHz = 21.33us

When partial scan is ON, *1 to *4 are variable by start position of picture grabbing and width of picture grabbing (omit the figures after the decimal fractions).

- *1: $(17 + \text{Width} + (496 - \text{Width}) / 7)H$
- *2: $(3 + (496 - \text{Width}) / 7 - \text{Start} / 7)H$
- *3: $(11 + \text{Start} / 7)H$
- *4: $(\text{Width})H$

Note1: Please use the partial scan in following condition.
 $\text{Start} + \text{Width} \leq 495$

Note2: Please use FVAL in the partial scan.

Graph following shows frame rate in each width of picture grabbing when partial scan is ON.

Width of picture grabbing [H]	Frame rate [fps]
0	530
100	300
200	180
300	130
400	110
500	100

Note: Frame rate can be calculated from following equations using width of picture grabbing.

Lines = $17 + \text{Width} + (496 - \text{Width}) / 7$

Frame rate = $(36000000 / 768) / \text{Lines}$

DWG. No. **E400084815** SHEET 8 / 16

1 2 3 4 DF022-4PE-SI 4

8-2. Fixed shutter mode

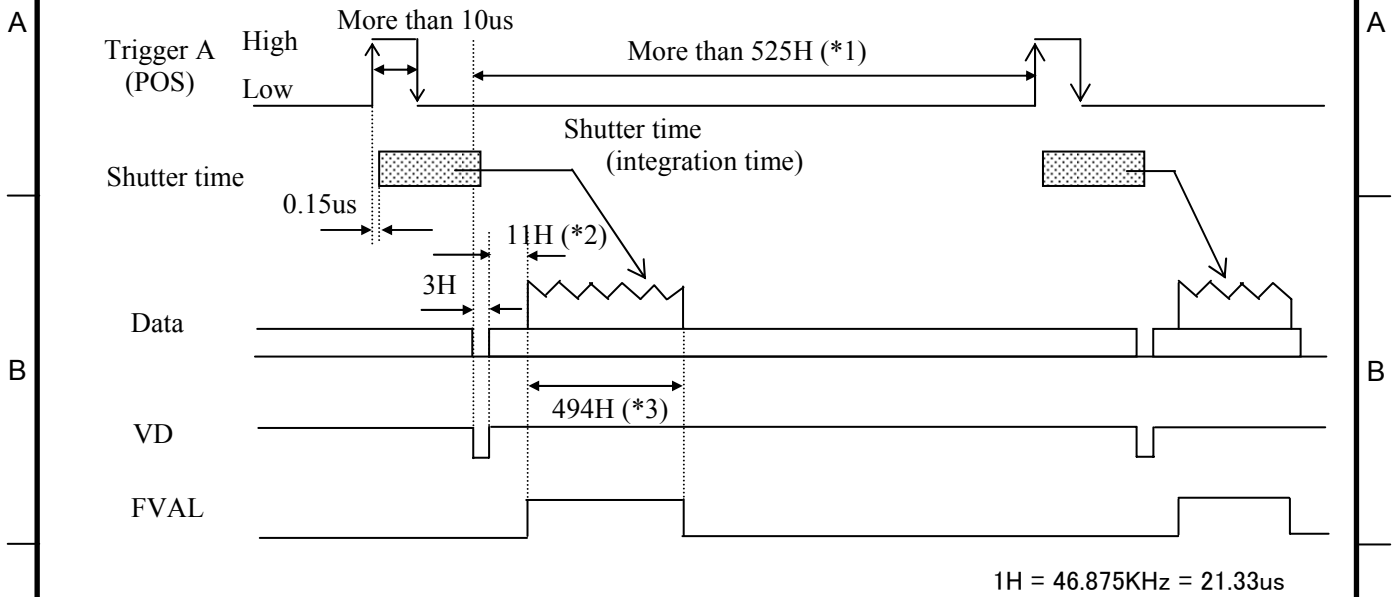

When partial scan is ON, *1 to *3 are variable by start position of picture grabbing and width of picture grabbing (omit the figures after the decimal fractions).

- *1: $(17 + Width + (496 - Width) / 7)H$ or more
- *2: $(11 + Start / 7)H$
- *3: $(Width)H$

Note1: Please use the partial scan in following condition.

$$Start + Width \leq 495$$

Note2: Please use FVAL in the partial scan.

8-3. ONE trigger mode

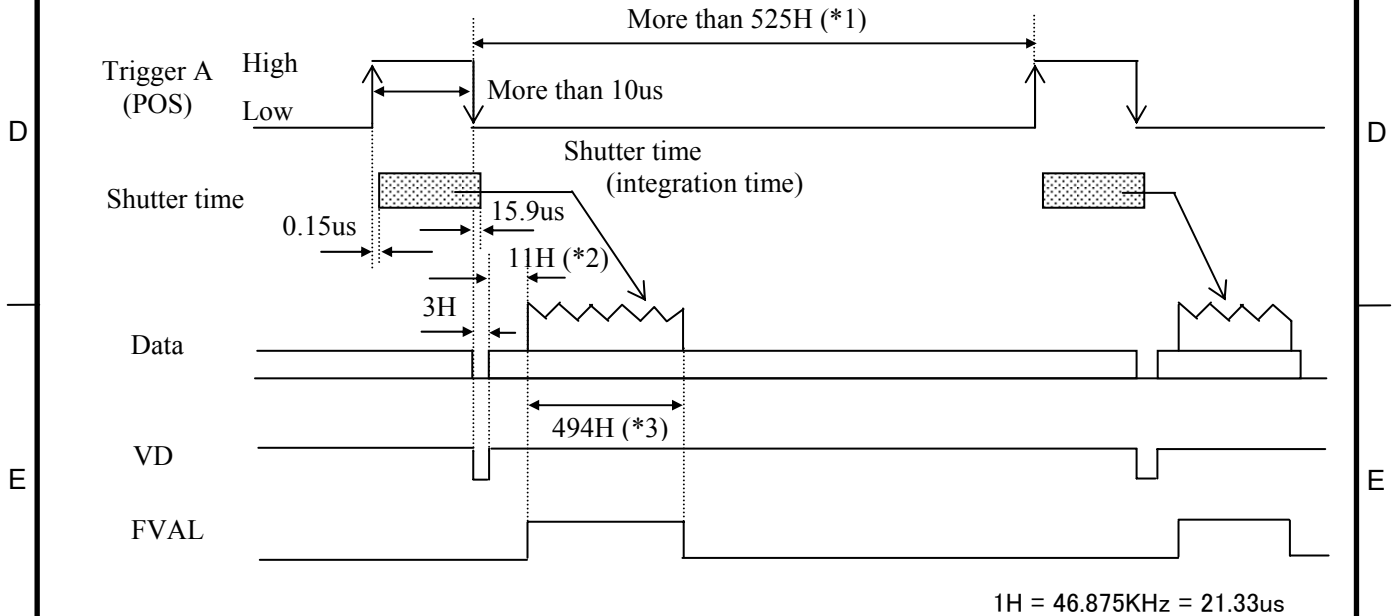

When partial scan is ON, *1 to *3 are variable by start position of picture grabbing and width of picture grabbing (omit the figures after the decimal fractions).

- *1: $(17 + Width + (496 - Width) / 7)H$ or more
- *2: $(11 + Start / 7)H$
- *3: $(Width)H$

Note1: Please use the partial scan in following condition.

$$Start + Width \leq 495$$

Note2: Please use FVAL in the partial scan.

8-4. Reset control mode

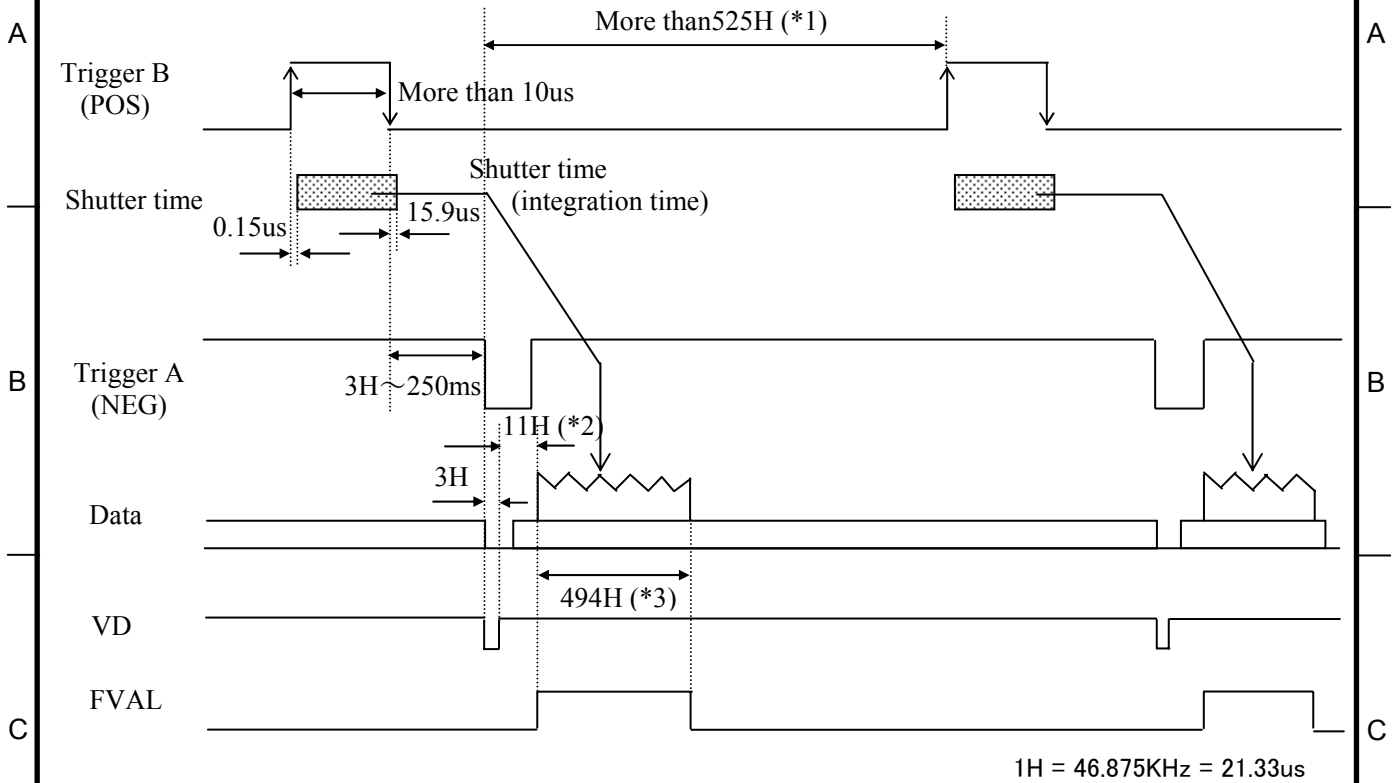

When partial scan is ON, *1 to *3 are variable by start position of picture grabbing and width of picture grabbing (omit the figures after the decimal fractions).

*1: $(17 + \text{Width} + (496 - \text{Width}) / 7)H$ or more

*2: $(11 + \text{Start} / 7)H$

*3: $(\text{Width})H$

Note1: Please use the partial scan in following condition.

$\text{Start} + \text{Width} \leq 495$

Note2: Please use FVAL in the partial scan.

Special function of reset control mode

The camera shifts to the output of a normal mode (continuous output) when Trigger B signal passes about 1/3 second in the state of High.

It returns to the Trigger mode if Trigger B signal becomes Low.

However, after becoming Low Trigger B, the period of 50 ms becomes a Trigger signal input prohibition period.

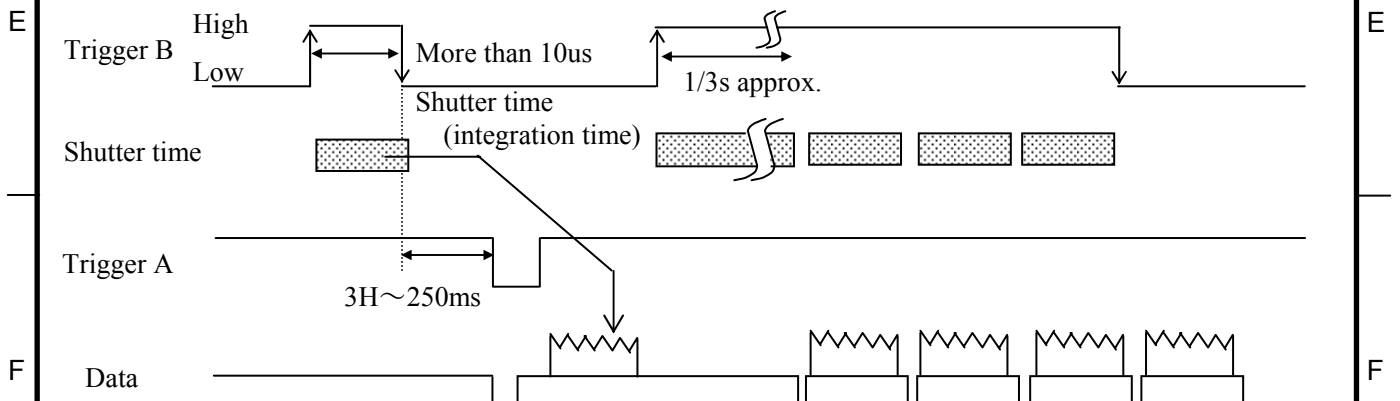

DWG. No. **E400084815**

SHEET
10 / 16

8-5. VD reset mode

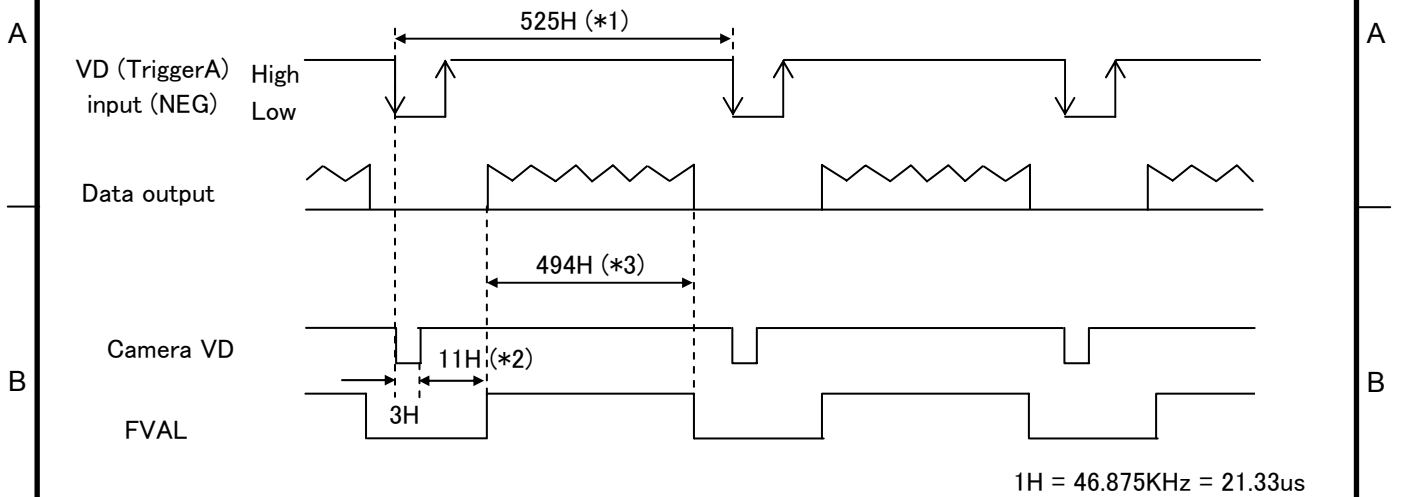

When partial scan is ON, *1 to *3 are variable by start position of picture grabbing and width of picture grabbing (omit the figures after the decimal fractions).

*1: $(17 + \text{Width} + (496 - \text{Width}) / 7)H$

*2: $(11 + \text{Start} / 7)H$

*3: $(\text{Width})H$

Note1: Please use the partial scan in following condition.

$\text{Start} + \text{Width} \leq 495$

Note2: Please use FVAL in the partial scan.

NOTE: If the external VD of cycle which does not match the camera operation mode is input, shutter time has an error.

9. Output sequence

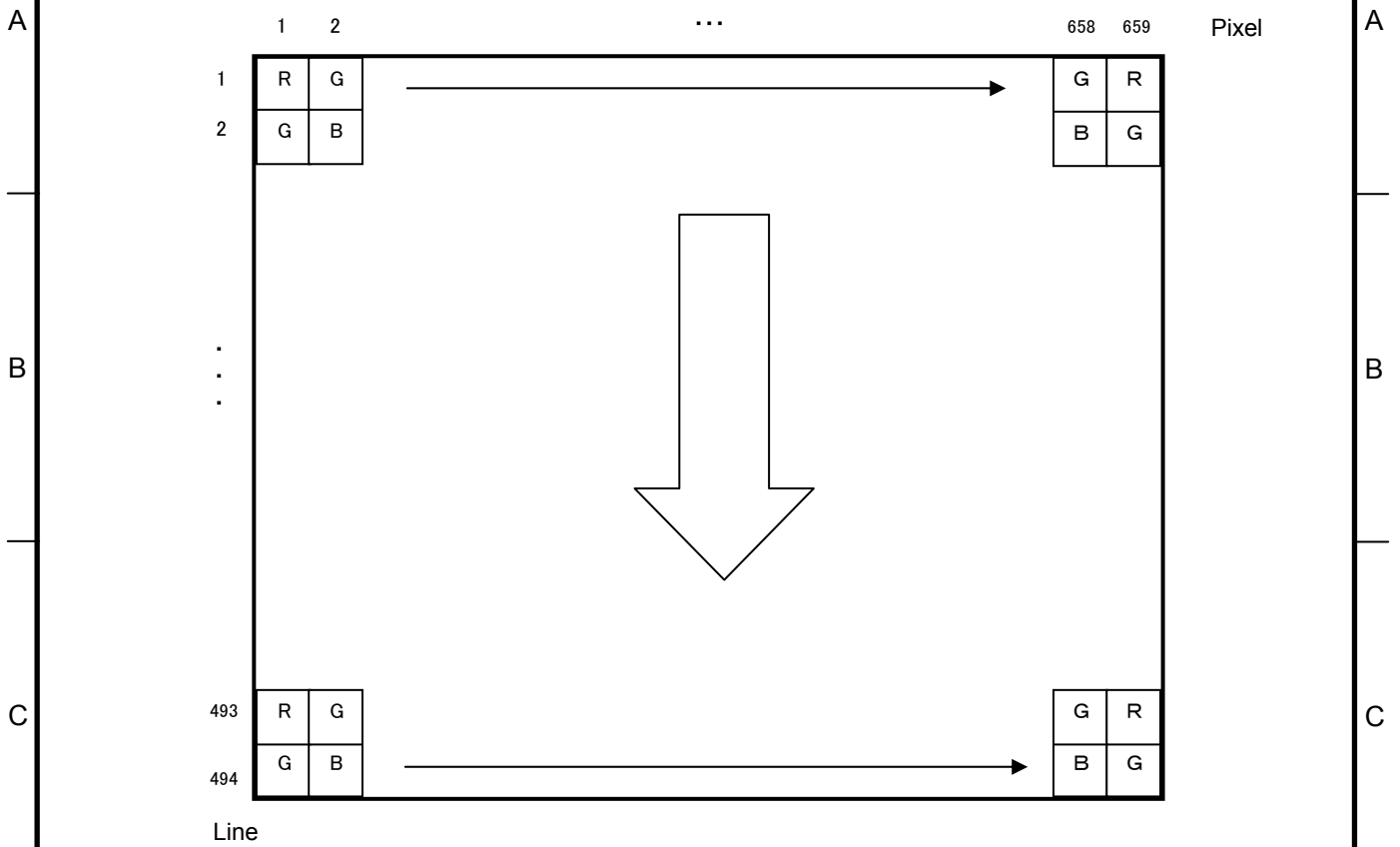

10. Spectral response

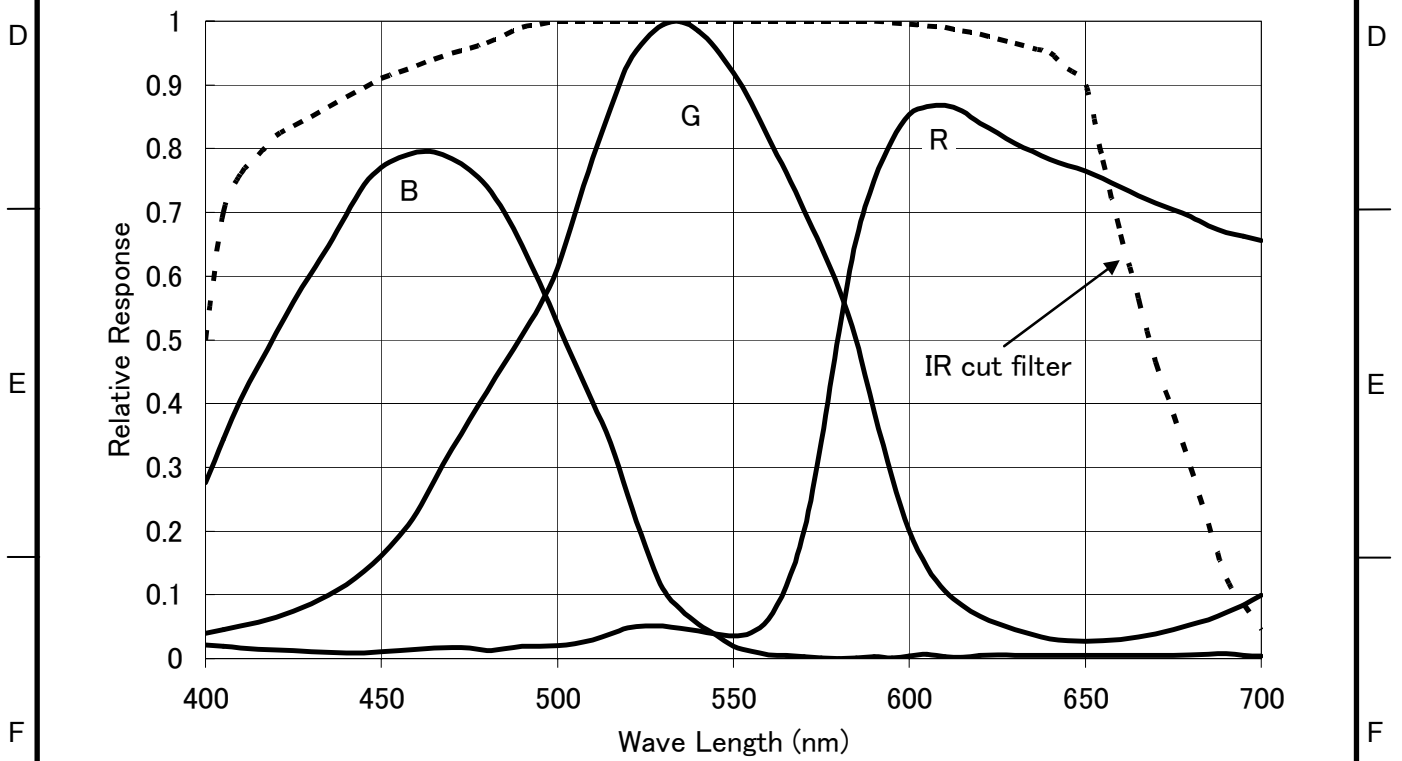

11. External view

11-1. KP-FR39PCL

- MASS : APPROX 50 g
- COLOR : BLACK
- TOLERANCE : ± 0.5
- UNIT : mm

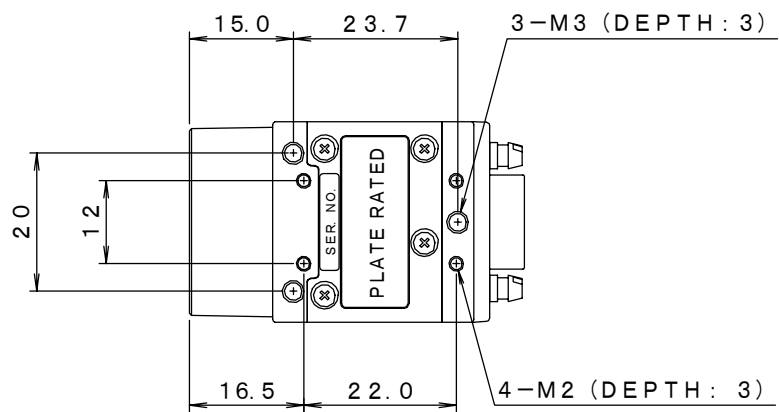
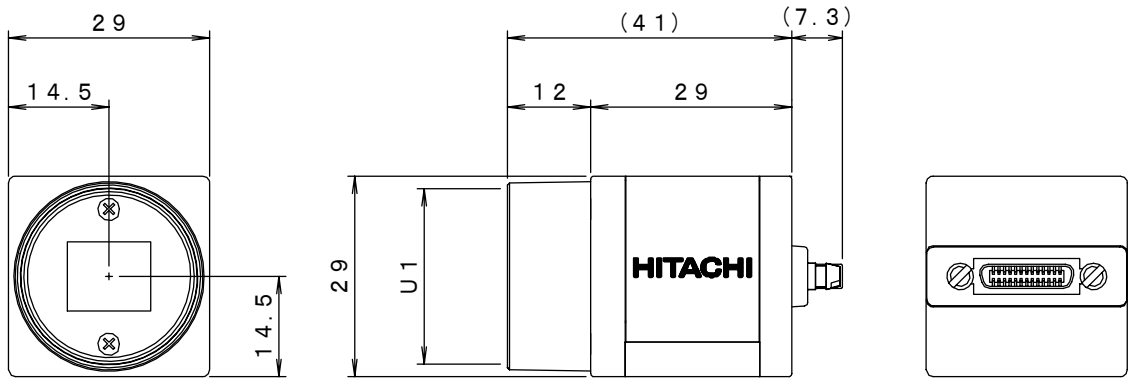
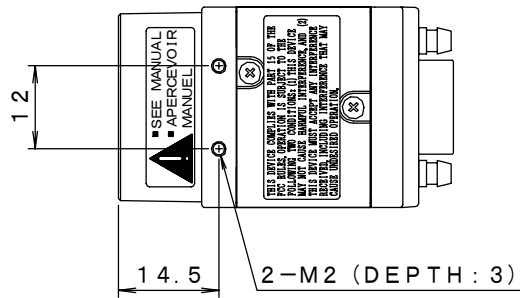

11-2. KP-FR39SCL

- MASS : APPROX 50 g
- COLOR : BLACK
- TOLERANCE : ± 0.5
- UNIT : mm

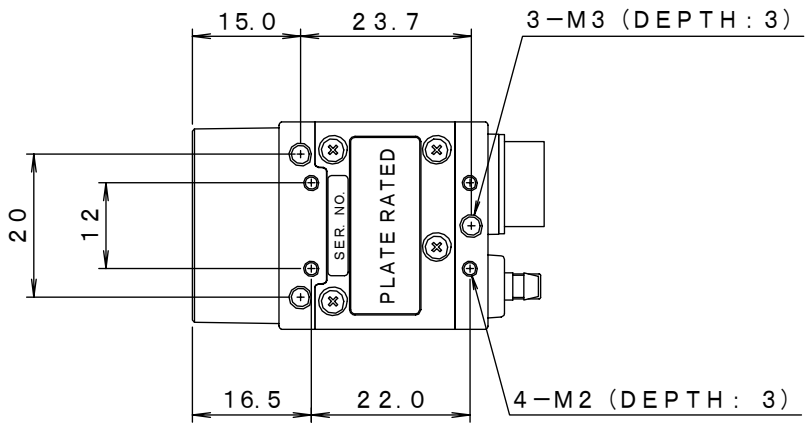
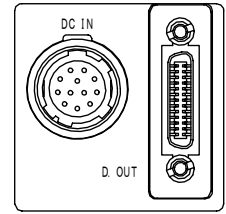
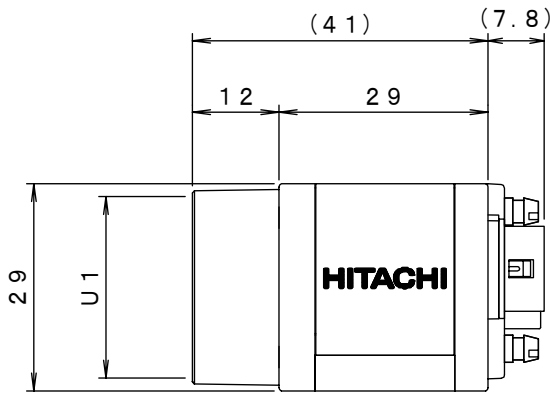
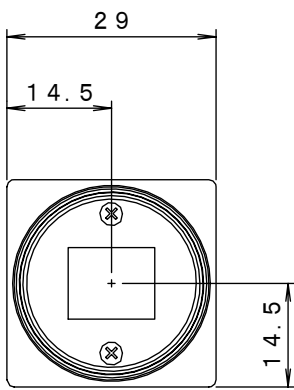
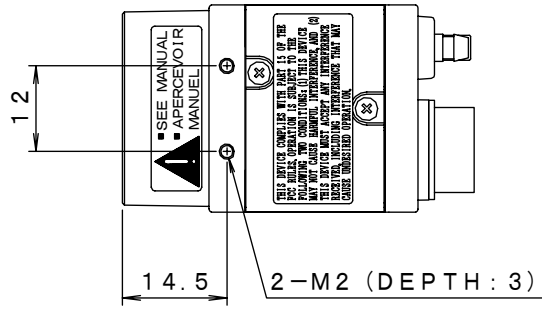

Notice:

These specifications are subject to change without prior notice due to product improvement.

Confirm the most recent specifications at time of order.

Hitachi Kokusai certifies this product complies with the standard warranty conditions of Hitachi Kokusai, and that quality control is implemented to the extent required to comply with these conditions.

RoHS Compliant

This product complies with the requirement of the RoHS(Restriction of the use of Certain Hazardous Substances in Electrical and Electronic Equipment) Directive 2002/95/EC

Warranty and service:

- (1) The guarantee period is one year after the data purchase.
However, the defects due to erroneous use or intentional act are excluded.
- (2) As the defect after expiration of the guarantee period, where product repair is possible, repair will be performed at charge.
- (3) The present Warranty pertains only to the camera unit. Secondary malfunctions attributable to camera failure as well as expenses incurred by disassembly and reassembly of the related system, are beyond the scope of this Warranty.
- (4) Compensation for loss of business, loss or damage to software, database and other contingent losses are beyond the scope of this Warranty.
- (5) Hitachi Kokusai Electric Inc. is not liable for the losses caused when the equipment is used in a system, use for business trades, production process, medical fields, crime prevention applications, etc.
- (6) In the case of camera trouble by miss wiring of cable, it will be considered as out of warranty.

