



# EAGLE

PAN TILT SYSTEMS

Helping to bring your world  
into focus

## PT-50 / PT-C50

### Operations and Instructions Manual

#### Revision 2.1

#### 10/30/02



Designed and Manufactured by

Eagle Pan Tilt Systems

5880 N. Sheridan Blvd.

Arvada, CO 80003

(303)412-0399

[www.eaglepan tilt.com](http://www.eaglepan tilt.com)

# Contents

IMPORTANT SAFETY INSTRUCTIONS .....	3
ITEMS INCLUDED WITH YOUR NEW PT-50 PAN TILT HEAD: .....	5
UNPACKING AND INSTALLING THE PT-50 PAN TILT HEAD .....	5
SETTING THE ADDRESS OF THE PT-50 PAN TILT HEAD .....	8
RS-485 CONNECTION AND TERMINATION .....	9
RS-232 SERIAL OPERATION .....	10
ENERGIZING THE SYSTEM .....	10
USING THE PT-50 PAN TILT WITH PT-C-50 CONTROL PANEL .....	10
FUNCTION DEFINITIONS FOR PT-C-50 CONTROL PANEL .....	11
CAMERA NUMBER .....	11
SAVE FUNCTION .....	11
A.IRIS .....	12
FUNCTION .....	12
POS .....	12
LIMIT .....	12
CHAIN .....	12
AUTO WHITE .....	13
SPEED .....	13
SHIFT .....	13
FUNCTION MODES .....	13
PRESET 1– PRESET SPEED CHANGE .....	13
PRESET 2– SCENE FILE ASSIGNMENT .....	13
PRESET 3–INVERT DIRECTION .....	14
PRESET 4–ADDRESS OF PAN TILT HEAD .....	14
PRESET 5–SET LENS TYPE. ....	14
PRESET 6–HEAD STATUS CHECK .....	14
CAMERA FUNCTIONS .....	15
PAN-TILT OPERATIONS .....	15
EAGLE™ PT-PS Series Pan Tilt Head–Power Supplies Installation and Operations Manual .....	16
PRECAUTIONARY STATEMENT .....	16
WARRANTY .....	16
HARDWARE INSTALLATION .....	16
POWER REQUIREMENTS AND PIN CONFIGURATIONS .....	16
FREQUENTLY ASKED QUESTIONS / SETUP PROBLEMS .....	18

# PRECAUTIONARY STATEMENT AND WARRANTY

Please read all of the following documentation before attempting the installation and configuration of these systems. If any of the instructions are unclear to you, call your servicing dealer or Hitachi before proceeding for clarification. Failure to correctly configure and install these systems may cause damage to the equipment, and will void the warranties. Please make sure before connecting or disconnecting any cables that the power supplies are turned OFF.

## WARRANTY

Hitachi Denshi America, Ltd. warrants to the original customer that each PT-50 unit shall be free from malfunction due to defective workmanship or component failure for a period of TWO YEARS from the original date of delivery to the customer. For service under the warranty period, return authorization **must** be obtained before returning the product. This warranty does not apply to finish or appearance items, to malfunction due to abuse, or operation in violation of published operating specifications, or to failures caused by improper installation, connections, modifications, alterations, or other unauthorized repairs. This warranty does not cover labor or shipping costs for removal and/or reinstallation of equipment under warranty. Under no circumstances shall Hitachi Denshi America, Ltd. or Display Devices, Inc., their owners or employees be liable to you for any special damages, including any lost profits, lost savings, or other incidental or consequential damages, or for any claim by any other party.

### IMPORTANT SAFETY INSTRUCTIONS



1. Read ALL The Instructions! All the safety and operating instructions should be read before the product is operated
2. Retain Instructions. These safety and operating instructions should be retained for future reference.
3. Heed Warnings. All warnings on the product and the operating instructions should be adhered to.
4. Follow Instructions. All operating and use instructions should be followed.
5. Cleaning. Unplug this product from the power supply before cleaning. Do not use liquid cleaners or aerosol cleaners. Use only a damp cloth for cleaning.
6. Attachments. Do not use attachments not recommended by the product manufacturer as they may cause hazards.
7. Water and Moisture. Do not use this product near water--for example, near a bath tub, wash bowl, kitchen sink, or laundry tub, wet basement, swimming pool, pond, or similar areas.
8. Accessories. Do not place this product on an unstable cart, stand, tripod, bracket, or table. The product may fall, causing serious

injury to a child or adult, and cause serious damage to the product. Use only with a cart, stand, tripod, bracket, or table recommended by the manufacturer, or sold with the product. Any mounting of the product should follow the manufacturers' instructions, and should use only mounting accessories recommended by the manufacturer.

9. Moving. A product and cart combination should be moved with care. Quick stops, excessive force, and uneven surfaces may cause the product and cart combination to overturn.

10. Ventilation. The outer case of the unit functions as a heat sink for the electronics contained inside. Do not block off the product from airflow by placing the product on a bed, sofa, rug, or similar surface. This product should not be placed in a built-in installation such as a bookcase or rack unless proper ventilation is provided or the manufacturers' instructions have been adhered to .

11. Power Sources. This product should be operated only from the type of power source indicated on the marking label. If you are not sure of the type of power supply to your facility, consult your product dealer or local power company.

12. Grounding or Polarization. This product's power supply is supplied with a three wire grounding type plug; a plug having a third (grounding) pin. This is a safety feature. If you are unable to insert the plug into the outlet, contact an electrician to replace the obsolete outlet. Do not defeat the purpose of the grounding plug.

13. Power cord protection. Power supply cords should be routed such that they are not likely to be walked on or pinched by items placed upon or against them, paying particular attention to the cords at plug, receptacle, and to the point at which they enter the power supply and the product.

14. Lightning. For added protection for this product during a lightning storm, or when it is left unattended and unused for long periods of time, unplug it from the wall outlet. This will prevent damage to the product due to lightning and power line surges.

15. Overloading. Do not overload wall outlets, extension cords, or receptacles as this can result in a risk of fire or electric shock.

16. Object and liquid entry. Never push objects of any kind into this product through openings as they may touch voltage points or short out parts that could result in a fire or electrical shock. Never spill liquid of any kind on the product.

17. Flammable and Explosive substances. Avoid using this product where there are gases and also where there are flammable and explosive substances in the immediate vicinity.

18. Heavy shock or vibration. When carrying this product around, do not subject the product to heavy shock or vibration.

19. Servicing. Do not attempt to service this product yourself as opening or removing covers may expose you to dangerous voltage or other hazards. Refer all servicing to qualified service personnel.

20. Damage requiring service. Unplug this product from the wall outlet and refer servicing to qualified service personnel under the following conditions: a--When the power supply cord or plug is damaged. b--if liquid has been spilled, or objects have fallen into the product. c--If the product has been exposed to rain or water. d-- if the product does not operate normally by following the operating

instructions. Adjust only those controls which are covered by the operating instructions as improper adjustment of other controls may result in damage and will often require extensive work by a qualified technician to restore the product to its normal operating range. e-- if the product has been dropped or damaged in any way. f--When the product exhibits a distinct change in performance, this indicates a need for service.

21. Replacement parts. When replacement parts are required, be sure that the service technician has used replacement parts specified by the manufacturer or have the same characteristics as the original part. Unauthorized substitutions may result in fire, electric shock, or other hazards.

22. Safety Check. Upon completion of any service or repairs to this product, ask the service technician to perform safety checks to determine that the product is in proper operating condition.

23. Wall or Ceiling mounting. This product should only be mounted to a wall or ceiling using brackets made and/or as specified by the manufacturer.

24. Heat. The product must be situated away from heat sources such as radiators, heat registers, stoves, or other products (including amplifiers or direct sunlight) that produce heat.

---

#### **ITEMS INCLUDED WITH YOUR NEW PT-50 PAN TILT HEAD:**

PT-50 PAN TILT HEAD

ADJUSTABLE CAMERA BRACKET

CAMERA MOUNTING SCREW

5 PIN POWER/DATA INPUT CONNECTOR PACK

CAMERA POWER AND CONTROL CABLE

OPTIONAL: 15 PIN LOOP THRU CABLE FOR COMPONENT-Y/C CONNECTION

---

#### **UNPACKING AND INSTALLING THE PT-50 PAN TILT HEAD**

Included with this package is a graphical flow chart showing images of the correct manner of installation. Use it in conjunction with these written instructions to complete the installation of the PT-50 system.

Remove the PT-50 head, camera bracket and accessories from the protective foam packaging. It is recommended to save this packaging until the installation is complete and the head has been put into operation, in the unlikely event that there is a problem

and it needs to be returned for service.

Choose either the wall/table mounting configuration, or optional ceiling mount configuration. If utilizing the optional PT-WM-S wall mount, make sure that the wall can support a weight of at least 30 lbs. (or 2.5 times the max. weight of the PT-50 head, camera, lens, and bracket)

If using the optional PT-CM-50 ceiling mount adapter, install the adapter on the base of the head now using the accessory kit supplied with the adapter. Make certain that the ceiling structure can support a weight of at least 30 lbs. (or 2.5 times the max. weight of the PT-50 head, camera, lens, and bracket).

Depending upon the lens and camera combination, follow the recommendation chart included to select the proper camera / lens bracket assembly. Using the bracket pieces, assemble the bracket and attach it to the camera. Attach the angle mount bracket to the tilt mounting disc on the side of the head. Keep in mind that if you are ceiling mounting (inverting) the head, the angle bracket must be inverted as well. (see photo)

Take the camera / lens / bracket assembly, place it on a desktop or other flat surface, with a pen or pencil underneath the bracket. Carefully roll the assembly forward and back until the balance point is found. Using the photos as a guide, attach the camera/lens bracket to the angle bracket using the special bolt and knurled lock down knob. Center the balance point you found previously in the center of the angle bracket.



**NOTE:** It is very important to make certain the center points are coincident. If they are not, the front / rear balance will be off, and the pan tilt head may suffer performance degradation to the point of not working. Please make sure to check the front/rear balance before calling for service.

When centered, tighten the knurled lockdown knob to secure the assembly.

Attach the pre-built supplied cable harness from the rear of the pan tilt to the rear of the camera. Note that the proper connectors are supplied for your particular camera model for power and control ports. Attach the lens control cable from your lens to the connector on the rear of the pan tilt head. If you are using a C mount lens with auto iris, and your camera supports auto iris operation, attach the four pin link from your camera body to the four pin connector on the lens body.

If using the optional 15 pin pass thru cable for component, RGB, or Y/C signal output, attach it between the camera body and the 15 pin socket on the rear of the PT-50 head. You must supply your own breakout cable to attach to the 15 pin connector on the base of the pan tilt head, or buy a specially made one direct from Hitachi. Several configurations of cable are available depending upon your needs. If making your own cable, the pin outs are shown in an attached diagram.

Here is a table showing the types of cameras and lens configurations supported by the PT-50 :

CAMERA MODEL	LENS MODEL	SET LENS TYPE ON EAGLE CONTROLLER TO:	AUTO IRIS/REMOTE IRIS
HV-C20/HV-D30/HV-D25	CANON PH10X8.5 RGE PZF, PH15X 8 RGE PZF	TYPE 1	AUTO IRIS ONLY
HV-C20/HV-D30/HV-D25	FUJINON C MOUNT LENSES ENDING WITH -S41	TYPE 1	AUTO IRIS ONLY, NO LENS PRESET POSITIONS
HV-C20/HV-D30/HV-D25	FUJINON C MOUNT LENSES ENDING WITH -Y41	TYPE 1	AUTO IRIS ONLY, WITH PRESET POSITIONS
HV-C20/HV-D30/HV-D25	FUJINON C MOUNT LENSES ENDING WITH -R11	TYPE 2	AUTO OR REMOTE IRIS, WITH PRESET POSITIONS
HV-D15/16	FUJINON OR CANON TELECONFERENCING LENSES	TYPE 2	AUTO OR REMOTE IRIS, WITH PRESET POSITIONS



NOTE: All cameras used with the PT-50 head must be set to RS-232 communications if remote camera control is desired via the optional PT-CCB-50 chipset!! Consult the Hitachi camera operation manual for details on how to do this.

If your camera / lens combination does not appear in this table, contact Eagle™ tech support for configuration help.

Next, build up and attach the 5 pin main power and data connector to the bottom of the PT-50 head.



NOTE: It is very important to build and install this cable correctly; if the data and power conductors are flipped or misoriented, severe damage may be caused to the pan tilt head, rendering it inoperable. It is easy for our technicians to tell when miswiring has taken place due to the damage it causes. This type of miswiring is **NOT** covered by the warranty.

Here is a table showing the correct wiring order and purpose. Please note that the connector on the base of the head is labeled with numbers from 1 to 5:

5 pin connector on base of PT head	MAIN PAN TILT CONTROL INTERFACE
PIN 1	RS-485 GROUND
PIN 2	RS-485 LINE 1
PIN 3	RS-485 LINE 2
PIN 4	+24VDC FROM MAIN POWER SUPPLY PIN 1 OR 2
PIN 5	GROUND TO 24VDC MAIN POWER SUPPLY PIN 3 OR 4

Now you may hook up the wiring to the Eagle™ control system and power supply, using the instructions included with those devices. If you are using the Eagle™ PT-T2 connection block, follow the instructions included with the PT-T2 for system configuration choices. Proceed to the next step ONLY when the system wiring is complete, and all connections have been verified for accuracy.

### SETTING THE ADDRESS OF THE PT-50 PAN TILT HEAD

All Eagle™ PT-50 pan tilt heads require a separate address for controlling them by serial communication. Each pan tilt on the RS-485 line has a specific logical address. This address may be set by software control from one of the Eagle™ controllers or software packages, or set mechanically via the dip switches located under the removable side access panel on the PT-50 head. To access the address setting switches, remove the two small Philips type screws securing the cover. With the cover removed, you will see a bank of four white switches. The convention for the switches is this: down is OFF (or zero), up is ON. With all switches down/off, the head's address is set by remote control.

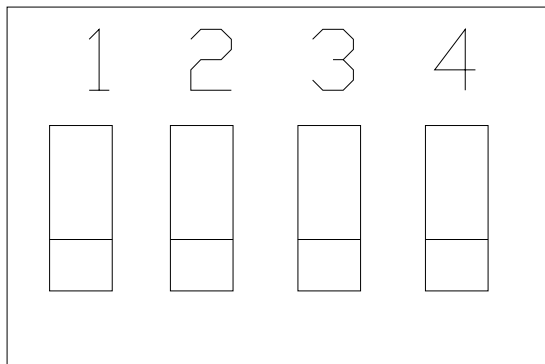

Representation of DIP switch module for setting PT-50 head address

With only switch number 1 in the up position, the head's address is 1. With only switch number 2 up, the address is 2. With only switch number 3 up, the address is 4. With only switch number 4 up, the address is 8. The switches may be configured in any manner to arrive at a desired address up to 15 (all switches up=1+2+4+8=15). For example, to set address number 3, switches 1 and 2 should be up. For address 6, switches 2 and 3 should be up (2+4=6). For numbers higher than 15, leave all the switches OFF and set the address via the Eagle™ control panel or software.

To set the address by remote control or software, follow this procedure. The address is set by the factory to 1 when shipped. If a change is required, follow the procedure for your particular model of Eagle™ controller:

PT-C-50 controller: Enter FUNCT, PRESET 4, then select PRESET 1 through 8 to set addresses from 1 through 8. Note that the PT-C-50 controller is limited to control of 8 PT heads.

PT-C controller: simply enter FUNCTION, the 11 button; the LCD display will read ADDRESS. Then push the number you wish to set the head to.

PT-TSC touchscreen controller: From the main page, touch the FUNCTION button. Then touch the SET PT ADDRESS button. On the numeric keypad that pops up, touch the number you wish the head to become, followed by the ENTER button.

Note that the addressing procedure will only work if you know the number the head is currently set to; if you don't know the number, first select CAMERA, ALL. This will allow you to talk to any head that is correctly wired up and powered.



Note that this will set the number for all heads on the RS-485 comm line; you must disconnect the power or communication for all the heads except the one you wish to address, otherwise all the powered and connected heads will be set to the same address.

## RS-485 CONNECTION AND TERMINATION

Communications for the PT-50 is transmitted via the RS-485 standard, a common multidrop network configuration. Three wires are required for RS-485 communications, two for signal and one for ground. Using 20 AWG shielded twisted pair cable, maximum communication length without a repeater is 4,000 feet.

To connect multiple units to the same communication line, connect the three wires in parallel from unit to unit. On each of the pan tilt heads and in the controller is a 120 ohm terminating resistor. The resistor is connected in series to a switch for easy configuration; this switch for termination is located on the side of the unit (under the removeable access panel) next to a COMM status LED; with the switch towards the LED, the head is terminated; with the switch away from the LED, the head is unterminated. Heads are shipped with the termination turned ON. The easiest way to terminate your system is to terminate the head that is farthest away by cable distance, and leave the controller terminated. Any other head should NOT be terminated.

If using a controller other than the Eagle™ pan tilt controller, such as an AMX or Crestron control system, termination should be provided at the card cage end.

## **RS-232 SERIAL OPERATION**

The PT-50 pan tilt head is capable of direct RS-232 operation right out of the box. No adapters are needed. Under the side cover access panel you will find three black repositionable jumpers. The PT-50 is shipped in standard RS-485 mode; with all of the jumpers UP.

Switch all three of the jumpers to the lower position, and the head is now configured for RS-232 mode. The same control codes used for RS-485 apply for moving the head using Eagle™ software or when writing your own software. These control codes are available off of the Eagle website, <http://www.eaglepantilt.com>. Please be aware that the maximum reliable distance for RS-232 control is only about 50 to 75 feet, and that only one PT-50 head may be hooked up per serial port as is standard with RS-232 communications.

## **ENERGIZING THE SYSTEM**

Power up the Eagle™ pan tilt controller before powering up the PT-50 pan tilt head. When this is done, you may now power up the power supply for the PT-50 head(s). Observe the red status LED lens on the side of the pan tilt head. About two seconds after power is applied, the LED should blink twice. This is to signal that the main microprocessor is active, and ready to receive a command.

The LED provides important visual feedback to the status of the head; if the head has been activated and is being talked to by a controller, the LED is on solid, with some flickering. If the head is attached to the RS-485 line and hearing a command being sent to another head, it will flicker.

If the LED comes on solid, with no flickering at all, it usually means the RS-485 wiring is incorrect. Usually the ground and one of the data lines have been swapped. Check the wiring and try again.

## **USING THE PT-50 PAN TILT WITH PT-C-50 CONTROL PANEL**

The PT-C-50 control panel has bi-color LED's for status feedback of the current operation. Most of the individual functions for setup of the pan-tilt system have feedback that is shown by the LED display.

Note that the graphic overlay on the control panel has information in both black text below some of the buttons, and in red and green text below some of the buttons. The red text signifies the NORMAL number of the key; the green text shows the number of the key when the SHIFT key is pressed first. For example, to enter camera number 1, simply hit the 1 button when the LED is RED. To control camera 5, touch the SHIFT key, then the camera 1 button. The LED will turn green, signifying that camera 5 is selected.

Also note that the PT-C-50 is broken down into several different control zones. CAMERA NUMBER selection is at the top center, FUNCTIONS are in the middle center, and PRESET RECALL is located in the lower center. CAMERA FUNCTIONS, which allows you to control the HV-D30 camera functions remotely (if the optional PT-CCB50 camera control chip is installed in the pan tilt head) is located at the top right.

Below that are the ZOOM , FOCUS, and IRIS control buttons. Please note that not all lenses have remote iris level control; some lenses are auto iris only, and the IRIS buttons will not function in that case. Check the chart on page 7 to see what iris control your camera and lens model supports if you are not already aware.

The control joystick on the left hand side allows adjustment of the pan tilt head position. The pan tilt head is vector solving, i.e., it will move diagonally instead of just moving horizontally and vertically. It is also speed sensitive; deflect the joystick a small amount and the head moves slowly; deflect the joystick a large amount and the head moves quickly.

## **FUNCTION DEFINITIONS FOR PT-C-50 CONTROL PANEL**

### **CAMERA NUMBER**

Selects the camera / head combination to be moved. Select the CAMERA NUMBER button that corresponds to the pan tilt head you wish to control. For example, to control camera 1-4, press the 1-4 key. To select cameras 5-8, press SHIFT, then the 5-8 button you want. Note that the LED of the selected camera will change from RED to GREEN when cameras 5 to 8 are selected.

Select the ALL button if you wish to move ALL camera heads. Please note that for safety reasons when CAMERA ALL is selected, you may not clear travel limits. Travel limits must be cleared individually on a head by head basis.

### **SAVE FUNCTION**

This is used for saving preset pan tilt and lens positions. To save a preset, you must first be in the POSition mode. Press the POS button to enter POSition mode. Move the left joystick up, down, left, or right for positioning the head, manually aiming the shot the way you desire. Use the zoom and focus in/out buttons to select the field of view as desired. **YOU MUST ZOOM AND FOCUS TO SET UP YOUR SHOT AFTER ENTERING THE POSITION MODE !!**. (Fujinon and Canon telecon type servo lenses only. If using a C mount, DC drive lens, you don't need to enter POSition mode first. ) If you set up your zoom and focus before entering the POSITION mode, the lens will not report where it is in its' zoom and focus range to the software, and the lens preset will not be stored. Press the SAVE button followed by the PRESET button you wish to call it. For storing presets 11 thru 20, touch SAVE, SHIFT, and the PRESET button number. Note that the LED of the PRESET button will shift to GREEN to show that you are saving a number from 11 to 20. Up to 20 presets may be saved for each individual pan tilt head.

## **A.IRIS**

This button controls the toggling of Auto Iris being ON or OFF. When the LED is lit, AUTO IRIS is ON. This is only applicable for cameras and lens systems with auto iris functionality. Check the list on page 7 to see if your camera / lens has this feature.

## **FUNCTION**

Used in combination with the PRESET buttons to select special setup functions of the PT-50 system. Consult the detailed chart at the end of this manual for all of the FUNCTIONS available.

## **POS**

As described earlier with SAVE FUNCTION; this button puts the pan tilt head into POSition mode for saving presets.

## **LIMIT**

The LIMIT button in conjunction with the CAMERA FUNCTIONS keypad allows the operator to set the travel limits of the PT head. Limits are to prevent the head from traveling in areas not needed, or to prevent the camera / lens from hitting an obstruction. Limits on the Eagle™ pan tilt systems are set electronically, not mechanically. The PT-50 head uses DC stepper type motors instead of a geared motors. If an obstruction is encountered during travel, the motor merely slips until the condition is corrected. If this occurs, recalled preset positions will not be recalled correctly until the next time the PT-50 head passes through the “home” position of straight ahead and level.

The head is shipped with safety limits in place of about 30° each up and down, and 120° each left and right. It is recommended to stay with these limits until you are familiar with the operation of the system. Once familiar with the operation you may change the limits by touching the LIMIT button followed by the MENU button. This will clear all previously set limits.



Please note that if you clear the safety limits, and don't set new ones immediately, the head will revert to the previously set limits the next time power is cycled off and on. Simply clear the limits and set new ones right away to prevent this from happening.

Press LIMIT followed by the UP, DOWN, LEFT, and RIGHT buttons respectively to set the UP, DOWN, LEFT, and RIGHT limits. Note that you must move the head to those positions before setting the LIMIT, otherwise you will set all of the limits in one place, preventing the head from moving at all! If this happens, simply clear the limits and start over.

## **CHAIN**

Presets may be linked together for recall with this function. It will automatically recall presets at intervals of your choosing. First, recall the preset number you wish to start from; even if you are at this preset currently, you must recall it in order to use the CHAIN function. Press CHAIN and the number of the next preset; Press TIME and enter the wait time at this preset in seconds from 1 to 10. Repeat this process for as many presets as desired to be linked. Recall the first preset and the CHAIN will start. You may inter-

rupt the CHAIN function by moving the joystick up, down, left, or right.

## **AUTO WHITE**

The A.WHT button is a toggling function. Press the button by itself to execute the AUTO WHITE setting of the camera. Press SHIFT then A.WHT to execute the AUTO BLACK setting of the camera.

## **SPEED**

The SPEED button in combination with some other buttons allow various speed settings to be changed.

The PT-50 has three overall speed ranges; to change the range, press SPEED followed by PRESET 1, 2, or 3 for HIGH, MEDIUM, and SLOW speed ranges. The head is shipped in HIGH range.

To set the lens zoom speed, press SPEED, then the ZOOM down arrow button, followed by PRESET 1 through 10 (1 being the fastest, 10 being the slowest)

To set the lens focus speed, press SPEED, then the FOCUS down arrow button, followed by PRESET 1 through 10 (1 being the fastest, 10 being the slowest)

## **SHIFT**

The SHIFT button is used only as a modifier button in conjunction with other buttons to carry out special functions. It has no effect on it's own.

## **FUNCTION MODES**

Select the FUNCTION button then a PRESET button and the following combination of keys to run the shown function. Touch the FUNCTION key again to clear the function operation.

### **PRESET 1-- PRESET SPEED CHANGE**

This function allows changing preset speeds to different values than were originally chosen. For example, travel to preset 3 was originally set to speed 1(high range). If you now want to change travel speed to this preset to 2 (mid range), recall preset 3, then enter FUNCT, PRESET 1, then PRESET 1, 2 or 3 to change the preset to HIGH, MEDIUM, or LOW speed.

### **PRESET 2-- SCENE FILE ASSIGNMENT**

Dependent upon the camera being used, i.e., if using capable Hitachi cameras, SCENE files can be stored In the camera controller chip and recalled in conjunction with a specific location preset. This could be useful if the scene has multiple shots to be setup, under different lighting conditions. First, the scene files must be set up and stored using the camera functions / on screen menu

system of the camera. Next, decide which position preset you want to link to which scene file. For our example, let's use position preset 3, and link it to scene file 1. Recall preset 3 (by pressing the PRESET 3 button), then hit FUNCTION, PRESET 2, and PRESET 1, representing scene file 1. This will now link the position preset 3 and the scene file 1 together. In order to make any changes after saving this information, you must either resave or delete the position preset 1.

### **PRESET 3--INVERT DIRECTION**

This toggling FUNCTION will invert the left and right, and up and down directions of the PT-50 head. This is useful when the pan/tilt is to be ceiling mounted instead of tripod or wall mounted. It reverses the movement directions of the pan tilt head. This can be set individually on a head by head basis so that if a mix of upright and inverted heads are being used in the same room, they can be configured such that they all move the same direction.

Simply choose the camera number to change, followed by FUNCTION, and PRESET 3. Repeat the command sequence to change it back.

### **PRESET 4--ADDRESS OF PAN TILT HEAD**

The head address is set by the factory to 1 when shipped. If a change is required, simply enter FUNCTION, the PRESET 4 button, then PRESET 1 through 8 to readdress the head from number 1 through 8.

Note that the readdressing procedure will only work if you know the number the head is currently set to; if you don't know the number, first select CAMERA, ALL. This will allow you to talk to any head that is correctly wired up.



Note that this will set the number for all heads on the RS-485 comm line; you must disconnect the power or communication for all the heads except the one you wish to address, otherwise all the powered heads will be set to the same address!

### **PRESET 5--SET LENS TYPE.**

This is set by the factory when ordered for your specified lens type; 1 is for Rainbow and other CCTV type lenses, 2 is for Fujinon and Canon telecon lenses. The newer Fujinon C mount lenses with the -T11 designation are also set to type 2.

If you wish to change the lens type after receiving your PT head, press FUNCTION, PRESET 5, then PRESET 1 or 2 to set lens type 1 or 2. If you are changing lens types, you must also reconfigure the lens cable inside the PT-50 head. Contact Eagle™ tech support for assistance.

### **PRESET 6--HEAD STATUS CHECK**

This is a simple method of checking pan tilt head status remotely. Touch FUNCTION, then PRESET 6. If the head is working cor-

rectly, all of the PRESET LED's will flash green. If something is wrong with communications to the head, the LED's will flash RED. If there is no response from the head, the LED's will not flash at all.

## **CAMERA FUNCTIONS**

The buttons in the top right hand area of the PT-C-50 controller allow the adjustment of the on-screen camera setup menus of the HV-D30 and HV-D15/25 Hitachi cameras. To activate the on-screen menu, simply hit the MENU button. You may then scroll up and down through the menus of the cameras. To make a change to a setting, touch the left or right button. Push the MENU button again to turn off the MENU operation.

NOTE: To access the SPECIAL SET menu of the HV-D30 camera, press FUNCTION, then the MENU button. This is to access the SPECIAL SETUp menu screen. The SPECIAL SET menu of the HV-D15/25 is available by just pressing the MENU button, then pressing LEFT or RIGHT until the SPECIAL SET menu appears.

## **PAN-TILT OPERATIONS**



**Be sure to follow all of the installation and safety instructions included with the Eagle™ PT-50 pan tilt head before starting to use this system !!**

First, select the address of the head you wish to control. Since up to 31 Eagle™ heads may be on a single RS-485 line, you must choose the correct one to control (only 8 may be controlled from the PT-C-50 controller). Select CAMERA, then the number of the head to be controlled. Head addresses can be changed as described in the previous section about PRESET 4 for addressing.

If this is the first use of the system, the limits of pan tilt movement should be adjusted as desired now. Begin by entering LIMIT, MENU to clear all movement limits. This function will eliminate all safety limits that have been set at the factory to prevent excess travel. This clearing is temporary only; when power is cycled off and on, the previous limits will return unless you have set new limits. This will erase any limits previously set by the factory during testing.

Now, set the safety limits of travel as desired. Use the LIMIT then UP, DOWN, RIGHT, and LEFT for up, down, left, and right limit setting. Remember, that the pan tilt head has a range of pan of 360° (left or right 180°), and a tilt range of 90° (up or down 45°); it cannot turn more than a full circle. There are end travel stops programmed into the head at the factory to prevent traveling more than these amounts; these cannot be cleared when clearing the safety limits. Once the travel limits are set, normal usage of the pan tilt system may begin.

The PT-50 head uses DC stepper type motors instead of geared motors. If an obstruction is encountered during travel, the motor merely “slips” until the condition is corrected. This prevents damage to both the pan tilt head and the camera/lens. If this occurs,

recalled preset positions will not be recalled correctly until the next time the PT-50 head passes through the “home” position of straight ahead and level.

## **EAGLE™ PT-PS Series Pan Tilt Head—Power Supplies Installation and Operations Manual**

### **PRECAUTIONARY STATEMENT**

Improper settings and connections may cause damage to the PT-50 pan tilt, the camera, and the lens being used. Please read all of the following documentation before attempting the installation and configuration of these systems. If any of the instructions are unclear to you, call your servicing dealer or Hitachi before proceeding for clarification. Failure to correctly configure and install these systems may cause damage to the equipment, and will void the warranties. Please make sure before connecting or disconnecting any cables that the power supplies are turned OFF.

### **WARRANTY**

Hitachi Denshi America, Ltd. warrants to the original customer that each unit shall be free from malfunction due to defective workmanship or component failure for a period of ONE YEAR from the original date of delivery to the customer. For service under the warranty period, return authorization must be obtained before returning the product. This warranty does not apply to finish or appearance items, to malfunction due to abuse or operation in violation of published operating specifications, or to failures caused by improper connections, modifications, alterations, or other unauthorized repairs. This warranty does not cover labor costs for removal and/or reinstallation of equipment under warranty, nor does it include shipping costs. Under no circumstances shall Hitachi Denshi America, Ltd. or Display Devices, Inc., their owners or employees be liable to you for any special damages, including any lost profits, lost savings, or other incidental or consequential damages, or for any claim by any other party.

### **HARDWARE INSTALLATION**

Before starting installation, make certain that all power supplies to equipment are turned **OFF**.

### **POWER REQUIREMENTS AND PIN CONFIGURATIONS**

The PT-PS power supplies are designed to provide reliable power to the Eagle pan tilt heads. The PT-PS-1 will provide power for one PT-50 head and camera assembly; the PT-PS-2 will provide enough power for up to four PT-50 head and camera combinations and the PT-PS-3 provides 6.5 amps, for use with PT-200/300 heads and larger cameras. The Eagle™ pan tilt heads require 24 volts DC power. Maximum draw is approximately 2.5 amps; average current draw in operation is 1.5 amps. The camera power supply built into every PT head will provide power for camera / lens combinations drawing up to 3 amps at 12 VDC; if the camera / lens draws more than this, a separate external camera power supply is required. To help reduce power drop, it is common practice to run 4 conductors for power and tie two conductors together at the end entering the pantilt head, thus doubling the effective current carrying capability.

Here is a chart with recommended AWG for different distances ( at 77°F )

Distance in feet	AWG
20	28
50	26
100-1000	22
1000+	18

Here is the listing of pin configurations for the connector on the power supply output:

AMP 4 pin CPC connector

PIN 1 +24 VDC CAMERA POWER SUPPLY TO HEAD

PIN 2 +24 VDC CAMERA POWER SUPPLY TO HEAD

PIN 3 CAMERA POWER SUPPLY GROUND TO HEAD

PIN 4 CAMERA POWER SUPPLY GROUND TO HEAD



IMPORTANT NOTE: THE PT-PS-\* POWER SUPPLIES ARE AUTOSWITCHING FOR INPUT VOLTAGE RANGES BETWEEN 100 AND 240 VAC, 50 OR 60 HERTZ.

## FREQUENTLY ASKED QUESTIONS / SETUP PROBLEMS

### **My pan tilt head was working, but now has stopped responding. I still have a picture from the camera, but have no control. What happened?**

A: You are either trying to control the wrong head number, or the head has accidentally been readdressed to an unknown number, or the serial communications have failed. If you are certain that you are trying to control the correct head, follow this procedure to regain control.

1. On the PT-C-50 controller, select CAMERA, ALL. This will talk to any head on the line. Try to move the head up, down, left, or right. If it responds, then you have good communications. Follow the procedure on page 8 to readdress the head to the number you want it to be.
- 2) If it doesn't respond, then check the serial wiring path from the controller to the head(s). If you have multiple heads, and the other heads work correctly, then your wiring path is most likely correct, but should still be tested. Try moving the non-working head to a known working location and retesting.
- 3) The red LED on the side panel of the head is for troubleshooting and status. If a head is correctly wired and addressed, when you move the joystick, the LED will glow solid, with some modulation (flickering) seen as you move the joystick. If the LED comes on solid upon power up, then the RS-485 ground and one of the comm lines are reversed. Check your wiring again. If the LED never comes on solid, but only flickers, then either the head is hearing traffic for another head, or the RS-485 A & B comm lines are reversed. If you are certain the head is addressed properly, then swap the A&B comm lines and test again.

If it still doesn't work at a known good location, you have swapped the comm lines, and tried readdressing, then the head may be faulty. Contact Eagle tech support at (303) 412-0399 or [www.eaglepan tilt.com](http://www.eaglepan tilt.com).

### **My lens control isn't working correctly; the lens goes to one end of its' range and wont move.**

The lens type has been set incorrectly. The Eagle pan tilt system is capable of using either servo drive teleconferencing lenses, or DC drive C-mount lenses. If set to the wrong type, this symptom will result. Verify the type of lens you are using and check the lens type as shown on page 7.

### **I am trying to set up a preset shot, but the head isn't returning to the correct position or zoom/focus setting.**

This could be caused by a number of things. First, if using a teleconferencing lens, make sure you are going into POSITION mode (POS button) before trying to set the preset. If you are not in POSITION mode, the lens' zoom and focus settings cannot be memorized. Also, the pan and tilt joystick must be moved for the head's position settings to be recorded.

If the zoom and focus settings are retrieved correctly, but the head is landing high or low when recalling, then the weight balance of

the camera/lens assembly is probably off from front to rear. The assembly must be centered from front to rear to provide accurate recall; if it is balanced too far front, then it will probably be low in recalling presets above horizontal. If balanced too far rear, it will be high in recalling presets above horizontal. Remove the camera/lens assembly as needed in order to check the balance, and replace it in the correct position.

IF YOU ARE EXPERIENCING A PROBLEM NOT COVERED HERE, OR YOU HAVE TROUBLE UNDERSTANDING THESE SOLUTIONS, PLEASE CONTACT EAGLE TECH SUPPORT AT (303) 412-0399, M-F 8AM TO 5PM US MOUNTAIN TIME ZONE, OR EMAIL [shawn@displaydevices.com](mailto:shawn@displaydevices.com).

**PT-C-50 FUNCTIONS AS OF 10/04/02**

<b>Keystroke</b>	<b>Function</b>
<u>CAMERA 1-4</u>	Select Camera 1-4
<u>CAMERA All</u>	Select All Cameras
<u>SHIFT CAMERA 1-4</u>	Select Camera 5-8
<u>PRESET 1-10</u>	Recall head preset 1-10
<u>SHIFT PRESET 1-10</u>	Recall head preset 11-20
<u>SAVE PRESET 1-10</u>	Save head preset 1-10
<u>SAVE SHIFT PRESET 1-10</u>	Save head preset 11-20
<u>CHAIN PRESET1 TO 10</u>	Link one preset end to last preset
<u>CHAIN SHIFT PRESET1 TO 10</u>	Link one preset end to last preset
<u>TIME PRESET 1 TO 10</u>	Pause time between presets for last preset
AUTO IRIS	Toggle Auto Iris on/off
A.WHITE	Auto White function
SHIFT A.WHITE	Auto Black function
POS	Toggle Position/Speed Mode
<b>LIMIT UP</b> (camera func.)	Set up tilt limit
<b>LIMIT DOWN</b> (camera func.)	Set down tilt limit
<b>LIMIT LEFT</b> (camera func.)	Set left pan limit
<b>LIMIT RIGHT</b> (camera func.)	Set right pan limit
<b>LIMIT MENU</b> (camera func.)	Clear all movement limits
<b>SPEED PRESET1-3</b>	Set speed of pan/tilt
<b>SPEED ZOOM-DOWN PRESET1-10</b>	Set Zoom Speed
<b>SPEED FOCUS-DOWN PRESET1-10</b>	Set Focus Speed
<b>FUNCTION PRESET1 PRESET1-3</b>	Change speed of last preset 1-3
<b>FUNCTION PRESET2 PRESET1-4</b>	Assign camera scene to last preset 1-4
<b>FUNCTION PRESET3</b>	Invert up/down, left/right movement of PT head
<b>FUNCTION PRESET4 PRESET1-8</b>	Change head address to 1-8
<b>FUNCTION PRESET5 PRESET1-3</b>	Set lens type 1-3
<b>FUNCTION PRESET6</b>	Request status of current camera
<b>FUNCTION</b>	If in the middle of a multi-stroke function, this will cancel it
<b>MENU</b>	Camera Main Menu / Select
<b>FUNCTION MENU</b>	Camera Special Set Menu for HV-D30
<b>UP</b>	Camera Menu Up
<b>DOWN</b>	Camera Menu Down
<b>LEFT</b>	Camera Menu Left
<b>RIGHT</b>	Camera Menu Right
<b>ZOOM-UP</b>	Position of Zoom increase
<b>ZOOM-DOWN</b>	Position of Zoom decrease
<b>FOCUS-UP</b>	Position of Focus increase
<b>FOCUS-DOWN</b>	Position of Focus decrease
<b>IRIS-UP</b>	Iris increase
<b>IRIS-DOWN</b>	Iris decrease

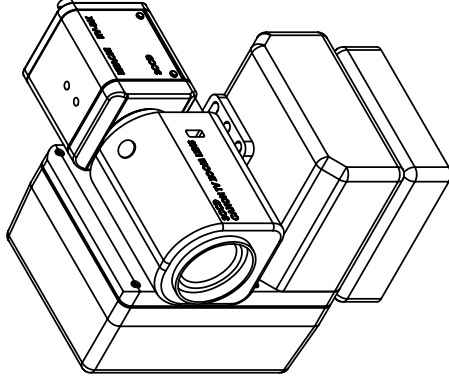
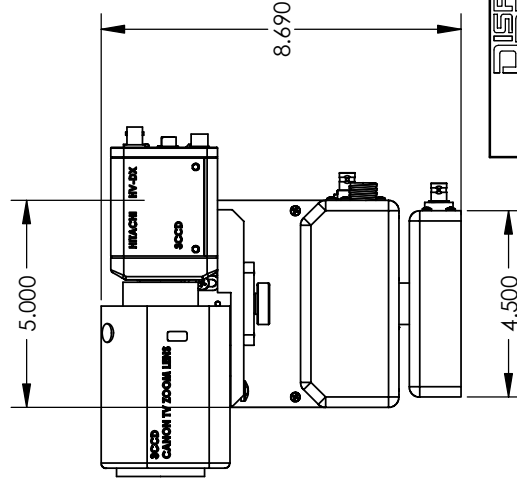
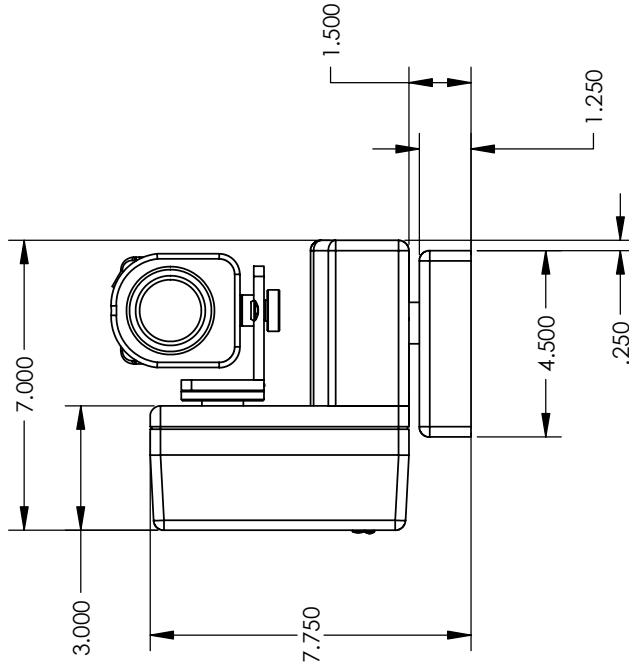
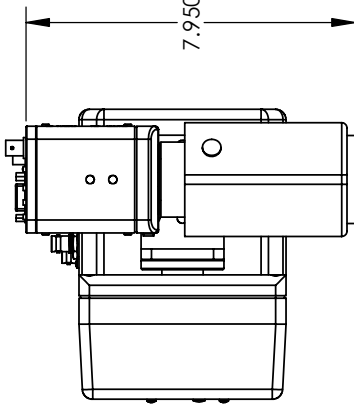

ISOMETRIC VIEW  
FOR REFERENCE ONLY

PT50 shown with Hitachi HVD30  
and Canon PH15x lens; other camera / lens  
combinations will have different dimensions.

**DISPLAY DEVICES, INC.**

THE INFORMATION CONTAINED  
HEREIN IS THE PROPERTY OF DISPLAY  
DEVICES, INC. ANY  
REPRODUCTION OR  
DISSEMINATION OF  
THIS INFORMATION WITHOUT THE  
WRITTEN PERMISSION OF  
DISPLAY DEVICES, INC. IS  
PROHIBITED.

TOLERANCES:  
.XX = ± .02  
.XXX = ± .010  
.XXXX = ± .0050  
ANGLE = ± 0.5

DRAWN	BAR	DATE	5/8/2002
CHECKED		SIZE	B
MATERIAL		DRAWING NO.	125-003
FINISH		REV	-

**DISPLAY DEVICES, INC**  
5880 SHERIDAN BLVD  
ARVADA, CO 80003

PT-50

125-003

125-003-SLDDRW

SHEET 2 OF 2

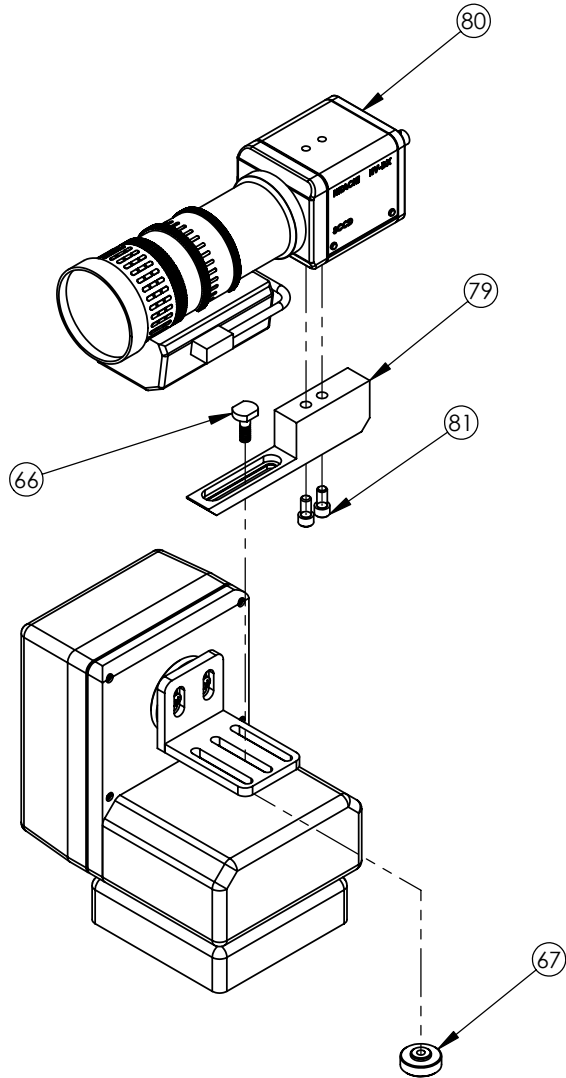

ITEM NO	QTY	PART NO	DESCRIPTION
62	1	125-035	ACCESS PANEL
66	1	125-044	CAMERA BRKT ADJ SCREW
67	1	125-045	ADJUSTER KNOB
79	1	125-060	PT50 ADT - HITACHI W/FUJINON
80	1		HITACHI CAMERA W/FUJINON LENS
81	2	5900-1975	1/4-20 X 1/2", SHCS, HX, GR8, BO

		<b>DISPLAY DEVICES, INC</b> 5880 SHERIDAN BLVD ARVADA, CO 80003	
THE INFORMATION CONTAINED IN THIS DRAWING IS THE PROPERTY OF DISPLAY DEVICES, INC. ANY REPRODUCTION IN PART OR WHOLE WITHOUT THE WRITTEN PERMISSION OF DISPLAY DEVICES, INC IS PROHIBITED		UNLESS OTHERWISE SPECIFIED DIMENSIONS ARE IN INCHES. <b>TOLERANCES:</b> .XX = ± .02 .XXX = ± .010 .XXXX = ± .0050 ANGLE = ± 0.5	
DRAWN: <b>BAR</b> DATE: <b>5/8/2002</b>		SIZE: <b>B</b>	DRAWING NO.: <b>125-003</b>
CHECKED: _____      DATE: _____		REV: <b>A</b>	
MATERIAL: <b>NONE</b>		SCALE: <b>NONE</b>	FILE NAME: <b>125-003.SLDDRW</b>
FINISH: <b>NONE</b>		SHEET 3 OF 3	
		<b>PT-50</b>	

17

HOOKUP CONTROLLER



18

HOOKUP MAIN POWER SUPPLY



# EAGLE

## PAN TILT SYSTEMS

Helping to bring your world into focus

### PT-50 QUICK START GUIDE

19

SET PT HEAD CONFIGURATION



20

APPLY POWER TO CONTROLLER FIRST, THEN TURN ON MAIN POWER SUPPLY FOR PT HEAD. WHEN POWERED UP, HEAD WILL MOVE TO HOME POSITION. LED ON SIDE OF HEAD WILL THEN GIVE TWO BLINKS.

21

SET PT HEAD ADDRESS BY CONFIGURATION SWITCHES ABOVE, OR BY USING PT-C-50 REMOTE CONTROL. CONSULT MANUAL FOR DETAILED DESCRIPTION.

22

RESET PT HEAD TRAVEL LIMITS IF NEEDED. SEE MANUAL FOR IMPORTANT DETAILS.

23

CHECK OPERATIONS OF PT-50 HEAD. HEAD SHOULD ALREADY BE FACTORY CONFIGURED FOR YOUR LENS TYPE. CONSULT MANUAL IF A CHANGE IS TO BE MADE TO INSURE CORRECT LENS OPERATION.

24

CHECK CAMERA REMOTE CONTROL FUNCTIONS (IF EQUIPPED WITH PT-CCB-50 REMOTE CONTROL OPTION).



Distributed by Hitachi Denshi America Ltd.  
150 Crossways Park Drive  
Woodbury, NY 11797  
(516)921-7200

Designed and Manufactured by  
Eagle Pan Tilt Systems  
5880 N Sheridan Blvd  
Arvada CO USA 80003

Document Version 1.0  
October 2002

For the latest info and updates go to <http://www.eaglepantilt.com>

1

UNPACK PT 50 HEAD  
AND VERIFY PACKAGE CONTENTS  
WITH LIST CONTAINED IN MANUAL

PLEASE READ INSTRUCTION  
MANUAL FULLY BEFORE  
STARTING INSTALLATION OF THE PT-50  
SYSTEM !!

2

CONFIGURE HV-D30 CAMERA  
FOR RS-232 OPERATIONS



3

MOUNT PT HEAD



4

BALANCE CAMERA  
AND LENS ON MOUNT



5

LOCKDOWN CAMERA



6

CAMERA POWER  
AND CONTROL  
CABLE



7

HOOKUP  
CAMERA CONTROL



8

HOOKUP  
CAMERA POWER



9

CAMERA POWER  
CONTROL OUT



10

HOOKUP AUTO IRIS  
CABLE (IF EQUIPPED)



11

CAMERA VIDEO  
OUT



12

VIDEO LOOP  
THROUGH



13

LENS CONTROL  
CABLE



14

COMPLETED  
WIRING



15

BUILD POWER  
CTRL INPUT



16

CONFIGURATION  
ACCESS PANEL



2

3