

Protocol of remote control software Ver.1.1

1. Comms* specifications

- Control system : Start-stop synchronization system
- Transmission rate : 9600 bps
- Data length : 8 bit
- Star bit : 1 bit
- Stop bit : 1 bit
- Parity : None
- Bit transfer : LSB first

*Comms: Communications

2. Comms control

The remote control software controls all communications. Data send/receive (BSC handshake) is by transferring TEXT data to the camera controller chip.

3. Comms procedure

The following pages indicate the camera controller chip and remote control software data protocol. In the description, the camera is designated as slave and the software as master.

- Receive protect timer (time out error)

The receive protect timer for master and slave processes is 1 second. For example, if 1 block of TEXT data is being received, if the data interval exceeds 1 second, error is produced and the data are lost. An acknowledgment of data receipt is not produced.

(1) Transmission from master (normal process)

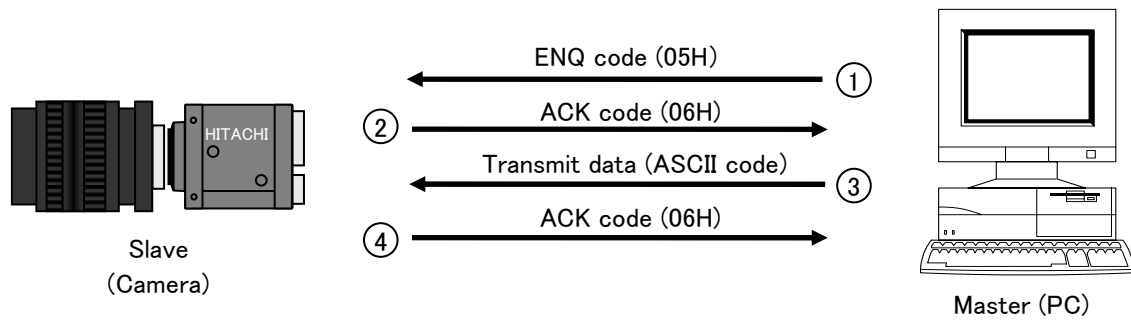

- ① Session starts when ENQ is sent from master to slave.
- ② Slave acknowledges by returning ACK to master.
- ③ Master sends data to slave.
- ④ Slave acknowledges receipt of data by again returning ACK to master and end the handshake.

(2) Master reads data (normal process)

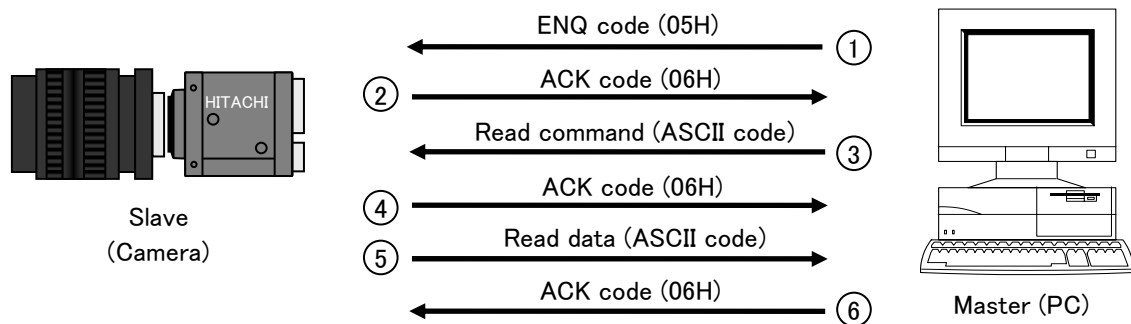

- ① Session starts when ENQ is sent from master to slave.
- ② Slave acknowledges by returning ACK to master.
- ③ Master sends read data command to slave.
- ④ Slave receives read data command, then acknowledges by returning ACK code to master.
- ⑤ Slave sends read data to master.
- ⑥ Master receives read data, then acknowledges by returning ACK code to slave.

(3) Data transmitted by master (control abort process)

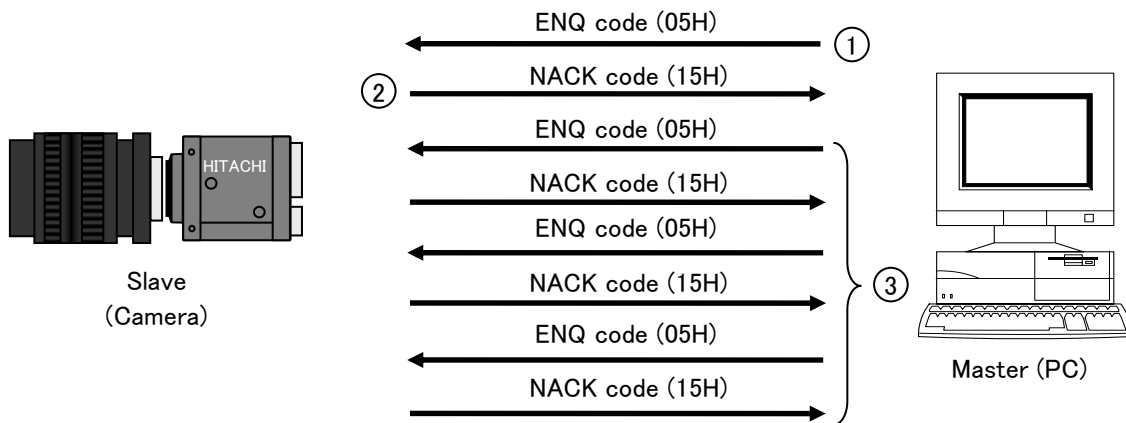

- ① Master sends ENQ code to slave.
- ② Since ACK code cannot be sent, slave sent NACK code to master.
- ③ Sequence is repeated 3 times in attempts to retransmit.

After receiving the 3rd successive NACK code, communications control is aborted

(4) Data transmitted by master (data error process)

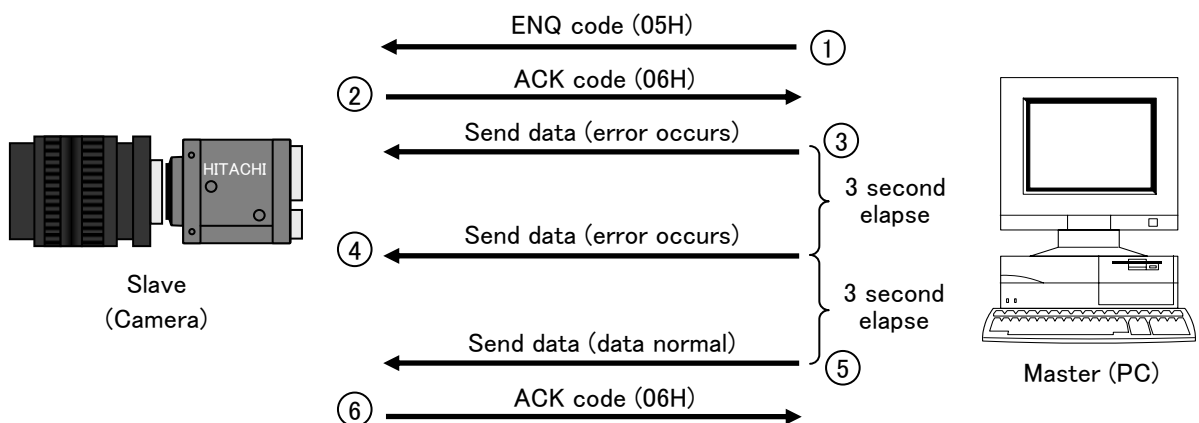

- ① Session starts when ENQ is sent from master to slave.
- ② Slave acknowledges by returning ACK to master.
- ③ Master sends data, but error detected (framing, over-run error).
- ④ Slave detects error and does not accept data.
- ⑤ Sequence 3 and 4 repeats, then master transfers normal data.
- ⑥ Slave detects normal data and returns ACK code to master to end the session.

(6) Transmission frame error (Master receive)

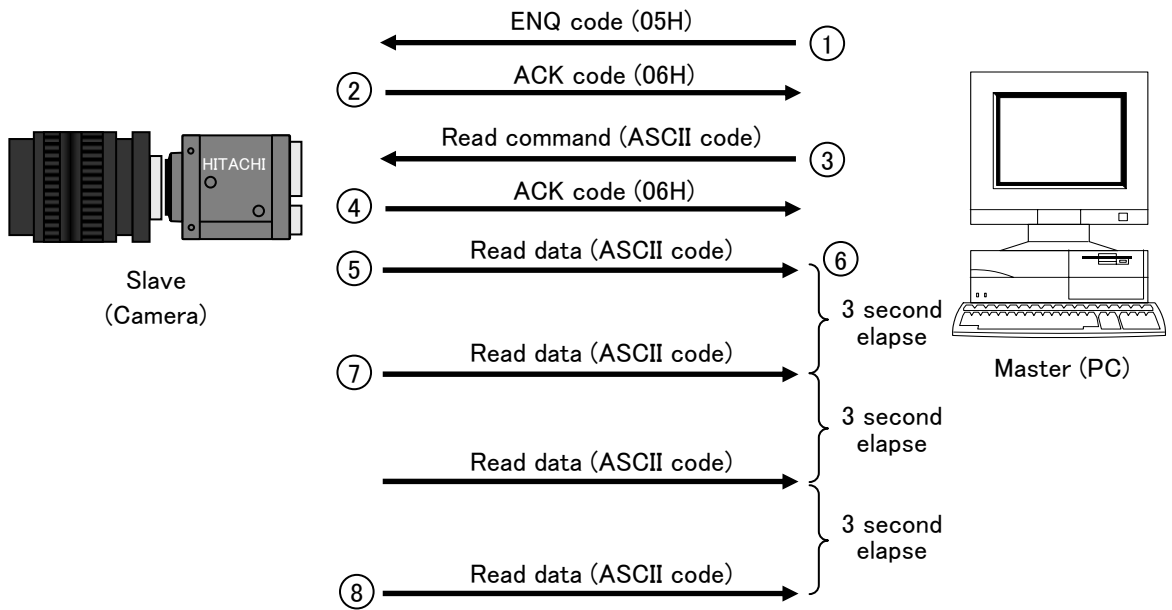

- ① Session starts when ENQ is sent from master to slave.
- ② Slave acknowledges by returning ACK to master.
- ③ Master sends read command.
- ④ Slave returns ACK code to acknowledge read command.
- ⑤ Slave sends corresponding read data to master.
- ⑥ For some reason, master fails to receive read data.
- ⑦ Slave fails to receive acknowledgment of read data and attempts to resend every 3 seconds for 3 times.
- ⑧ After the third failure, slave aborts the sequence and ends communication.

4. Comms command Text data format

- (1) Send data and read command data (master to slave)
- (a) Command data are converted into ASCII code and transmitted.
- (b) Comms byte quantity is 18.
- (c) Comms data format (transmission sequence).



- STX (start code) : Code indicating start of text.
1 byte (02H)
- Text data : Transmit / receive data.
14 byte (ASCII code)
- ETX (end code) : Code indicating end of text.
1 byte (03H)
- SUM : XOR result (FFH), of adding STX, Text data, and ETX.
2 byte (ASCII code)

(d) Text data format details (transmission sequence).

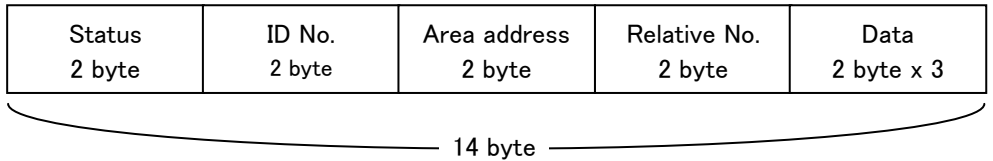

- Status : Transmission data status.
2 byte (ASCII code)
Used for EEPROM write (0: write absent, 1: write present).
- ID No. : Camera peculiar ID.
KP-F500PCL/SCL has (FFH).
2 byte (ASCII code)
- Area address : Sets number (0 to 255) for each adjustment item.
2 byte (ASCII code)
- Relative No. : Sets number determined by each area address.
2 byte (ASCII code)
- Data (note) : Sets data to be transmitted.
2 byte x 3 (ASCII code)

(2) Read (receive) data (slave to master)

(a) Command data are converted into ASCII code and transmitted.

(b) Comms byte quantity is 10.

(c) Comms data format (transmission sequence)

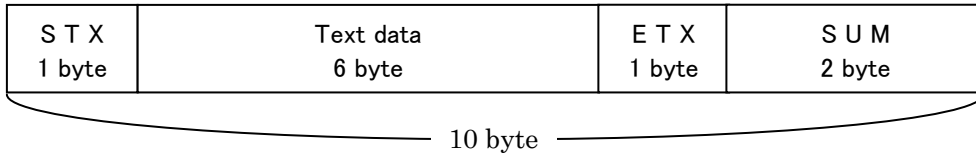

- STX (start code) : Code indicating start of text.
1 byte (02H)
- Text data : Transmit / receive data.
6 byte (ASCII code)
- ETX (end code) : Code indicating end of text.
1 byte (03H)
- SUM : XOR result (FFH), of adding STX, Text data, and ETX.
2 byte (ASCII code)

(d) Text data details (transmission sequence)

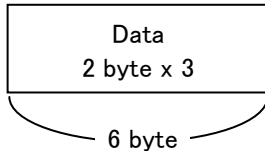

- Data (note) : Sets data to be transmitted.
2 byte x 3 (ASCII code)

Note: Data transfer sequence

Area address	Data type	Data bytes	1st byte	2nd byte	3rd byte
0x01, 0x81	Common data	1	Data	0x00	0x00
		2	Upper	Lower	0x00
		3	Upper	Mid	Lower

5. Calculation method of checksum

Example

STX	1	2	3	4	5	6	7	ETX	SUM
	STATUS	ID NO	AREA ADDRESS	RELATIVE NO	DATA				
02	01	FF	01	04	00	00	00	03	28

1. STATUS to DATA are transformed into hexadecimal number on the basis of the ASCII code.

'0'→(30)₁₆ '1'→(31)₁₆ '4'→(34)₁₆ 'F'→(46)₁₆ STX: (02)₁₆ ETX: (03)₁₆

2. STX to ETX are added all.

$$(02)_{16} + (30)_{16} + (31)_{16} + (46)_{16} + (46)_{16} + (30)_{16} + (31)_{16} + (30)_{16} + (34)_{16} + (30)_{16} + (30)_{16} + (30)_{16} + (30)_{16} + (30)_{16} + (03)_{16} = (2D7)_{16}$$

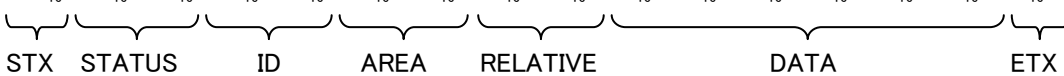

3. The XOR (Exclusive OR) between the value obtained in 2 clause and (FF)₁₆ are taken, then two column under the answer become SUM

(2D7)₁₆ XOR (FF)₁₆ = (228)₁₆

6. Setting command data (Note: 1 to 7 and SUM need to be transformed into ASCII code)

Item		STX	1	2	3	4	5	6	7	ETX	SUM	
			STATUS	ID NO.	AREA ADDRESS	RELATIVE NO.	DATA					
TRIGGER	MODE	OFF	02	01	FF	01	04	00	00	00	03	28
		FIXED	02	01	FF	01	04	01	00	00	03	27
		1TRIG	02	01	FF	01	04	02	00	00	03	26
		RESET CONT (*1)	02	01	FF	01	04	03	00	00	03	25
		VD CONT (*1)	02	01	FF	01	04	04	00	00	03	24
	POLARITY (TRIG-A)	POSITIVE	02	01	FF	01	0F	00	00	00	03	16
		NEGATIVE	02	01	FF	01	0F	01	00	00	03	15
	POLARITY (TRIG-B)	POSITIVE (*1)	02	01	FF	01	10	00	00	00	03	2B
		NEGATIVE (*1)	02	01	FF	01	10	01	00	00	03	2A
	HD RESET	NON-RESET (*1)	02	01	FF	01	02	00	00	00	03	2A
RESET (*1)		02	01	FF	01	02	01	00	00	03	29	
SHUTTER SPEED	PRESET (*1)	OFF	02	01	FF	01	08	00	00	00	03	24
		PRESET1	02	01	FF	01	08	01	00	00	03	23
		PRESET2	02	01	FF	01	08	02	00	00	03	22
		PRESET3	02	01	FF	01	08	03	00	00	03	21
		PRESET4	02	01	FF	01	08	04	00	00	03	20
		PRESET5	02	01	FF	01	08	05	00	00	03	1F
		PRESET6	02	01	FF	01	08	06	00	00	03	1E
		PRESET7	02	01	FF	01	08	07	00	00	03	1D
		PRESET8	02	01	FF	01	08	08	00	00	03	1C
	VARIABLE	02	01	FF	01	08	FF	00	00	03	F8	
VARIABLE VALUE (*1) (2Byte)	MIN(1/100000(s))	02	01	FF	01	11	00	00	00	03	2A	
	MAX(1/61.24s)	02	01	FF	01	11	03	12	00	03	24	
DATA BIT	8bit	02	01	FF	01	14	00	00	00	03	27	
	10bit	02	01	FF	01	14	01	00	00	03	26	
VD/FVAL	VD	02	01	FF	01	15	00	00	00	03	26	
	FVAL	02	01	FF	01	15	01	00	00	03	25	
HD/LVAL	HD	02	01	FF	01	16	00	00	00	03	25	
	LVAL	02	01	FF	01	16	01	00	00	03	24	
GAIN(2Byte)(*1)	MIN(0)	02	01	FF	01	0C	00	00	00	03	19	
	MAX(462)	02	01	FF	01	0C	01	CE	00	03	F0	
BLACK LEVEL(*1)	MIN(0)	02	01	FF	01	17	00	00	00	03	24	
	MAX(31)	02	01	FF	01	17	1F	00	00	03	0D	
PARTIAL SCAN (*1)	MODE	OFF	02	01	FF	01	1E	00	00	00	03	16
		ON	02	01	FF	01	1E	01	00	00	03	15
	START (2Byte)	MIN(1)	02	01	FF	01	1F	01	00	00	03	14
		MAX(494)	02	01	FF	01	1F	01	EE	00	03	EA
	WIDTH (2Byte)	MIN(1)	02	01	FF	01	20	01	00	00	03	29
MAX(494)		02	01	FF	01	20	01	EE	00	03	FE	
VERTICAL 2 PIXEL ADDITION (*1)	OFF	02	01	FF	01	13	00	00	00	03	28	
	ON	02	01	FF	01	13	01	00	00	03	27	
USER AREA (2Byte) (*2)		——	02	01	FF	10	16 to 7F	XX	XX	00	03	XX

(*1) It is different by a model. Please refer to a comparison table of each model. MAX value is in case of KP-F30PCL/SCL.

(*2) KP-F30SCL, KP-F80SCL and KP-F200SCL do not have the function.

The comparison table of each model

Function		KP-F30PCL/SCL	KP-F80PCL/SCL	KP-F200PCL/SCL	KP-FB30PCL/SCL	KP-F31PCL/SCL	KP-F230PCL/SCL
TRIGGER	RESET CONT	Yes	Yes	None	None	None	None
	VD CONT	Yes	Yes	Yes	None	None	None
	POLARITY (TRIG-B)	Yes	Yes	Yes	None	None	None
	HD-RESET	Yes	Yes	Yes	Always RESET	Always RESET	Always RESET
SHUTTER SPEED	PRESET1	1/60s	1/36s	1/15s	1/60s	1/120s	1/30s
	PRESET2	1/250s	1/60s	1/60s	1/250s	1/250s	1/60s
	PRESET3	1/500s	1/125s	1/125s	1/500s	1/500s	1/125s
	PRESET4	1/1000s	1/250s	1/250s	1/1000s	1/1000s	1/250s
	PRESET5	1/2000s	1/1000s	1/1000s	1/2000s	1/2000s	1/1000s
	PRESET6	1/4000s	1/2000s	1/2000s	1/4000s	1/4000s	1/2000s
	PRESET7	1/10000s	1/10000s	1/10000s	1/10000s	1/10000s	1/10000s
	PRESET8	1/50000s	1/50000s	1/50000s	1/50000s	1/50000s	1/50000s
	VARIABLE	1/100000 to 1/61.24s (0x0000 to 0x0312)	1/100000 to 1/36.26s (0x0000 to 0x0332)	1/100000 to 1/15.01s (0x0000 to 0x03A1)	1/100000 to 1/61.24s (0x0000 to 0x0312)	1/100000 to 1/120.3s (0x0000 to 0x02D0)	1/100000 to 1/30.12s (0x0000 to 0x0342)
GAIN	0 to 18.48dB (0 to 462) 0.04dB step	0 to 18.48dB (0 to 462) 0.04dB step	0 to 18.48dB (0 to 462) 0.04dB step	0 to 12dB (0 to 300) 0.04dB step	0 to 12.02dB (0 to 336) 0.0358dB step	0 to 12.02dB (0 to 336) 0.0358dB step	
BLACK LEVEL	14/1024 to 76/1024 (0 to 31) 2LSB step	14/1024 to 76/1024 (0 to 31) 2LSB step	14/1024 to 76/1024 (0 to 31) 2LSB step	0/1024 to 128/1024 (0 to 32) 4LSB step	0/1024 to 128/1024 (0 to 32) 4LSB step	0/1024 to 128/1024 (0 to 32) 4LSB step	
PARTIAL SCAN	START: 1 to 494 WIDTH: 1 to 494 START+WIDTH ≤ 495	START: 1 to 768 WIDTH: 1 to 768 START+WIDTH ≤ 769	START: 1 to 1236 WIDTH: 1 to 1236 START+WIDTH ≤ 1237	START: 1 to 494 WIDTH: 1 to 494 START+WIDTH ≤ 495	START: 1 to 494 WIDTH: 1 to 494 START+WIDTH ≤ 495	START: 1 to 1236 WIDTH: 1 to 1236 START+WIDTH ≤ 1237	
VERTICAL 2 PIXEL ADDITION	None	None	None	Yes	Yes	Yes	

7. Read-out command data (Note: 1 to 7 and SUM need to be transformed into ASCII code)

Item		STX	1	2	3	4	5	6	7	ETX	SUM
			STATUS	ID NO.	AREA ADDRESS	RELATIVE NO.	DATA				
TRIGGER	MODE	02	00	FF	81	04	00	00	00	03	21
	POLARITY(TRIG-A)	02	00	FF	81	0F	00	00	00	03	10
	POLARITY(TRIG-B)	02	00	FF	81	10	00	00	00	03	24
	HD RESET	02	00	FF	81	02	00	00	00	03	23
SHUTTER SPEED	PRESET	02	00	FF	81	08	00	00	00	03	1D
	VARIABLEVALUE (2Byte)	02	00	FF	81	11	00	00	00	03	23
DATA BIT		02	00	FF	81	14	00	00	00	03	20
VD/FVAL		02	00	FF	81	15	00	00	00	03	1F
HD/LVAL		02	00	FF	81	16	00	00	00	03	1E
GAIN (2Byte)		02	00	FF	81	0C	00	00	00	03	12
BLACK LEVEL		02	00	FF	81	17	00	00	00	03	1D
PARTIAL SCAN	MODE	02	00	FF	81	1E	00	00	00	03	0F
	START (2Byte)	02	00	FF	81	1F	00	00	00	03	0E
	WIDTH (2Byte)	02	00	FF	81	20	00	00	00	03	23
VERTICAL 2 PIXEL ADDITION		02	00	FF	81	13	00	00	00	03	21
VENDOR NAME (2Byte) (*1)		02	00	FF	90	00 to 07	00	00	00	03	XX
MODEL NAME (2Byte) (*1)		02	00	FF	90	08 to 0F	00	00	00	03	XX
SERIAL NO. (2Byte) (*1)		02	00	FF	90	10 to 13	00	00	00	03	XX
CAMERA VERSION (2Byte) (*1)		02	00	FF	90	14 to 15	00	00	00	03	XX
USER AREA (2Byte) (*1)		02	00	FF	90	16 to 7F	00	00	00	03	XX

(*1) KP-F30SCL, KP-F80SCL and KP-F200SCL do not have the function.

The return format from the camera is based on 4. (2)