



Instruction Manual

1T-SX-524
4x1 DVI Switcher

Table of Contents

1.0	Introduction	2
2.0	Specifications	3
3.0	Checking Package Contents	3
4.0	Connecting The Hardware	4
5.0	Operating The Unit	4
6.0	Troubleshooting	5
7.0	Limited Warranty	6
8.0	Regulatory Compliance	6
9.0	Contact Information	7

1.0 INTRODUCTION

Thanks for purchasing this 1T-SX-524 4x1 DVI Switcher from TV One. The DVI Switcher is designed to allow the switching of four DVI (HDCP or non-HDCP compliant) DVI signals to one DVI display device. Our professional video conversion products have been serving the industry for over twenty years. TV One offers a full line of high quality Seamless Switchers, Video Scalers, Up/Down/Cross Converters, Analog-Digital Converters (SD/HD-SDI, HDMI, DVI), Format Converters, Standards Converters, TBC/Frame Synchronizers, Matrix Routing Switchers, Signal Distribution Amplifiers and Cat.5 Transmission Systems.

1.1 Liability Statement

Every effort has been made to ensure that this product is free of errors. TV One cannot be held liable for the use of this hardware or any direct or indirect consequential damages arising from its use. It is the responsibility of the user of the hardware to check that it is suitable for his/her requirements and that it is installed correctly. All rights reserved. No parts of this manual may be reproduced or transmitted by any form or means electronic or mechanical, including photocopying, recording or by any information storage or retrieval system without the written consent of the publisher.

TV One reserves the right to revise any of its hardware and software following its policy to modify and/or improve its products where necessary or desirable. This statement does not affect the legal rights of the user in any way.

All third party trademarks and copyrights are recognised. The TV One logo, TV One-task and CORIO are the registered Trademarks of TV One. All other trademarks are the property of their respective holders.

1.2 Features

The 1T-SX-524 4x1 DVI Switcher has many features that enable it to perform in a superior manner. Among those features you will find:

- Supports HDCP
- Supports DDWG standard resolution
- 4x DVI Sources share one DVI display or other device
- Control via push buttons or IR Remote (included)

2.0 SPECIFICATIONS

Performance	
Maximum Pixel Rate	165MHz
Maximum Resolution	1920 X 1200@60Hz
I/O Connectors	
DVI-D Source Port Connectors	4x DVI-I 29 pin female
Display Device Port Connector	1x DVI-I 29 pin female
Display device selection	Push Button or Remote
Mechanical	
Dimension (H-W-D)	44x160x70mm (1.7"x6.3"x2.8")
Weight	400 g (0.86 lbs)
Warranty	
Limited Warranty	2 Years Parts and Labor
Environmental	
Operating Temperature	0° to +40°C (+32° to +104° F)
Operating Humidity	10% to 85%, Non-condensing
Storage Temperature	-20° to +60°C (-4° to +140° F)
Storage Humidity	10% to 85%, Non-condensing
Power Requirements	
External Power Supply	5VDC@2A
Regulatory Approvals	
Switcher Unit	FCC, CE, RoHS
Power Supplies	UL, CUL, CE, PSE, GS, RoHS
Accessories Included	
1x Power Adapter	US, UK or Euro
1x Remote Control	
1x Operations Manual	
Optional Accessories	
Remote IR Sensor	1T-IRR-100 with 5' Cable

3.0 CHECKING PACKAGE CONTENTS

Before attempting to use this unit, please check the packaging and make certain the following items are contained in the shipping carton:

- 1x 1T-SX-524 DVI Switcher w/Remote Control
- 1x 5 VDC AC Adapter
- 1x Operations Manual

Note: Please retain the original packing material should the need ever arise to return the unit. If you find any items are missing, contact your reseller or TV One immediately. Have the Model and Serial Number and Invoice available for reference when you call.

4.0 CONNECTING THE HARDWARE

Please study the panel drawings below and become familiar with the signal inputs, output, power requirements/inputs plus any controls present. This will facilitate in better understanding the operating instructions that follow. After familiarizing yourself with the unit's controls and connectors, connect appropriate input and output cables plus the AC adapter as explained below.

Note: If you have purchased the optional IR remote control extender, operate the unit without the extender installed at first and then, after determining that the unit is operating properly, plug in the extender and verify the unit functions appropriately with that unit.

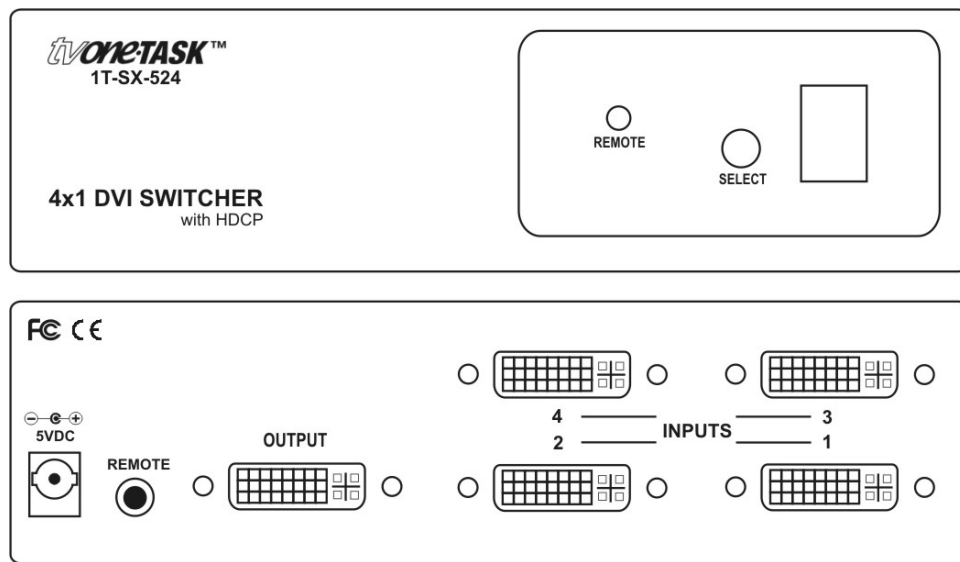

5.0 OPERATING THE UNIT

Before installation, please make sure all of devices have been turned off.

- Connect your DVI display to the switcher's DVI output using high quality cable
- Connect up to 4x DVI-D sources to the switcher's inputs using high quality cables
- Plug the 5VDC power adapter into the rear of the unit
- Plug the Power Adapter into a working AC socket
- Power on all input and output devices
- Select the DVI source you want to view as explained below

You can select the channels you want to access in two ways: front panel push button selection or via the remote control included with the package content.

5.1 Front Panel Push Button Selection:

The front panel push button is used to select the channel to be displayed on the screen. Pressing the button during normal operation will cause the next channel to be selected in sequence.

5.2 Remote Control Selection:

The channel selection can also be made via the provided remote by pressing the appropriate button.

Note: If you have a problem with the IR control conflicting with other devices, the remote allows users to reconfigure four (A, B, C, D) alternate combinations of IR codes.

The default code is A.

Push and hold the IR code button (A, B, C or D) on remote control panel for 2 seconds. The 7-segment LED display will show the IR code for one second when the new IR code is set.

Note – The optional 1T-IRR-100 Remote IR Extender allows the Switcher to be placed in a concealed location and still use the IR Remote Control. The IR Extender comes with a 5' cable with 3.5mm Mini connectors, but longer lengths can be used.

6.0 TROUBLESHOOTING

If the switcher does not appear to be functioning, make certain that all the DVI sources and the DVI capable monitor are functioning correctly by connecting each DVI source in turn directly to the monitor using a cable with a length of 6 feet or less. If the signal is present under those conditions, make certain that the power is present on the switcher. If it is, measure the cable length you are attempting to use between the sources to the switcher and the switcher to the monitor. The cables must be 6 foot long or less. Lastly, inspect the cables and connectors for damage. *Note: If you need to span a distance of greater than 6 feet, purchase TV One's 1T-DVI-RH repeater which will allow you to extend a cable run up to 40 feet.*

After trying the above suggestions should the problem still persist, contact your dealer for additional suggestions before contacting TV One. Should the dealer's technical personnel be unable to assist you, contact TV One via our support website:

<http://tvone.crmdesk.com>. Create a technical support request on the site and our support team will respond within a short period of time.

7.0 LIMITED WARRANTY

LIMITED WARRANTY – With the exceptions noted in the next paragraph, TV One warrants the original purchaser that the equipment it manufactures or sells will be free from defects in materials and workmanship for a period of two years from the date of purchase. Should this product, in TV One’s opinion, prove defective within this warranty period, TV One, at its option, will repair or replace this product without charge. Any defective parts replaced become the property of TV One. This warranty does not apply to those products which have been damaged due to accident, unauthorized alterations, improper repair, modifications, inadequate maintenance and care, or use in any manner for which the product was not originally intended.

Items integrated into TV One products that are made by other manufacturers, notably computer hard drives and liquid crystal display panels, are limited to the term of the warranty offered by the respective manufacturers. Such specific warranties are available upon request to TV One.

If repairs are necessary under this warranty policy, the original purchaser must obtain a Return Authorization Number from TV One and return the product to a location designated by TV One, freight prepaid. After repairs are complete, the product will be returned, freight prepaid.

LIMITATIONS - All products sold are "as is" and the above Limited Warranty is in lieu of all other warranties for this product, expressed or implied, and is strictly limited to two years from the date of purchase. TV One assumes no liability to distributors, resellers or end-users or any third parties for any loss of use, revenue or profit.

TV One makes no other representation of warranty as to fitness for the purpose or merchantability or otherwise in respect of any of the products sold. The liability of TV One with respect to any defective products will be limited to the repair or replacement of such products. In no event shall TV One be responsible or liable for any damage arising from the use of such defective products whether such damages be direct, indirect, consequential or otherwise, and whether such damages are incurred by the reseller, end-user or any third party.

8.0 REGULATORY COMPLIANCE

The 1T-SX-524 has been tested for compliance with appropriate FCC and CE rules and regulations. The Power Adaptor/Supply has been tested for compliance with appropriate UL, CUL, CE, PSE, GS Rules, Regulations and/or Guidelines. This Product and Power Adapter is RoHS Compliant.

9.0 CONTACT INFORMATION

Should you have questions or require assistance with this product in areas not covered by this manual, please contact TV One at the appropriate location.

TV One USA

2791 Circleport Drive
Erlanger, KY 41018
USA
Tel 859-282-7303
Fax 859-282-8225
sales@tvone.com
www.tvone.com

TV One Europe

Continental Approach
Westwood Industrial Estate
Margate, Kent CT9 4JG, UK
Tel +44 (0)1843 873311
Fax +44 (0)1843 873312
sales.europe@tvone.com
www.tvone.eu

TV One Latin America

6991 NW 82 Avenue #8
Miami, FL 33166
USA
Tel 305-396-6275
Fax 305-418-9306
sales.latinoamerica@tvone.com
www.tvonela.com

TV One Mercosur

Honduras 5849, 2nd Floor, Office C
(C1414BNI) Capital Federal
Buenos Aires, Argentina
Tel +54 11 4771-5570
Fax +54 11 4771-5570
sales.latinoamerica@tvone.com
www.tvonela.com

TV One Asia

11F, NO.28, Sec. 2
San-Min Rd, Panchiao City
Taipei Hsien 220
Taiwan R.O.C.
Tel +886 2 8951-0674
Fax +886 2 8951-0675
sales.asia@tvone.com
www.tvoneasia.com

TV One China

Rm.9C, Neiwailian Building
No.518 Shangcheng Road
Pudong, Shanghai
China 200120
Tel +86 21 5830-2960
Fax +86 21 5878-0161
Email: sales.china@tvone.com
Website: www.tvonechina.com

End of Manual